



MODEL 23
VIBRATORY
DRIVER/EXTRACTOR

OPERATING AND MAINTENANCE MANUAL

J&M MODEL 23

VIBRATORY PILE DRIVER/EXTRACTOR

WICK INSERTER

WITH MODEL 51 POWER PACK

OM-23/51-0309



**J&M FOUNDATION
EQUIPMENT, LLC**

SPECIALIZING IN PILE DRIVING EQUIPMENT



**MODEL 23
VIBRATORY
DRIVER/EXTRACTOR**



**MODEL 23
VIBRATORY
DRIVER/EXTRACTOR**

J&M MODEL 23
VIBRATORY PILE DRIVER/EXTRACTOR
WITH MODEL 580 POWER UNIT
OM-23/51-0309

PREFACE

INFORMATION This manual was prepared to acquaint the owner, operator and serviceman with the operation and maintenance of the vibratory driver/extractor. We strongly suggest that this manual be carefully studied before operating or undertaking any maintenance work on the unit. It is not meant to be all inclusive as to content, and any questions and/or doubt should be directed to J&M before proceeding with any operation or maintenance.

This manual is organized into two major categories.

The first category is for OPERATING INSTRUCTIONS of the unit and includes a GENERAL DESCRIPTION section, which presents a basic explanation of the driver/extractor specifications. The MAINTENANCE AND ADJUSTMENT section should be referred to for all servicing of equipment. All machines and equipment require systematic, periodic inspection and maintenance, if they are to perform satisfactorily.

The second category is for parts ordering and it includes both a PARTS LIST and a pictorial drawing of the assembly. Refer to the ORDERING PARTS section of the PARTS LIST for more specific procedures regarding parts ordering. Adherence of the listed procedures will insure receipt of the required part(s) with the minimal amount of delay or error.

Manual release date: 3-26-2009

J&M reserves the right to update or revise this manual as required, check with J&M for current release date.



**MODEL 23
VIBRATORY
DRIVER/EXTRACTOR**



**MODEL 23
VIBRATORY
DRIVER/EXTRACTOR**

Warranty

American Piledriving Equipment, Inc. J&M Foundation Equipment LLC
STANDARD WARRANTY

American Piledriving Equipment, Inc./J&M Foundation Equipment LLC (APE/J&M) warrants new products sold by it to be free from defects in material or workmanship for a period of one year after the date of delivery to the first user and subject to the following conditions:

APE/J&M's obligation and liability under this WARRANTY is expressly limited to repairing or replacing at APE/J&M's option, any parts which appear to APE/J&M upon inspection to have been defective in material or

workmanship. Such parts shall be provided at no cost to the user, at the business establishment of APE/J&M or the authorized APE/J&M distributor of the product during regular working hours. This WARRANTY, shall not apply to component parts or accessories of products not manufactured by APE/J&M and which carry the warranty of the manufacturer thereof, or to normal maintenance (scraped and scived lube and fuel lines, worn cushion material in the drive base) or normal maintenance parts (such as fouled injectors, weakened check valve springs, damaged grease zirts caused by use over time).

Replacement or repair parts installed in the product covered by this WARRANTY are warranted only for the remainder of the warranty as if such parts were original components of said product. APE/J&M makes no other warranty, expressed or implied and makes no warranty of merchantability of fitness for any particular purpose.

APE's obligation under this WARRANTY shall not include any transportation charges, costs of installation, duty, taxes or any other charges whatsoever, or any liability for direct, indirect, incidental or consequential damage or delay. If requested by APE/J&M, products or parts for which a warranty claim is made are to be returned transportation prepaid to APE/J&M. Any improper use, including operation after discovery of defective or worn parts, operation beyond rated capacity, substitution of any parts whatsoever, or parts not approved by APE/J&M or any alteration or repair by others in such manner as in APE/J&M's judgment affects the product materially and adversely, shall void this warranty.

**ANY TYPE OF WELDING ON EQUIPMENT
WILL VOID THE WARRANTY**

Refusal: Vibros: If the pile does not move one foot in 30 seconds of vibro operation at full speed. Resort to a larger vibro. APE/J&M equipment may exceed the refusal driving criteria for short periods of time as may be needed to penetrate hard soil layers or obstacles. In such cases, a heat gun is used to monitor the temperature of the bearings and related components to prevent use of the machine beyond 210 degrees. Contact APE/J&M or your local APE/J&M distributor for special instructions when faced with refusal conditions.

Refusal: Diesels: Do not exceed 10 blows per inch or 120 blows per foot. In cases of setting of the pile it is permitted to increase the blow count to 250 blows per foot, but only for one foot of driving penetration. Pile inspectors should consult the APE factory for permission to exceed these limits. Failure to do so will void the warranty. This standard specification is accepted by the DFI (Deep Foundations Institute) and the PDCA (Pile Contractors Association) and by all manufacturers of pile driving equipment.



**MODEL 23
VIBRATORY
DRIVER/EXTRACTOR**

TABLE OF CONTENTS

I.	<u>GENERAL DESCRIPTION</u>	<u>PAGE</u>
	A. General	I- 1
	B. Vibrator	I- 2
	C. Hydraulic Clamp	I- 2
	D. Power Unit	I- 2
	E. Hoses	I- 2
	F. Remote-Control Pendant	I- 3
	G. Specifications	I- 3
II.	<u>PREPARATION FOR OPERATING</u>	
	A. General	II- 1
	B. Safety Precautions	II- 1
	C. Rigging of Vibrator	II- 5
	D. Connection of Hydraulic Clamp	II- 5
	E. Connection of Hydraulic Hoses	II- 6
	F. Bleeding Hydraulic Clamp Hoses	II- 9
	G. Filling Vibrator Pressure Hose	II- 9
III.	<u>OPERATING INSTRUCTIONS</u>	
	Control Panel with Remote Pendant	III- 2
	A. Completion of Set-Up and Maintenance	III- 3
	B. Control Panel	III- 3
	C. Starting and Warming Up Engine	III- 4
	D. Warming Hydraulic Fluid	III- 4
	E. Operation of Control Pendant	III- 5
	F. Changing Frequency	III- 6
	G. Shutdown	III- 6
IV.	<u>MAINTENANCE AND ADJUSTMENTS</u>	
	A. General	IV- 1
	B. Daily	IV- 1
	C. 100 Hours, 500 Hours and Other	IV- 2
	D. Annually	IV- 2
	E. Severe Conditions	IV- 3
	F. Lubrication	IV- 3
	G. Capacities	IV- 7
	H. Draining and Filling Hydraulic Fluid Reservoir	IV- 8
	I. Changing Hydraulic Return Filter Element	IV- 8
	J. Bolt Torque Information	IV- 9



**MODEL 23
VIBRATORY
DRIVER/EXTRACTOR**

TABLE OF CONTENTS

V.	<u>HYDRAULIC CIRCUITRY</u>	<u>PAGE</u>
	A. Hydraulic Clamp / Vibratory Drive	V- 2
	B. Other	V- 3
	Hydraulic Schematic	V- 4
	C. Hydraulic Components List	V- 5
VI.	<u>ELECTRICAL CIRCUITY</u>	
	A. Starting Diesel Engine	VI- 1
	B. Stopping Diesel Engine	VI- 1
	C. Safety Control System	VI- 1
	D. Closing Clamp / Starting Vibrator	VI- 3
	E. Stopping Vibrator	VI- 3
	F. Opening Hydraulic Clamp	VI- 3
	G. Other	VI- 3
	Electrical Schematic	VI- 4
	H. Electrical Components List	VI- 5
VII.	<u>GENERAL DATA</u>	
	A. Abbreviations	VII- 1
	B. Screws and Bolts	VII- 1
	C. Serial Number Locations	VII- 2
VIII.	<u>ORDERING PARTS</u>	
	A. Procedure	VIII- 1
	B. Fitting Description Key	VIII- 2
	Fitting Style Selector Chart - SC1	VIII- 3
	C. Hose Description Code	VIII- 4
	D. Parts Identification	VIII- 5
	Parts Lists and Drawings	VIII-6-VIII-29
	E. Miscellaneous Accessories	VIII-30
	F. Recommended Spare Parts	VIII-30
	G. Recommended Tightening Torque	VIII-32



**MODEL 23
VIBRATORY
DRIVER/EXTRACTOR**



**MODEL 23
VIBRATORY
DRIVER/EXTRACTOR**

**OPERATING
INSTRUCTIONS**

A. GENERAL

The J&M Model 23 is a low-frequency vibratory pile driver/extractor designed to drive and extract vinyl, aluminum and steel sheet piles.

The Model 23 operates in a frequency range of 800 to 1800 vibrations per minute to provide maximum pile penetration rates in a wide variety of soils. The unit has an eccentric moment of 230 inch-pounds (2.6 kg-M) and produces a maximum amplitude of 1.0 inch (25 mm).

The vibratory driver unit consists of two major components. (1) The vibrator with attached clamp and (2) the hydraulic power unit with control pendant.

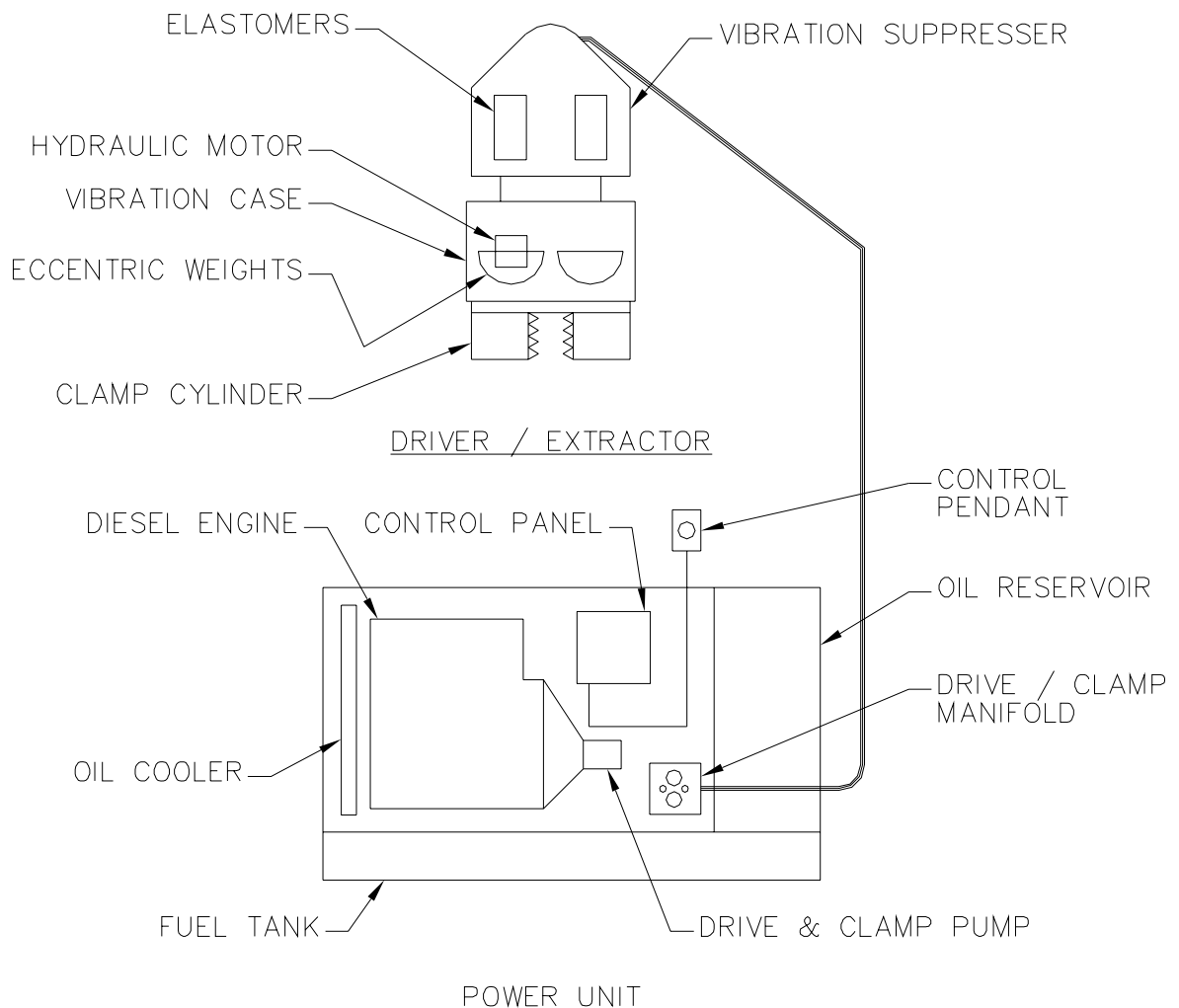



MODEL 23
VIBRATORY
DRIVER/EXTRACTOR

OPERATING INSTRUCTIONS

I. GENERAL DESCRIPTION

B. VIBRATOR

The vibrator consists of two major components; The vibration case and the vibration suppressor. The vibration case contains two eccentric weights which rotate in a vertical plane to create vibration. The eccentric weights are driven by a hydraulic motor. The vibration suppressor contains 4 rubber elastomers to isolate the vibration case from the crane line. The suppressor is designed for a maximum line pull of 13 tons (116kN) during extraction.

C. HYDRAULIC CLAMP

The hydraulic clamp attaches the vibrator to the pile, transmitting vibration to the piling. The hydraulic clamp contains two gripping jaws; one fixed and one moveable. A large hydraulic cylinder operates the moveable jaw with 20 tons (178kN) of force to grip the pile. Clamping and un-clamping occurs in a few seconds.

INFORMATION

Consult J&M in your area for any other clamp questions regarding other than what is stated herein.

D. POWER UNIT

The Model 23 vibrator is powered by the J&M Model 51 Power pack. The 51 power pack is powered by a Caterpillar C-2.2 diesel engine. The engine develops 51 gross horsepower (38kW) at 3000 RPM, and is mounted on a tubular sub-base which serves as a fuel tank. The Power Unit and Vibrator are operated from the control pendant.

E. HOSES

A hydraulic hose bundle (multiple hoses) connects the hydraulic power unit to the vibrator unit.



**MODEL 23
VIBRATORY
DRIVER/EXTRACTOR**

**OPERATING
INSTRUCTIONS**

I. GENERAL DESCRIPTION

F. CONTROL PENDANT

The vibrator is operated by a hand-held control pendant. The control pendant has one, two-way switch. This switch (CLAMP OPEN-OFF-FWD) starts and stops the vibrator as well as opens and closes the clamp. Turning the switch to FWD first closes the clamp. When adequate clamp pressure is reached the vibrator will start. Turning the switch to off stops the vibrator. Turning the switch and holding it at CLAMP OPEN after the vibrator is stoped the clamp will open.

G. SPECIFICATIONS

1. Constant improvement and engineering progress make it necessary that we reserve the right to make specification changes without notice.

INFORMATION Always consult J&M in your area for current or additional information you may require.

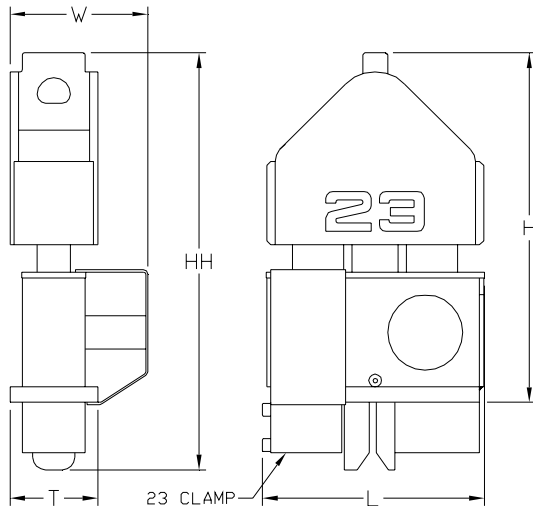

2. Model 23 VIBRATOR (with hydraulic clamp)
 - Type..... Hydraulic
 - Eccentric Moment..... 230 In-lbs. (2.6kg-M)
 - Frequency 800-1800 VPM
 - Amplitude 0.58 in. (15 mm)
 - Pile Clamping Force 20 Tons (178kN)
 - Max. Line Pull for
 - Extraction 13 Tons (116kN)
 - Weight with Clamp2,100 lbs. (953kg)
 - Length [L] 26.50 in. (67cm)
 - Width [W]..... 22 in. (56cm)
 - Throat Width [T]..... 10.50 in. (27cm)
 - Height with Clamp [HH] 55 in. (140cm)
 - Height without clamp [H] 47 in. (119cm)

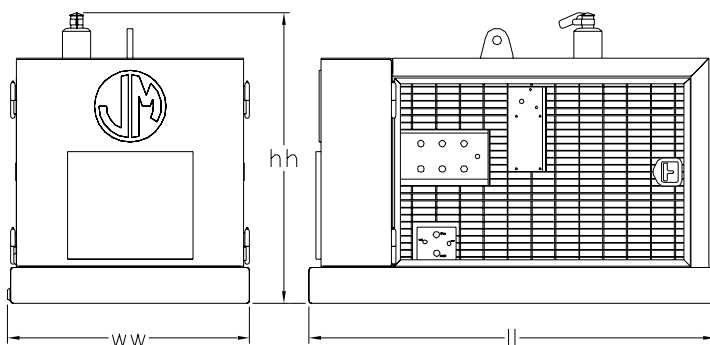

3. MODEL 51 POWER UNIT
 - Type..... Diesel
 - Engine CAT C-2.2
 - Horsepower (3000 RPM)..... 51 (38 kW)
 - Weight2,700 lbs. (1225kg)
 - Length[ll] 68 in. (173cm)
 - Width [ww] 41.31 in. (105cm)
 - Height [hh] 48.75 in. (124cm)



MODEL 23
VIBRATORY
DRIVER/EXTRACTOR

OPERATING INSTRUCTIONS



MODEL 23
VIBRATORY
DRIVER/EXTRACTOR

OPERATING INSTRUCTIONS

II. PREPARATION FOR OPERATION

A. GENERAL



When unloading and unpacking the vibratory driver, use extreme care. For your protection, make a thorough inspection of the unit immediately on delivery. In case of any damage or shortage, notify the transit agent at once and have the delivering carrier make a notation on the freight bill.

B. SAFETY PRECAUTIONS

Safety is very important and is everyone's responsibility that operates this equipment or services this equipment.



Use the following safety precautions as a general guide to safe operations, when in doubt consult J&M before proceeding with any operation that may produce an unsafe result. These safety guidelines do not constitute all possible safety issues that may occur during operation or maintenance.

1. Read this manual thoroughly before operating or working on the equipment.
2. Read and follow any safety instructions in the CATERPILLAR engine operators manual.
3. Only well trained and experienced personnel should attempt to operate or maintain this equipment.
4. Never adjust, lubricate or repair the unit when it is in operation, or lifted above ground level.
5. Never remove, paint over or cover warning or safety labels. If labels become damaged or unreadable, replace immediately.
6. All personnel should wear approved safety clothing, including **HARD HATS, SAFETY SHOES, SAFETY GLASSES** and **HEARING PROTECTION** when in the vicinity of this machinery.
7. Do not stand any closer to this equipment than necessary when it is in operation. Parts may loosen and fall. Never stand under operating, or elevated, equipment.
8. When maintaining or repairing the equipment, never substitute parts not supplied, or approved in writing, by J&M.
9. Do not weld, or flame cut, on this equipment.
10. Never use or store flammable liquids on or near the engine.
11. Insure that all lifting equipment, including cranes, wire rope, slings, hooks, shackles, etc., are properly sized for the worst case loads anticipated during operations.
12. If there are any questions about the weights, specifications, or performance of the unit, contact J&M before handling or operating the equipment.
13. If the equipment is to be used for anything other than driving or extracting plumb piles, contact J&M before using the unit.
14. Check wire rope clips for tightness, and check wire ropes for wear, daily.



**MODEL 23
VIBRATORY
DRIVER/EXTRACTOR**

**OPERATING
INSTRUCTIONS**

II. PREPARATION FOR OPERATION

B. SAFETY PRECAUTIONS (CONTINUED)

15. Insure that ground vibrations will not damage or collapse adjacent structures or excavations.
16. Remove all tools, parts and electrical cords before starting the unit.
17. When operating in an enclosed area, pipe exhaust fumes outside. Continued breathing of exhaust fumes may be fatal.
18. When servicing batteries, do not smoke or use open flames in the vicinity. Batteries generate explosive gas during charging. There must be proper ventilation when charging batteries.
19. When filling fuel tank, do not smoke or use open flame in the vicinity.
20. If abnormal equipment operation is observed, discontinue use immediately and correct the problem. Do not leave the equipment control pendant (radio control) unattended.
21. Store oily rags in approved containers, and away from engine exhaust system.
22. Make sure that the vibrator is OFF before starting the power unit engine.
23. Do not adjust, or set, hydraulic pressures higher or lower than those specified in this manual.
24. Never operate this equipment with hydraulic hoses that are damaged or "kinked". Replace damaged hoses immediately.
25. Do not lift, or support, hydraulic hoses with wire rope slings.
26. Never attempt to connect quick disconnects when the power unit is running.
27. Do not pull on, or attempt to move equipment, with hydraulic hoses.
28. Do not attempt to locate hydraulic leaks with your hands. High pressure hydraulic leaks can penetrate the skin, causing severe damage, blood poisoning and infection. Do not attempt to repair leaks while the equipment is in operation.
29. Do not attempt to tighten, or loosen, fittings or hoses when the machine is in operation.
30. Power unit must always be placed on level, stable, ground.
31. Do not remove power unit heat shields, or operate power unit without heat shields. Severe fires may result.
32. A properly maintained fire extinguisher, suitable for oil fires, must be kept in the immediate vicinity of equipment operations.
33. When moving or transporting this equipment, insure that the vehicle or vessel is of sufficient capacity to handle the load, and that the equipment is properly tied down.
34. When moving or transporting this equipment, be sure that quick disconnect dust caps are tight, and that cap safety cables are in place. Be sure that all equipment parts are tight, or properly secured, before shipment. Unsecured parts may vibrate loose and fall, during transport, causing injury or property damage.
35. Keep crane boom, piles, leads, wire rope and other equipment at least 15' (5M) from electrical power lines, transformers and other electrical equipment, or at such distance as required by applicable safety codes.



**MODEL 23
VIBRATORY
DRIVER/EXTRACTOR**

**OPERATING
INSTRUCTIONS**

II. PREPARATION FOR OPERATION

B. SAFETY PRECAUTIONS (CONTINUED)

36. Rounded or damaged bolt heads or nuts should be replaced so that proper torque values may be obtained. Proper torque values are necessary to prevent parts on this equipment, leads and crane boom from loosening and falling. Refer to Torque Chart, in this manual, for proper values.
37. Do not use the vibrator clamp to move piles we recommend using a safety line in case of loss of hydraulic pressure.
38. Never clamp vibrator to pile and disconnect the crane line. Loss of hydraulic pressure could cause vibrator to fall. Lay vibrator down when not in use.
39. When extracting piles, always attach a safety line between pile and crane hook.
40. When extracting piles, check crane load/radius tables to be sure crane capacity is adequate for maximum allowable extraction pull.
41. When extracting piles, or any other driving operations, always be sure that the crane line is aligned with the centerline of the pile. Do not side load crane boom or vibrator. Dangerous crane boom, or vibrator, damage may result.
42. When extracting piles, do not exceed the capacity of the vibrator suppressor. Continued operation against the safety stops will cause damage to the crane boom and the vibrator.
43. Never induce line pull on a vibrator before starting the unit in vibration. Always start both driving and extraction of piles with a slack line.
44. Keep hands away from clamp jaws.
45. Keep hands away from vibrator suppressor during operation. Clearances may change causing pinch points.
46. Do not run vibrator unless clamp jaws are closed.
47. Use tag line to control vibrator whenever possible.
48. When driving "batter" piles, insure that the leads, and crane boom, have sufficient bending strength to handle the worst case load. Consult J&M.

REMEMBER, SAFETY IS EVERYONE'S BUSINESS.



MODEL 23
VIBRATORY
DRIVER/EXTRACTOR

OPERATING INSTRUCTIONS



MODEL 23
VIBRATORY
DRIVER/EXTRACTOR

OPERATING INSTRUCTIONS

II. PREPARATION FOR OPERATION

C. RIGGING OF VIBRATOR

A steel wire rope sling must be connected to the lifting bale of the vibration suppressor. The required strength of this sling depends on the capacity of the crane and the work to be carried out. A safety factor of five is recommended. Several turns of a smaller diameter cable will usually last longer than one turn of a larger diameter cable.



All rigging of either the hydraulic power unit or vibrator must be done in accordance with standard rigging guide lines set forth in ASTM standards; J&M does not assume responsibility for incorrect rigging or procedures.

D. CONNECTION OF HYDRAULIC CLAMP

The vibrator is usually shipped with the hydraulic clamp already attached.

If the clamp is not attached, it will be necessary to attach it to the bottom of the vibrator. Orient the clamp to the vibrator with the clamp cylinder end (movable jaw) at the same end of the vibrator as the motor is mounted. All ten (1.0-8UNC x 7.50) bolts must be in place and torqued to approximately 1009 ft-lbs (139Kg-M) and the one (0.75-10UNC X 7.50) bolt torqued to approximately 417 ft-lb (57Kg-M).



**MODEL 23
VIBRATORY
DRIVER/EXTRACTOR**

**OPERATING
INSTRUCTIONS**

II. PREPARATION FOR OPERATION

E. CONNECTION OF HYDRAULIC HOSES

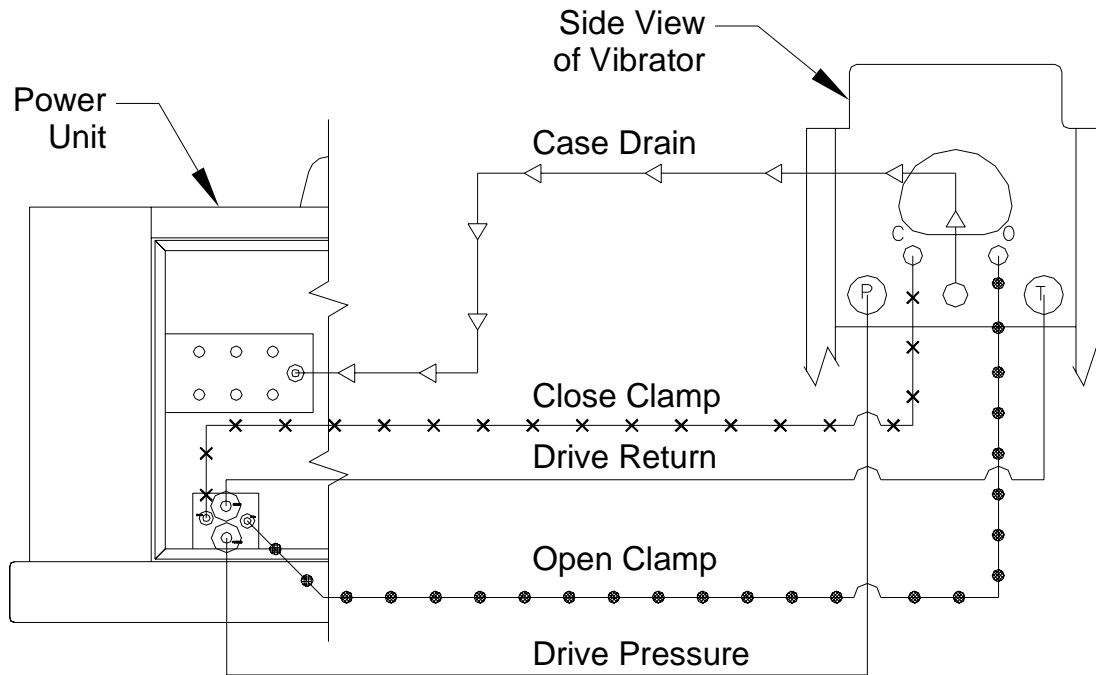

(Fig. 1)

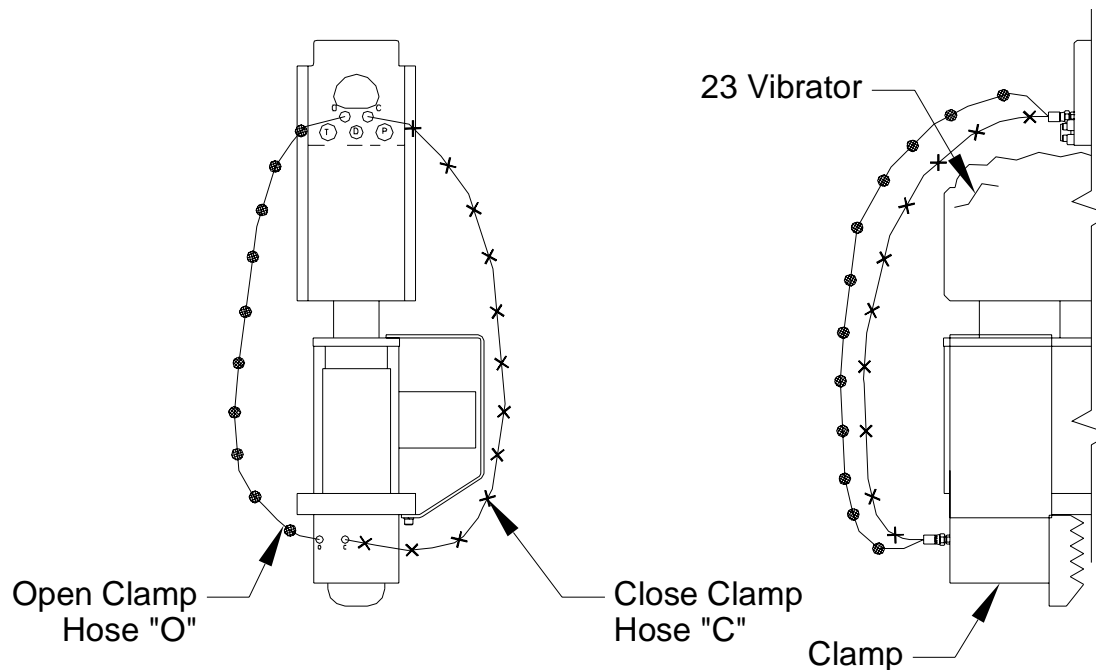

(Fig. 2)



MODEL 23
VIBRATORY
DRIVER/EXTRACTOR

OPERATING INSTRUCTIONS

II. PREPARATION FOR OPERATION

E. CONNECTION OF HYDRAULIC HOSES

1. Connection of hoses at power unit.

a. The vibrator and hydraulic clamp are connected to the power unit by five hydraulic hoses (Fig. 1) on the previous page.

 **DANGER** The power unit must be shut down during connection of the hydraulic hoses.

b. The hoses connect to the power unit with quick-disconnect couplers. Hose couplers are arranged to insure correct connections at the power unit. See the diagram (Fig. 1) for correct hose connection.

c. Clean couplers with a lint-free cloth before making connections.

 **WARNING** Do not use engine starting fluid to clean quick disconnects, this will damage the seals and result in an oil leak.

d. Make sure that the couplers are fully run up, and hand tightened only, do not use wrenches to over tighten.

2. Connection of hoses at vibrator.

a. The vibrator is usually shipped with the hoses attached to the vibrator. If the hoses have been shipped separately, they must be connected in the field. Fig. 1 shows the correct arrangement of the five hoses connecting the power unit to the vibrator.

 **WARNING** Starting the vibrator with the hoses reversed will result in low power or possible ruptured hoses.

b. The vibrator is usually shipped with the hydraulic clamp and hoses attached. If the clamp has been shipped separately, the two hoses connecting the clamp to the vibrator must be connected. (Fig. 2) shows the correct arrangement of these hoses.



MODEL 23
VIBRATORY
DRIVER/EXTRACTOR

OPERATING INSTRUCTIONS



**MODEL 23
VIBRATORY
DRIVER/EXTRACTOR**

**OPERATING
INSTRUCTIONS**

III. PREPARATION FOR OPERATION

F. BLEEDING HYDRAULIC CLAMP HOSES

1. When the vibrator and hydraulic clamp are shipped with all hoses attached (between vibrator and clamp and five main hoses connected to the vibrator), the hoses are usually full of fluid and may be used immediately. However, if any of the clamp hoses are connected at the jobsite or if air is present in hoses, they must be bled prior to operation.
2. Read SECTION III - OPERATING INSTRUCTIONS.



Use caution when bleeding any hydraulic lines, even low hydraulic pressure can cause injury to personnel.

3. Start and warm up the diesel engine in accordance with SECTION III-C - STARTING AND WARMING UP ENGINE.
4. With the engine warmed-up and running at 1500 RPM, loosen the close-clamp line at the hydraulic clamp. Turn the switch on the control pendant to FWD. Wait until fluid flows from the connection at the hydraulic clamp. When fluid flows without air, tighten the connection and return switch to STOP.



Note: When the jaw closes and pressure builds the vibrator will start. Turn the switch back to STOP before this happens.

5. After the line has been bled, alternately turn the switch to FWD and OPEN to insure that the clamp is working properly. It may be necessary to bleed the line more than once. The open-clamp line may also require bleeding.

G. FILLING VIBRATOR PRESSURE HOSE

1. The vibrator is usually shipped with the vibrator hydraulic hoses full of fluid and the unit may be used immediately. However, if the pressure hose has been removed from the vibrator, the hose should be allowed to fill with hydraulic fluid prior to full speed operation.
2. Read SECTION III - OPERATING INSTRUCTIONS.
3. Start and warm up the diesel engine in accordance with SECTION III-C - STARTING AND WARMING UP ENGINE. Hold the vibrator in a vertical position.
4. With the engine warmed up and running at 1000 RPM, turn and hold the vibrator switch FWD. The hoses will fill and the vibrator will start and is ready to be used.



**MODEL 23
VIBRATORY
DRIVER/EXTRACTOR**

**OPERATING
INSTRUCTIONS**

III. OPERATING INSTRUCTIONS

CONTROL PANEL WITH CONTROL PENDANT

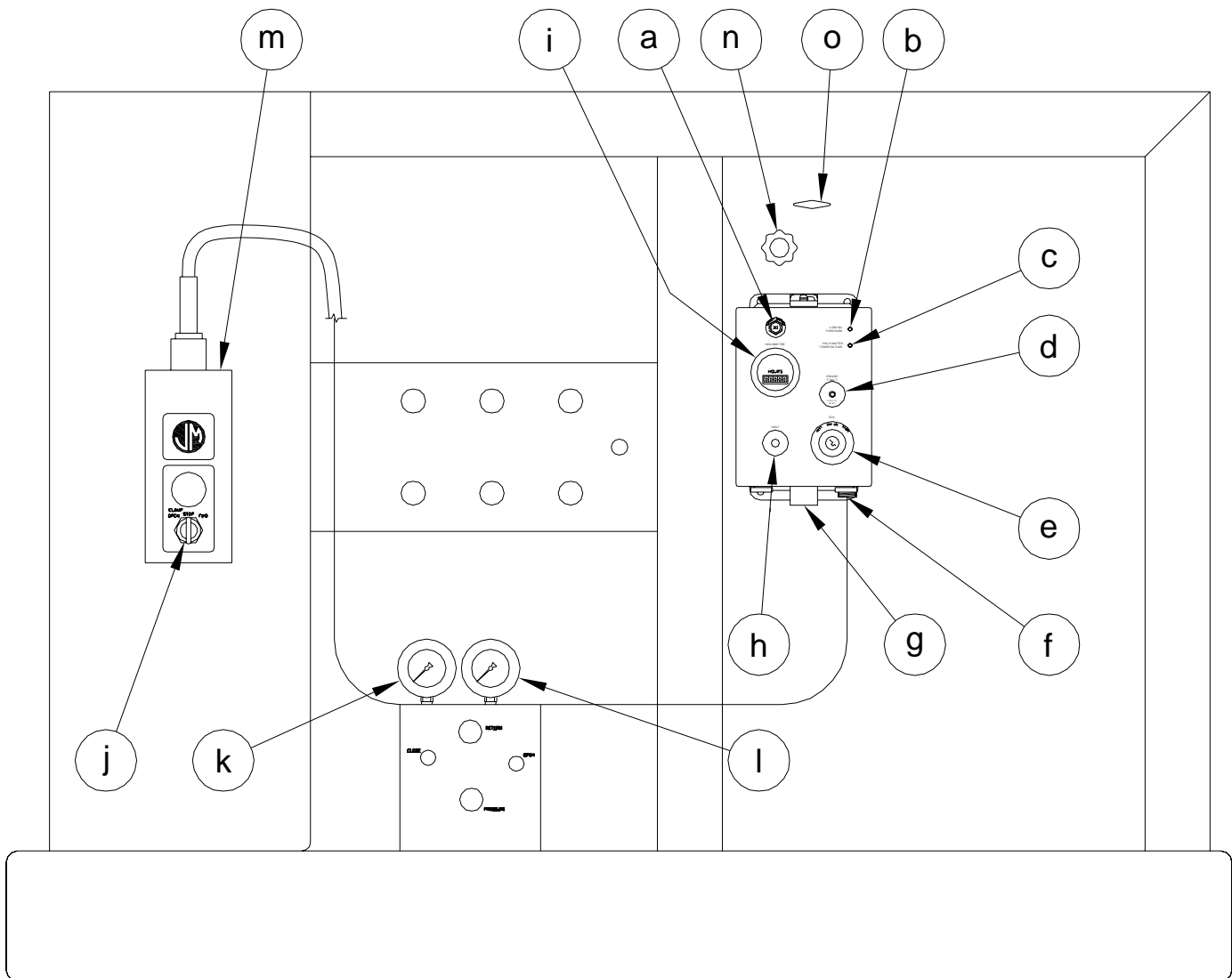

(Fig. 1)



**MODEL 23
VIBRATORY
DRIVER/EXTRACTOR**

**OPERATING
INSTRUCTIONS**

III. OPERATING INSTRUCTIONS

A. COMPLETION OF SET-UP AND MAINTENANCE

1. Complete all preparation as described in Section II.
2. Read Section IV - MAINTENANCE AND ADJUSTMENTS and perform any required maintenance.

B. CONTROL PANEL

1. The control box (Fig. 1, page III-2) at the side of the power pack contains the controls and gages for the diesel engine, vibrator, and the OPERATION AND MAINTENANCE INSTRUCTIONS.
2. Control panel contains the following controls and gages:
 - a. Main power switch (Circuit Breaker) - on/off switch for 24 volt electrical power.
 - b. Low Engine oil pressure indicator light.
 - c. High water temperature indicator light.
 - d. Engine shut-down reset button - on start must be held in until oil pressure exceeds 30 PSI.
 - e. Engine "ON/OFF/START" switch - for diesel engine.
 - f. S/O connector for power to the control valve manifold.
 - g. Engine wire harness connector.
 - h. Engine Glow Plug indicator.
 - i. Engine hour meter.
 - j. Clamp / Vibrator switch.
 - k. Pressure gage - (Close).
 - l. Pressure gage - (System - Forward).
 - m. Control Pentant.
 - n. Engine Throttle knob.
 - o. Emergency Stop handle.

- Notes:
1. Low Engine Oil Pressure shutdown indicator - comes on if the engine has been shut down automatically due to engine oil pressure being low.
 2. High Engine Water Temperature shutdown - comes on if the engine has been shut down automatically due to engine water overheating.



3. The OPERATION AND MAINTENANCE INSTRUCTIONS on the control panel are there as reminders only. They are not complete and therefore not intended to substitute for a thorough understanding of this Operating Manual.



**MODEL 23
VIBRATORY
DRIVER/EXTRACTOR**

**OPERATING
INSTRUCTIONS**

III. OPERATING INSTRUCTIONS

C. STARTING AND WARMING UP ENGINE

1. Before starting the engine, read the CATERPILLAR OPERATION GUIDE carefully. Follow the engine starting, operating and maintenance procedures in that manual.
2. The diesel engine should not be started if the temperature of the hydraulic fluid is below 0°F(-18°C). The temperature may be read on the gage on the hydraulic reservoir.
3. The MAIN POWER SWITCH on the control panel should be ON. The vibrator switch (CLAMP OPEN / STOP / FOR) on the control pendant should be in the STOP position.
4. Hold SHUTDOWN RESET button in and turn the ENGINE START switch to the HEAT position. Hold there for 6 seconds until the glow plug indicator light illuminates. While the glow plug indicator is illuminated, turn the engine start switch to the START position. If the engine fails to start after 30 seconds of cranking, allow the starter to cool for two minutes before repeating the starting procedure. When temperature is below
5. As the engine starts, release the ENGINE START switch. It will return to the RUN position.
6. Adjust the throttle until the engine is running at 1500 RPM and allow to warm-up for five minutes.
7. Allow the temperature of the hydraulic fluid to come up to at least 30°F(-1°C) before starting vibrator.

 **DANGER** Do not use aerosol types of starting aids such as ether.

D. WARMING HYDRAULIC FLUID

1. The vibrator should not be operated at full speed if the temperature of the hydraulic fluid is below 70°F(21°C).
2. If temperature of the hydraulic fluid is below 70°F(21°C), set the diesel engine at 1500 RPM and run the vibrator at reduced speed until the temperature of the hydraulic fluid exceeds 70°F(21°C).
3. When the engine is warmed up and hydraulic fluid temperature is at least 70°F(21°C), full speed operation may begin. Adjust the throttle so the engine is running at full RPM unloaded.

 **WARNING** Do not operate the vibrator if hydraulic fluid temperature exceeds 180°F(82°C) as this may damage hydraulic components.



MODEL 23
VIBRATORY
DRIVER/EXTRACTOR

OPERATING INSTRUCTIONS

III. OPERATING INSTRUCTIONS

E. OPERATION OF CONTROL PENDANT

1. The operation of the vibratory driver is controlled by the control pendant. The pendant is connected to the control valve with 50 feet of electrical cable to permit operation from any advantageous position to view the vibrator.
2. The pendant has one, three-way switch.
 - a. To Clamp to Pile and Start Vibration:

Position vibratory driver on pile. Turn the switch on the pendant to FWD. The clamp will close and hydraulic pressure will increase pressure to permit vibration to begin.

- b. To Stop Vibration:

Turn the vibrator switch to OFF.

- c. To Unclamp from Pile:

Turn the switch to CLAMP OPEN to release the hydraulic clamp so that the vibrator can be moved from the pile. Hold the switch in the CLAMP OPEN position until the jaws are fully open.

 **DANGER** Do not turn the switch to CLAMP OPEN until a visual check indicates that vibration has stopped.

- e. To change engine speed:

Turn the Throttle knob (ENGINE THROTTLE) counter clockwise to decrease the engine speed. Turn the knob clockwise to increase the engine speed. Depressing the button in the center of the knob and pushing the knob all the way in will set the engine RPM to low idle. Depressing the button in the center of the knob and pulling the knob all the way out will set the engine RPM to high idle.

- f. Emergency stop handle:

Pull the EMERGENCY STOP handle out and all operating functions will cease to operate. Diesel engine and vibrator will stop immediately.

- g. If the control pendant is damaged or the pendant line is cut, you will not be able to operate the vibrator.



MODEL 23
VIBRATORY
DRIVER/EXTRACTOR

OPERATING INSTRUCTIONS

III. OPERATING INSTRUCTIONS

F. CHANGING FREQUENCY

1. In order to provide maximum flexibility in achieving optimum pile penetration and extraction rates, the frequency of the vibratory driver is adjustable.
2. The frequency can be varied from 800 to 1800 vibrations per minute by changing engine speed. Engine speed is changed with the ENGINE THROTTLE knob (SLOW-FAST) on the control panel. Vibrator frequency corresponds to engine speed.

G. SHUT DOWN

1. Stop the vibrator.
2. Allow the diesel engine to run for five minutes at about 1500 RPM.
3. Reduce speed to low idle for about thirty seconds.
4. Stop the engine by turning the ENGINE START switch to OFF. (Engine may also be stopped by pulling in the EMERGENCY STOP handle on the Control Panel.)



If the diesel engine is shut down while the vibrator is clamped to a pile, the clamp check valve will keep the vibrator clamped to the pile. However, system leakage could result in a loss of clamp pressure over time. Therefore, it is not recommended to leave the vibrator clamped to a pile when the diesel engine is not running.



MODEL 23
VIBRATORY
DRIVER/EXTRACTOR

OPERATING INSTRUCTIONS

IV. MAINTENANCE AND ADJUSTMENTS

A. GENERAL

Preventive maintenance includes normal servicing that will keep the vibratory driver, clamp and power unit in peak operating condition and prevent unnecessary trouble from developing. This servicing consists of periodic lubrication and inspection of the moving parts and accessories of the unit.

Lubrication is an essential part of protective maintenance, controlling to a great extent the useful life of the unit. Different lubricants are needed and some components in the unit require more frequent lubrication than others. Therefore, it is important that the instructions regarding types of lubricants and frequency of their applications be closely followed.

To prevent minor irregularities from developing into serious conditions that might involve shut-down and major repair, several other services or inspections are recommended for the same intervals as the periodic lubrications. The purpose of these services or inspections is to assure the uninterrupted operation of the unit.

Thoroughly clean all lubrication fittings, caps, filler and level plugs and their surrounding surfaces before servicing. Prevent dirt from entering with lubricants and coolants. The intervals given in the schedule are based on normal operation. Perform these services, inspections, etc., more often as needed for operation under abnormal or severe conditions.

B. DAILY

1. Check the entire unit prior to and during set-up each day or at the beginning of each shift.
2. Prior to starting the power unit or at the beginning of each shift, check the following items:
 - a. Visibly inspect all bolts, nuts and screws, including the bolts fastening the hydraulic clamp to the vibration case, to insure they are tight.

▲ CAUTION Vibration loosens bolts - check carefully.

- b. Tighten bolts holding gripping jaws in hydraulic clamp.
- c. Grease plunger in hydraulic clamp with any good multi-purpose grease.
- d. Check the oil level in the vibration case and add oil if required. The oil level should be in the middle of the sight glass. Change oil if milky or contaminated. DO NOT OVERFILL
- e. Check the fluid level in the hydraulic reservoir and refill if necessary.

▲ CAUTION It is absolutely imperative that no dirt or other impurities be permitted to contaminate the hydraulic fluid. Any contamination will drastically shorten the life of the high-pressure hydraulic system.



MODEL 23
VIBRATORY
DRIVER/EXTRACTOR

OPERATING INSTRUCTIONS

IV. MAINTENANCE AND ADJUSTMENTS

B. DAILY (CONTINUED)

- f. Visually check all hoses for signs of damage or cuts that might cause hose failure during operation. Be sure all connections are tight, especially the quick-disconnect couplers.
- g. Visually inspect all suppressor elastomers and elastomer bolts.
- h. Electrical components need no maintenance except periodic wiping with a clean, dry, lint-free cloth to remove dust.
- i. Perform all daily maintenance checks and lubrication indicated in the CATERPILLAR OPERATION GUIDE.

3. After engine start-up, check the following:

- a. Check all hydraulic hoses for leaks. Make sure they hang freely with no kinks.
- b. Check pump and all hydraulic manifolds for leaks.
- c. Check the filter indicators. 0-17psi = Filter Clean, 18-23psi = Change Filter, 24 + psi = Filter Clogged. The return filter on the power pack must be checked with the diesel engine running at full speed.

C. 100 HOURS, 500 HOURS AND OTHER

1. Every 100 hours, drain and add new lubricant in the vibration case.
2. Perform all maintenance checks and lubrication indicated in the CATERPILLAR OPERATION GUIDE.

D. ANNUALLY

1. Have the hydraulic fluid tested by a local hydraulic service center or oil company. Replace if required.

INFORMATION The frequency with which hydraulic fluid requires changing depends both on the condition of the fluid and the operating conditions involved. The most accurate method for determining how often fluid should be changed is to have a laboratory fluid analysis done periodically.

2. See Caterpillar OPERATION GUIDE.



**MODEL 23
VIBRATORY
DRIVER/EXTRACTOR**

**OPERATING
INSTRUCTIONS**

IV. MAINTENANCE AND ADJUSTMENTS

E. SEVERE CONDITIONS

The servicing intervals specified are based on normal operating conditions. Operation under severe or unusual conditions will require some adjustments in servicing intervals.

1. When the average temperature is above 80°F(26°C) or below -10°F(-23°C), reduce service time intervals by one-half of those specified above.
2. When operating in the presence of dust or sand, reduce service time intervals by one-half of those specified.
3. When operating in excess of twelve hours per day, reduce service time intervals by one-half of those specified.
4. When operating in air with high moisture or salt, the servicing intervals need not usually be changed. However, the unit should be inspected weekly to determine if additional servicing be required. Also, have hydraulic fluid tested quarterly.
5. For extended inactive periods, the engine should be started at least once a week and run until thoroughly warm. Servicing time intervals may be extended from those specified, but for actual time intervals, contact your local Caterpillar dealer, especially during lengthy storage periods.

F. LUBRICATION

1. Crankcase (Diesel Engine)
 - a. Follow the engine manufacturer's maintenance schedule and the lubricating oil specifications outlined in the CATERPILLAR OPERATION GUIDE.
 - b. The lubricant shall meet the performance requirements of API Service Classifications CH-4.
 - c. New engines are shipped with Caterpillar SAE 15W-40 but the following multi-grade crankcase oils are recommended for use or replacement in normal operation (10°F to 90°F) (-12°C to 32°C).



**MODEL 23
VIBRATORY
DRIVER/EXTRACTOR**

**OPERATING
INSTRUCTIONS**

IV. MAINTENANCE AND ADJUSTMENTS

F. LUBRICATION (CONTINUED)

ASHLAND	15W-40	400M + HDT
AMOCO	15W-40	300
ARCO	15W-40	Fleet S3 Plus
BORON (BP)	15W-40	Vanellus C Extra
CHEVRON	15W-40	Delo 400
CITGO	15W-40	C500 Plus
CONOCO	15W-40	Fleet Supreme
EXXON	15W-40	XD3
GULF	15W-40	Super Duty Plus
MOBIL	15W-40	Delvac Super
PHILLIPS	15W-40	Super HD II
SHELL	15W-40	Rotella T
SUN	15W-40	Sunfleet Super C
TEXACO	15W-40	Ursa Super Plus
UNION	15W-40	Guardol
VALVOLINE	15W-40	All Fleet

- d. For operation in extreme sub-zero climate, refer to the CATERPILLAR OPERATION GUIDE Crankcase Lubricating Oils or contact the nearest Caterpillar representative. (CAT bulletin #SEBU5898-06)

2. Hydraulic System

To maintain the maximum operating efficiency in the precision parts of the hydraulic system, it is extremely important to eliminate factors which can cause breakdowns or unsatisfactory performance in the system. Among the most common of these factors are rust, corrosion, contamination and products of oil deterioration. Most problems can be minimized or avoided simply by maintaining a disciplined preventive maintenance program.

Some simple steps to follow as part of that program are:

- Keep stored oil dry and clean at all times and always store in clean containers.
- Always clean tools, spouts, lids, funnels, etc. when used in conjunction with the transfer of oil.
- Never put dirty oil into the hydraulic system. Use only clean, uncontaminated oil of the types recommended below. Never return to the system any fluid which has leaked out.

NOTE: Foreign material in the hydraulic system can drastically effect the life and operation of many hydraulic component parts.

- Clean or replace filter elements at the first indication that they are dirty or ineffective.



MODEL 23
VIBRATORY
DRIVER/EXTRACTOR

OPERATING INSTRUCTIONS

IV. MAINTENANCE AND ADJUSTMENTS

F. LUBRICATION (CONTINUED)

Mixing of different manufacturers' hydraulic fluid is not recommended.

INFORMATION

New power units are shipped with Terresolve Invirological 146 Hydraulic oil. This oil is non-toxic and will not harm soil or water and is biodegradable. Adding any other oil from the list below, will contaminate the Terresolve oil and the system will no longer be environmentally friendly.

Should the customer choose to use an alternate oil, the following recommendations may be used when replacing fluid in the hydraulic system.

FIRST Preference Group:

TERRESOLVE	Invirological 146
CHEVRON	Clarity AW46
MOBIL	DTE-15
SUN	2105

SECOND Preference Group:

ARCO	Duro AW46
CHEVRON	Hydraulic AW46
PHILLIPS	Magnus A46
SHELL	Tellus 46

THIRD Preference Group:

BORON	Energol HLP46
CITGO	A.W. Hydraulic 46
CONOCO	Super 46
EXXON	Nuto H46
GULF	Harmony 46AW
SUN	Sunvis 846
TEXACO	Rando HD AZ46
UNION	Unax AW46

INFORMATION

Whenever fluids from the second preference group are used, it is necessary to test the oil more often to insure that viscosity remains within recommended limits while in service. Using fluids from the third preference group requires even a more discerning inspection than use of fluids from the second group.

The recommended fluids were chosen based on the hydraulic system operating temperature range being 5°F (-15 °C) (cold ambient start-up) to 180°F (82°C) (maximum operating).



MODEL 23
VIBRATORY
DRIVER/EXTRACTOR

OPERATING INSTRUCTIONS

IV. MAINTENANCE AND ADJUSTMENTS

F. LUBRICATION (CONTINUED)

INFORMATION

When operating in arctic conditions, it is recommended to use an immersion heater to pre-heat the oil prior to starting. Contact J&M for other arctic operating procedures. It may also be necessary in extremely cold or hot climates to use a different viscosity oil which is better adapted to adverse conditions. Contact the nearest oil supply representative for suggested procedures.

TERRESOLVE Invirological 146 hydraulic fluid is available from J&M in five gallon cans. See SECTION VIII - ORDERING PARTS.

3. Vibration Case

The fluid level is easily read through the sight glass located at the lower center of the vibration case on the motor side. Lubricating oil may be added when necessary, through the hole in the vibration case top plate after removing the 3/4" pipe plug. To drain the case, remove the sight glass. Tilt the case for complete drainage.

4. The preferred lubricating oil for J&M vibration cases is "High Moly" oil (Schaeffer 268). Longer intervals between fluid changes and fewer maintenance hours spent on mechanical service can generally be realized with this fluid.

Therefore, whenever the "first preferred" oil is not available, or desired, and an alternate fluid is selected, it will be necessary to test and/or change the oil at shorter intervals.

Extensive tests have indicated that the use of Schaeffer 268 results in cooler operation and extended bearing and gear life.



**MODEL 23
VIBRATORY
DRIVER/EXTRACTOR**

**OPERATING
INSTRUCTIONS**

IV. MAINTENANCE AND ADJUSTMENTS

F. LUBRICATION (CONTINUED)

- a. The vibration case and multi-pump drive adapter lubricants installed at the factory are SCHAEFFER 268 but the following gear lubes may be used when changing lubricants:

FIRST Preference Group:

SCHAEFFER 268

SECOND Preference Group:

MOBIL	SHC-634
BORON	Gearep 140
CHEVRON	Gear Comp. NL460
CITGO	Premium MP 85W-140
CITGO	Standard MP 85W-140
GULF	Lub 85W-140
PHILLIPS	MP 85W-140
SHELL	Omala 460
SUN	Sunep 1110

THIRD Preference Group (Natural Petroleum Base):

AMOCO	Perma Gear EP140
ARCO	Pennant NL 460
CONOCO	EP 460
EXXON	Spartan EP 460
PHILLIPS	AP 140
TEXACO	Meropa 460
UNION	MP 85W-140
VALVOLINE	Gear Lub 85W-140

SCHAEFFER 268 Lubricant is available from J&M in five gallon cans. See SECTION VIII ORDERING PARTS.

G. CAPACITIES

- | | | |
|---------------------------------|---------|---------------------------------------|
| 1. Diesel Engine Crankcase | 6 or 10 | Quarts there are 2 different oil pans |
| 2. Hydraulic System (Reservoir) | 55 | Gallons |
| 3. Vibration Case | 0.5 | Gallons |
| 4. Fuel Tank Sub-Base (Diesel) | 28 | Gallons |
| 5. Engine Cooling System | 6 | Quarts |



**MODEL 23
VIBRATORY
DRIVER/EXTRACTOR**

**OPERATING
INSTRUCTIONS**

IV. MAINTENANCE AND ADJUSTMENTS

H. DRAINING AND FILLING HYDRAULIC FLUID RESERVOIR

1. The Hydraulic reservoir is drained by removing the plug on the side the reservoir.
2. The hydraulic reservoir is filled by pouring or pumping oil into the filler cap housing on the top of the reservoir. There is a strainer screen to insure no dirt enters the hydraulic system be cautious not to pour faster than the strainer can handle.

I. CHANGING HYDRAULIC RETURN FILTER ELEMENT

1. The return filter is located on the hydraulic reservoir next to the sight gauge.
2. To remove the return filter element, you must use a filter wrench capable of accepting a 5" (13 cm) diameter filter. Unscrew the return filter element counterclockwise to remove. Be sure the gasket is removed from the filter housing.
3. Clean filter housing with a clean lint free rag.
4. Install new filter element with a new gasket that has a light coating of multi-purpose grease. Screw the filter element clockwise onto the filter housing until the gaskets make contact to the filter housing base.
5. Using the filter wrench, tighten the return filter element approximately 3/4 of a turn..
6. With new return filter element installed, start the power unit and run for approximately three minutes. CHECK FOR LEAKS.



**MODEL 23
VIBRATORY
DRIVER/EXTRACTOR**

**OPERATING
INSTRUCTIONS**

IV. MAINTENANCE AND ADJUSTMENTS

J. BOLT TORQUE INFORMATION

Torque, in foot-pounds, is determined by the length of the wrench handle (in feet) multiplied by the weight (or force in pounds) applied at the end of the handle. For example, if the wrench is one foot long and five pounds of force is applied at the end of the handle, the total torque applied would be five foot pounds. A six inch wrench would require ten pounds of force to obtain five foot pounds of torque.

The only way to actually tighten high strength bolts is with a torque wrench. Proper use of the torque wrench is important. To obtain the listed torques, a steady pull should be exerted to the handle until the desired torque is reached.

The following torque specifications apply to the bolts from the vibrator assemblies listed. Whenever any of these bolts, are replaced, the given torque specifications should be adhered to.

VIBRATION SUPPRESSOR

Page VIII-6

Item 5, 6, 44	1/2"-13	119 Ft-Lbs (16.4 Kg-M)
Item 9, 30, 33, 43	5/8"-11	233 Ft-Lbs (32.3 Kg-M)
Item 45	3/4"-10	417 Ft-Lbs (57.6 Kg-M)
Item 28	1"-8	1009 Ft-Lbs (139.4 Kg-M)

VIBRATION CASE

Page VIII-10

Item 13	3/8"-16	48 Ft-Lbs (6.6 Kg-M)
Item 14	1/2"-13	119 Ft-Lbs (16.4 Kg-M)

CLAMP CYLINDER

Page VIII-12

Item 10	1/2"-13	119 Ft-Lbs (16.4 Kg-M)
Item 11	1"-8	1009 Ft-Lbs (139.4 Kg-M)



**MODEL 23
VIBRATORY
DRIVER/EXTRACTOR**

**OPERATING
INSTRUCTIONS**

V. HYDRAULIC CIRCUITRY

A. HYDRAULIC CLAMP / VIBRATOR DRIVE

With the diesel engine running, hydraulic fluid is taken from the reservoir by the pump. The pump flow returns to the reservoir if the switch on the pendant has not been moved. Returning fluid is cooled by the HEAT EXCHANGER (HE) and filtered by the RETURN FILTER (F-1).

Turning the switch on the control pendant to FWD activates the CONTROL VALVE (V-1). Hydraulic fluid is directed to the CLOSE CLAMP side of the hydraulic CYLINDER (CYL) in the hydraulic clamp, because CHECK VALVE (CV-2) blocks the port connecting to the return side of the hydraulic motor. The clamp closes. Clamping pressure is indicated by the CLOSE pressure gage (GA-2). When clamping pressure reaches approximately 2500 PSI (172 Bar), the CLAMP PRESSURE SWITCH (PS) activates the PRIORITY VALVE (PV), which directs the flow from the clamp cylinder to the VIBRATOR MOTOR (M). Full motor speed is reached within a few seconds and the motor drive pressure is indicated by SYSTEM - FORWARD pressure gage (GA-1). Maximum drive pressure is limited to approximately 2500 PSI (172 Bar) by the RELIEF VALVE (RV-1). Oil exiting VIBRATOR MOTOR (M) returns to the power unit. Case drain oil from the motor returns to the reservoir. Case drain pressure is limited to 50 PSI (3.4 Bar) by the CASE DRAIN RELIEF VALVE (RV-2). Oil returning to the power unit to the reservoir through HEAT EXCHANGER (HE) and RETURN FILTER (F-1).

Pressure at the clamp cylinder is maintained by the CLAMP CHECK VALVE (CV-1). If clamping pressure falls below 2200 PSI (152 Bar), the CLAMP PRESSURE SWITCH (PS) deactivates the PRIORITY VALVE (PV) to restore pressure. When pressure is restored to approximately 2500 PSI the process repeats activating and deactivating the entire time the switch is in the FWD position.

Returning the Vibrator Switch to the center position STOP de-energizes control valve (V1), and again allows pump flow to return to the reservoir without driving the vibrator. The vibration stops. Motor cavitation is prevented in the stopping operation by the CHECK VALVE (CV-4).

Turning the clamp switch on the control pendant to CLAMP OPEN activates the CONTROL VALVE (V-1). Hydraulic fluid is directed to the OPEN CLAMP side of the hydraulic cylinder. The pressure in the OPEN CLAMP line opens the CLAMP CHECK VALVE (CV-1). The clamp opens. Pressure in the OPEN CLAMP line is indicated by the System - Forward clamp pressure gage (GA-1).

The quick-disconnect couplers (QD1, QD2, and QD5) permit de-coupling of the drive and case drain hoses at the power unit.

The quick-disconnect couplers (QD3 & QD4) permit de-coupling of the clamp hoses at the power unit.



MODEL 23
VIBRATORY
DRIVER/EXTRACTOR

OPERATING INSTRUCTIONS

V. HYDRAULIC CIRCUITRY

B. OTHER

Returning fluid is filtered by the RETURN FILTER (F2). INDICATOR GAGE (GA5) shows condition of FILTER (F2).

The HEAT EXCHANGER (HE) cools the hydraulic fluid returning to the reservoir.



**MODEL 23
VIBRATORY
DRIVER/EXTRACTOR**

**OPERATING
INSTRUCTIONS**

V. HYDRAULIC CIRCUITRY

HYDRAULIC SCHEMATIC

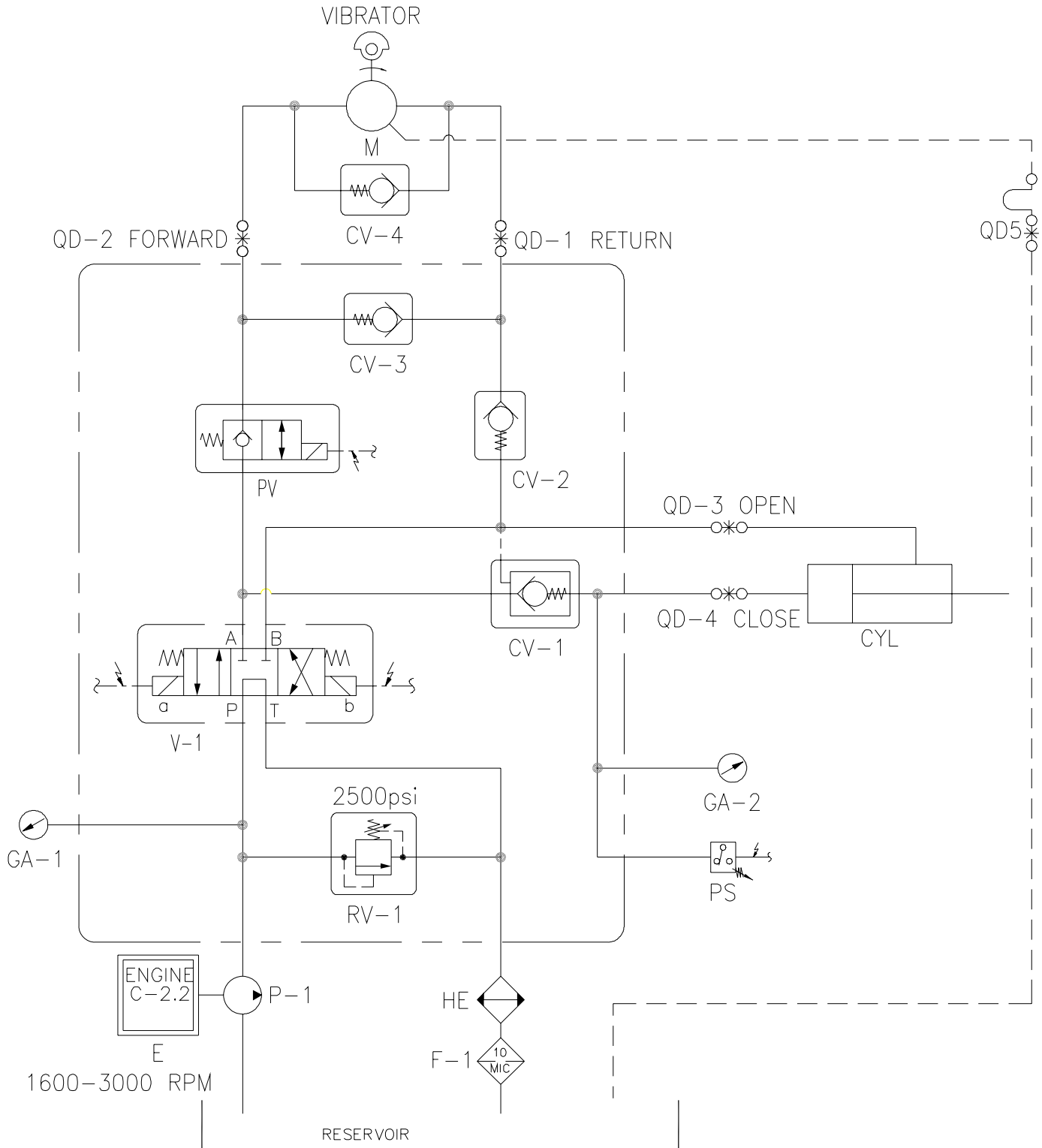



MODEL 23
VIBRATORY
DRIVER/EXTRACTOR

OPERATING
INSTRUCTIONS

V. HYDRAULIC CIRCUITRY

C. HYDRAULIC COMPONENTS LIST

<u>Notation</u>	<u>Description</u>	<u>Part Number</u>	<u>Page Number</u>
CV-1	Clamp Close Check Valve	300782	VIII-29
CV-2 & 3	Vibrator Check Valve	300770	VIII-29
CV-4	Vibrator Check Valve	110858	VIII-7
CYL	Hydraulic Clamp Cylinder	810941	VIII-12
E	Diesel Engine	300864	VIII-25
F-1	Return Filter Element	300842	VIII-25
GA-1	Pressure Gage System - Forward	300913	VIII-29
GA-2	Pressure Gage Close	300913	VIII-29
HE	Heat Exchanger	300866	VIII-25
M	Motor	130785	VIII-11
P-1	Drive Pump	300872	VIII-25
PS-1	Clamp Pressure Switch	810425	VIII-29
PV-1	Priority Valve	300762	VIII-29
QD1	Vibrator Return Disconnect	400251	VIII-26
QD2	Vibrator Forward Disconnect	400095	VIII-26
QD3	Clamp Open Disconnect	100777	VIII-26
QD4	Clamp Close Disconnect	100245	VIII-26
QD5	Case Drain Disconnect		VIII-26
RV-1	System Relief Valve	300784	VIII-29
V-1	Control Valve	300764	VIII-29



MODEL 23
VIBRATORY
DRIVER/EXTRACTOR

OPERATING INSTRUCTIONS



MODEL 23
VIBRATORY
DRIVER/EXTRACTOR

OPERATING INSTRUCTIONS

VI. ELECTRIC CIRCUITRY (REFERENCE:ELECTRICAL SCHEMATIC PG VI-4)

A. STARTING DIESEL ENGINE

The BATTERY provides 12-volt current to start the diesel engine. With the vibrator switch CLAMP OPEN - STOP - FOR on the control pendant should be in the STOP position. Hold SHUTDOWN RESET button in and turn the ENGINE START switch to the HEAT position. Hold there for 6 seconds until the glow plug indicator light illuminates. While the glow plug indicator is illuminated, turn the engine start switch to the START position this energizes the STARTER MOTOR and turns over the diesel engine. If fuel is available, the diesel engine will start. If the engine fails to start after 30 seconds of cranking, allow the starter to cool for two minutes before repeating the starting procedure. The HOUR METER indicates engine operating hours.

B. STOPPING DIESEL ENGINE

Turning the ENGINE START switch to OFF shuts off the fuel supply to the diesel engine. The engine stops.

C. SAFETY CONTROL SYSTEM

INFORMATION

A system of safety controls shut off the fuel supply, which stops the diesel engine in the event that engine water temperature is too high or engine oil pressure is too low.

The heart of the safety system is the shutdown reset, which is normally closed, thereby providing current to operate the HOUR METER and to energize the FUEL SOLENOID. Energizing the fuel solenoid opens the injector pump and allows fuel to flow to the diesel engine. The shutdown reset must remain closed so that fuel continues to flow to the diesel engine.

If the coil in the shutdown reset is energized, the shutdown reset will open, shutting off the fuel to the diesel engine. The engine will stop. The coil may be energized by either of the following devices:

1. ENGINE OIL PRESSURE - If oil pressure is below 15 PSI (1 Bar), contacts in the gage will be closed providing current to energize the shutdown reset coil. On start-up, the reset button of the shutdown reset (on the control panel) must be held in until oil pressure exceeds 30 PSI.
2. ENGINE WATER TEMPERATURE - If water temperature exceeds 210°F(99°C), the contacts of the gage will close energizing the shutdown reset coil.



MODEL 23
VIBRATORY
DRIVER/EXTRACTOR

OPERATING INSTRUCTIONS



**MODEL 23
VIBRATORY
DRIVER/EXTRACTOR**

**OPERATING
INSTRUCTIONS**

VI. ELECTRICAL CIRCUITRY

D. CLOSING CLAMP / STARTING VIBRATOR

With the diesel engine running, turning the switch on the control pendant to FWD energizes the fwd - close solenoid (FWD - CLOSE). This operates the control hydraulic valve and closes the clamp. When clamping pressure reaches approximately 2500 PSI (172 Bar), the CLAMP PRESSURE SWITCH (PS) activates the PRIORITY VALVE (PV), which directs the flow from the clamp cylinder to the hydraulic motor and the vibrator starts. If clamping pressure falls below 2200 PSI (152 Bar), the CLAMP PRESSURE SWITCH (PS) deactivates the PRIORITY VALVE (PV) to restore pressure. When pressure is restored to approximately 2500 PSI the process repeats activating and deactivating the entire time the switch is in the FWD position.

E. STOPPING VIBRATOR

With the diesel engine running, turning the switch on the control pendant to the STOP position de-energizes the fwd - close solenoid. Fluid no longer is directed to the motor and the vibration stops.

Turning the clamp switch on the control pendant to CLAMP OPEN activates the CONTROL VALVE (V-1). Hydraulic fluid is directed to the OPEN CLAMP side of the hydraulic cylinder. The pressure in the OPEN CLAMP line opens the CLAMP CHECK VALVE (CV-1). The clamp opens. Pressure in the OPEN CLAMP line is indicated by the System - Forward clamp pressure gage (GA-1).

F. OPENING HYDRAULIC CLAMP

With the diesel engine running, turning the switch to OPEN energizes the clamp open solenoid (CLAMP OPEN). The clamp opens.

G. OTHER

The Hour meter(M-1) indicates the engine operating hours.



MODEL 23 VIBRATORY DRIVER/EXTRACTOR

OPERATING INSTRUCTIONS

VI. ELECTRICAL CIRCUITRY

ELECTRICAL SCHEMATIC

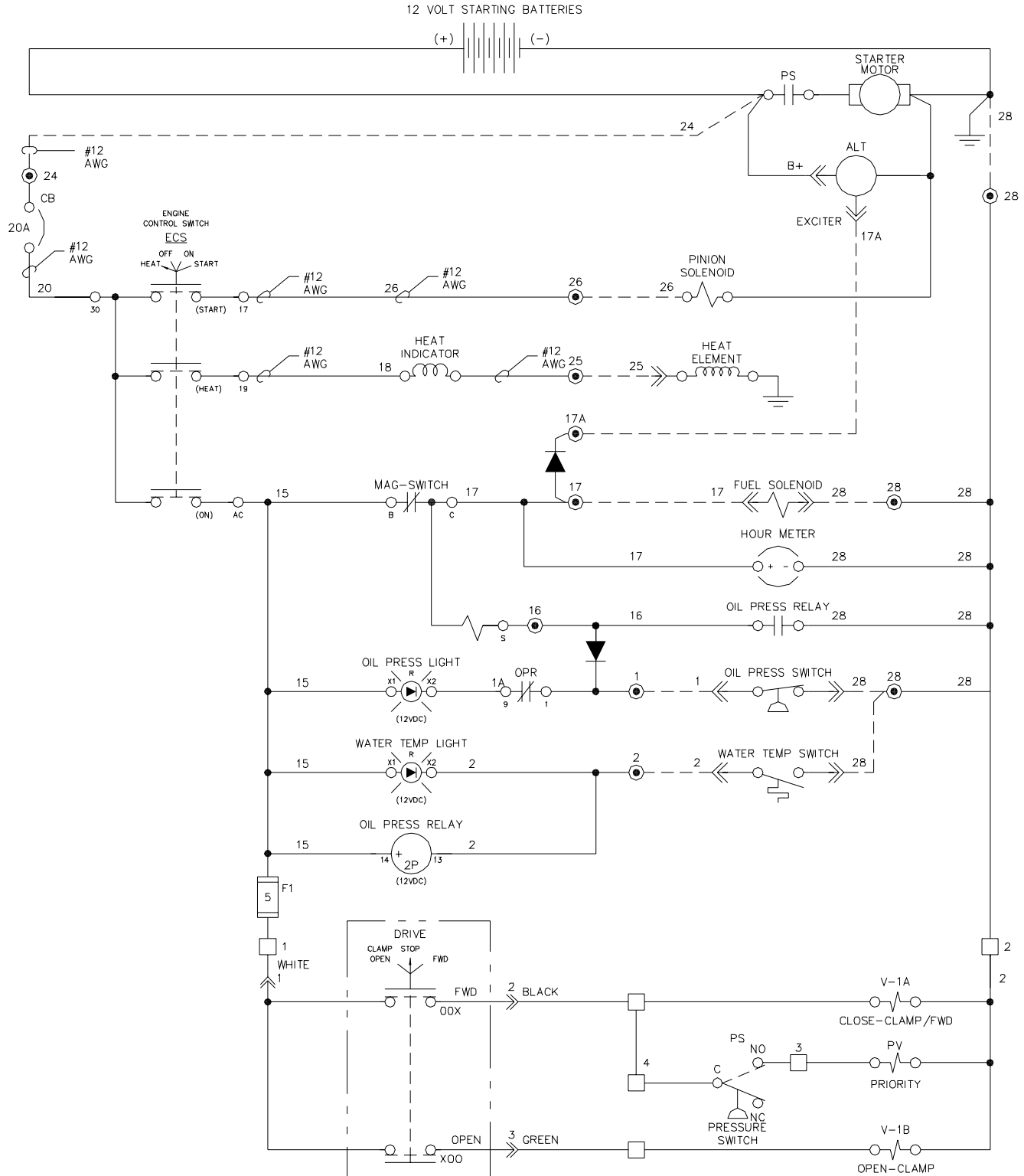



MODEL 23
VIBRATORY
DRIVER/EXTRACTOR

OPERATING
INSTRUCTIONS

VI. ELECTRICAL CIRCUITRY

H. ELECTRICAL COMPONENTS LIST

<u>Notation</u>	<u>Reference</u>	<u>Part Number</u>	<u>Page Number</u>
ALT	Alternator	See Cat. Parts Book	
BATTERY	12-Volt Battery	300575	VIII-25
CB	Main Power Circuit Breaker	130257	VIII-19
DRIVE	Vibrator Switch (CLAMP OPEN/STOP/FWD)	170841	VIII-21
ENG. START SW.	Engine Start Switch	See Cat. Parts Book	
ENG. START SW.	Engine Start Switch	See Cat. Parts Book	
FUEL SOLENOID	Fuel Solenoid	See Cat. Parts Book	
OIL PRESS LIGHT	Engine Oil Pressure Light	170875	VIII-19
OIL PRESS RELAY	Engine Oil Pressure Relay	300758	VIII-19
OIL PRESS SWITCH	Engine Oil Pressure Switch	See Cat. Parts Book	
WATER TEMP LIGHT	High Engine Water Temperature Light	170875	VIII-19
WATER TEMP SWITCH	High Engine Water Temperature Switch	See Cat. Parts Book	
MAG SWITCH	Shutdown Reset	130257	VIII-19
PS-1	Pressure Switch	810257	VIII-29
PV	Priority Solenoid (Valve)	300762	VIII-29
STARTER MOTOR	Engine Starter Motor	See Cat. Parts Book	
V-1A	Close-Clamp / Forward Solenoid (Valve)	300764	VIII-29
V-1B	Open-Clamp Solenoid (Valve)	300764	VIII-29



MODEL 23
VIBRATORY
DRIVER/EXTRACTOR

OPERATING INSTRUCTIONS



MODEL 23
VIBRATORY
DRIVER/EXTRACTOR

PARTS LIST

VII. GENERAL DATA

A. ABBREVIATIONS

The abbreviations shown below are used throughout the parts lists and various other parts of the manual.

ASM.	Assembly
BHCS	Button Head Cap Screw
Cyl.	Cylinder
DC	Direct Current
FHCS	Flat Head Cap Screw
FLCS	Flanged Head Cap Screw
HC	High Collar
HHCS	Hex Head Cap Screw
HHPP	Hex Head Pipe Plug
HSSS	Hex Socket Set Screw
Hyd.	Hydraulic
Lg.	Long
mm	Millimeter
Mtg.	Mounting
NPT.	National Pipe Thread
PHMS	Phillips Head Machine Screw
P/N	Part Number
Qty.	Quantity
RHMS	Round Head Machine Screw
Sch.	Schedule
SHCS	Socket Head Cap Screw
SHPP	Socket Head Pipe Plug
SHSS	Socket Head Shoulder Screw
S/N	Serial Number
Sol.	Solenoid

B. SCREWS AND BOLTS

1. Practically all connections on the unit are made with socket head (Allen) cap screws. These high-strength screws are available at most industrial supply houses.
2. Screws and bolts are designated in the PARTS LIST in abbreviated form. (Refer to sub-section A, above, for specific abbreviations.) Listed below is a typical screw description: 0.50 - 13 UNC X 1.50 LG SHCS

0.50 = Diameter 13 UNC = Threads Per Inch
1.50 LG = Length SHCS = Screw Type Abbreviation

3. Some screws or bolts require a specific torque when replacing. For identification of these bolts and a more thorough understanding of torque, refer to Page IV-9.



MODEL 23
VIBRATORY
DRIVER/EXTRACTOR

PARTS LIST

VII. GENERAL DATA

C. SERIAL NUMBER LOCATIONS

1. The following J&M vibratory units are serial numbered separately:
 - a. Vibrator
 - b. Power unit
2. In addition to the serial number plate itself (on vibrators, power units), the serial number is stamped into each unit in one or more places as follows:
 - a. Vibrator stamped twice - once on top right side of suppressor housing, once on bottom lip of vibration case on the of motor side.
 - b. Power unit stamped twice - once on the fuel tank near the filler tube, once on the reservoir in the "J" of the J&M logo.



MODEL 23
VIBRATORY
DRIVER/EXTRACTOR

PARTS LIST

VIII. ORDERING PARTS

A. PROCEDURE

1. When ordering parts, **be sure to include the model and serial number** of the unit or component. The serial number may be located by referring to SECTION VII, SERIAL NUMBER LOCATION. Confirm all telephone orders immediately to avoid duplicating shipment.
2. ORIGINAL EQUIPMENT; Where component serial numbers are given, these apply only to equipment and components originally furnished with the unit. Where equipment has been changed or upgraded these numbers may not be an adequate description.
3. SHIPMENT; State to whom shipment is to be made and method of shipment desired, otherwise our own judgement will be used.
4. SHORTAGES; Claims for shortages or errors should be made immediately upon receipt of parts. No responsibility will be assumed for delay, damage or loss of material while in transit. Broken, damaged or lost material should be refused or a full description made of damage or loss to the carrier agent on the freight or express bill.
5. RETURN OF PARTS; If for any reason you desire to return parts to the factory or to any distributor from whom these parts were obtained, you must first secure permission to return the parts. Shipping instructions will be given along with this permission. A ten percent handling charge must be assessed against the returned shipment unless an error is made by the factory or by the distributor when filling your order.



**MODEL 23
VIBRATORY
DRIVER/EXTRACTOR**

PARTS LIST

VIII. ORDERING PARTS

B. FITTING DESCRIPTION KEY

FITT 2 L - 16 M 12 J 00 0 - 00L 0 0 0 1

SELECTOR INDEX

- 2 - INCH FITTING
- 9 - METRIC FITTING

CONFIGURATION OR
SHAPE OF FITTING

- S - STRAIGHT FITTING
- L - 90 Deg. ELBOW
- V - 45 Deg. ELBOW
- T - TEE
- C - CAP
- P - PLUG
- U - UNION
- X - CROSS

(FOURTH END FITT'G REQ'D.)

FIRST END SIZE

- * IN 1/16THS OF AN INCH
(INDEX 2)
- IN MILLIMETERS (INDEX 9)
- SEE GENERAL SPECIFICATION
SHEET FOR SEQUENCE OF ORDER

FIRST END FITTING STYLE

- SEE FITTING STYLE SELECTOR
CHART SC-1

SECOND END SIZE

- IF APPLICABLE - SEE
FIRST END SIZE

SECOND END FITTING STYLE

- IF APPLICABLE - SEE
FIRST END FITTING STYLE

THIRD END SIZE

- IF APPLICABLE - SEE
FIRST END SIZE

THIRD END FITTING STYLE

- IF APPLICABLE - SEE
FIRST END SIZE

*** EXCEPTIONS**

- 90 = 10" 96 = 6"
- 92 = 12" 98 = 8"
- 94 = 14" 99 = NON CODE SIZE

MATERIAL

- 1 - CARBON STEEL
- 2 - BRASS
- 4 - STAINLESS STL
- 5 - AAR MAL IRON
- 6 - MALEABLE IRON
- 8 - FORGED STEEL

SPECIAL NOTATIONS

PRESSURE RATING

- 0 - NONE
- 1 - 125 LB.
- 3 - SCH 40
- 4 - SCH 80

INSTALLATION AID OR
STYLE OF HEAD

- 0 - NOT APPLICABLE
- H - REGULAR HEX
- Q - SQUARE HEAD (EXT.)
- R - SQUARE HEAD (INT.)
- S - HEX HEAD (INT SOCKET)
- T - HEX HEAD (EXT.)

LENGTH CODE

- (ELBOWS & NIPPLES)
- __L - LONG (ELBOW)
- __X - EXTRA LONG (ELBOW)
- __C - CLOSE (NIPPLE)

- PIPE NIPPLES (LONG) ONLY
IN DEC. INCHES FOR INDEX 2
- 050 = 5.0 INCHES
- 105 = 10.5 INCHES

- IN MILLIMETERS FOR INDEX 9
- 120 = 12.0 MILLIMETERS
- 084 = 8.4 MILLIMETERS

FOURTH END SIZE &
FITTING STYLE

- (CROSSES ONLY)
- SEE FIRST END FITTING SIZE OR
END STYLE



**MODEL 23
VIBRATORY
DRIVER/EXTRACTOR**

PARTS LIST

B. FITTING DESCRIPTION KEY (CONTINUED)

FITTING STYLE SELECTOR CHART

SC-1

FOR END FITTING STYLE SELECTION

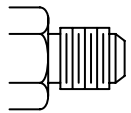
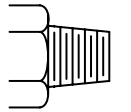
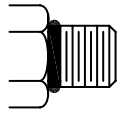
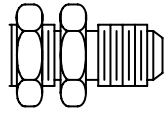
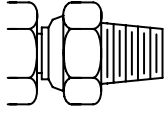
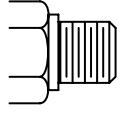
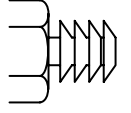
M		JIC MALE 37 Deg. FLARE
P		MALE PIPE NPT
R		S.A.E. MALE O-RING (& ADJUSTABLE)
B		JIC MALE 37 Deg. FLARE BULKHEAD
D		MALE PIPE NPT SWIVEL
S		B.S.P. MALE PIPE
T		HOSE BARB

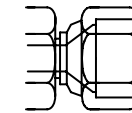
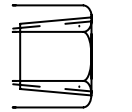
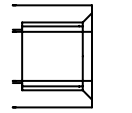
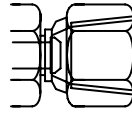
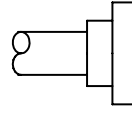
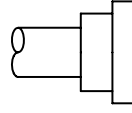
J		JIC FEMALE 37 Deg. FLARE (& SWIVEL)
Q		FEMALE PIPE NPTF
K		S.A.E. FEMALE O-RING
N		FEMALE PIPE NPSM-SWIVEL
F		SPLIT FLANGE 3000 PSI. CODE 61
H		SPLIT FLANGE 6000 PSI. CODE 62



**MODEL 23
VIBRATORY
DRIVER/EXTRACTOR**

PARTS LIST

VIII. ORDERING PARTS

C. HOSE DESCRIPTION CODE

The HOSE DESCRIPTION CODE is a 24 digit number enabling easier and quicker identification whenever a hose replacement is desired. The key below explains the structure of the coded number in detail.

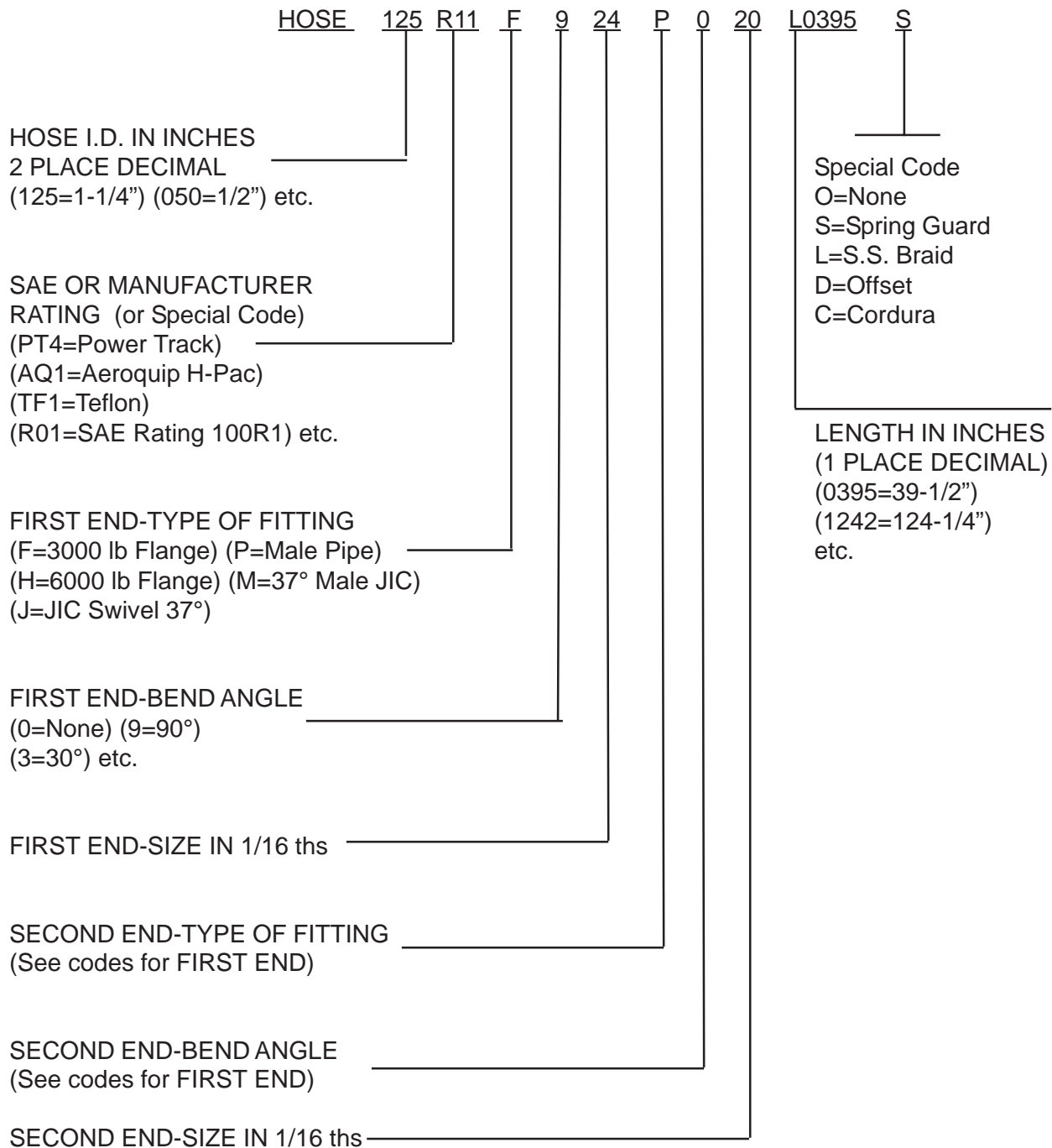



**MODEL 23
VIBRATORY
DRIVER/EXTRACTOR**

PARTS LIST

VIII. ORDERING PARTS

D. PARTS IDENTIFICATION

1. Parts lists and drawings are included on the following pages for the equipment components shown below:

a. VIBRATION SUPPRESSOR / WICK INSERTER	800603
b. VIBRATION CASE	810729
c. CLAMP CYLINDER	810941
d. HOSE ASSEMBLIES - INTERCONNECTING	800499
e. POWER UNIT ENCLOSURE	810943
f. CONTROL BOX	810939
g. CONTROL PENDANT	173061
h. POWER UNIT - INTERNAL	800587
i. CONTROL MANIFOLD	810888

2. The spare parts list SECTION VIII - RECOMMENDED SPARE PARTS contains spare parts which may be very useful in keeping down-time to a minimum, especially in remote or secluded job sites where unforeseen communication problems could cause delay of the delivery of an awaited part.

These RECOMMENDED SPARE PARTS may be ordered beforehand, individually or as a package group as shown in the PARTS LIST.



MODEL 23
VIBRATORY
DRIVER/EXTRACTOR

PARTS LIST

VIBRATION SUPPRESSOR / WICK INSERTER

800603

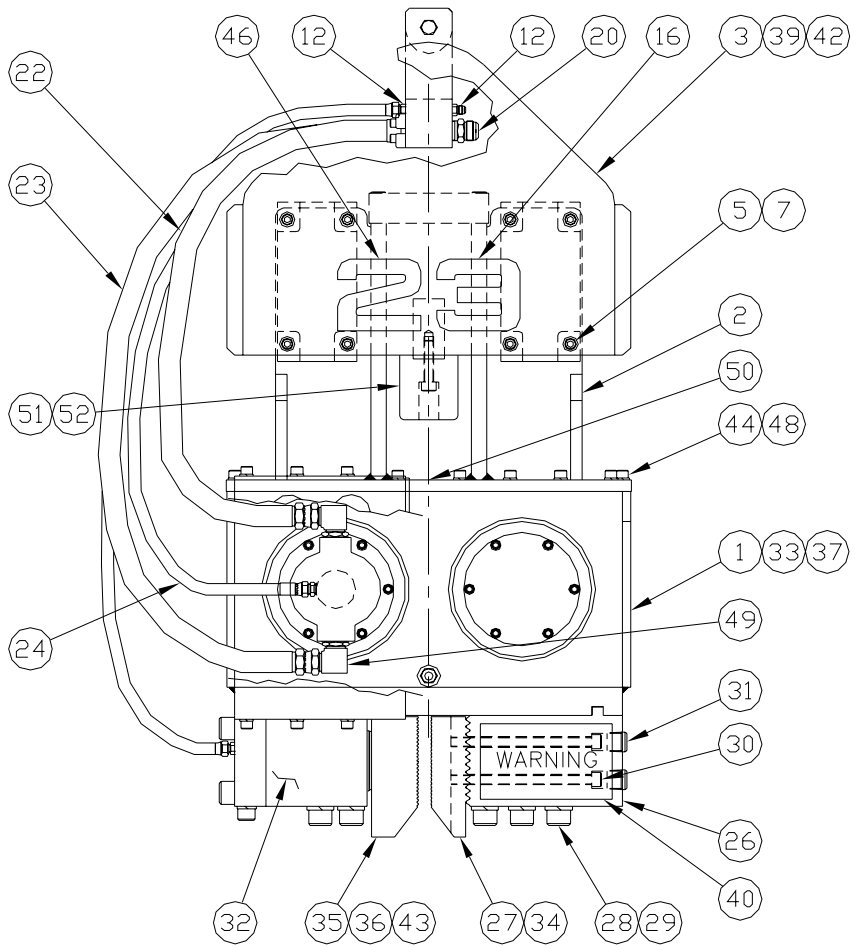
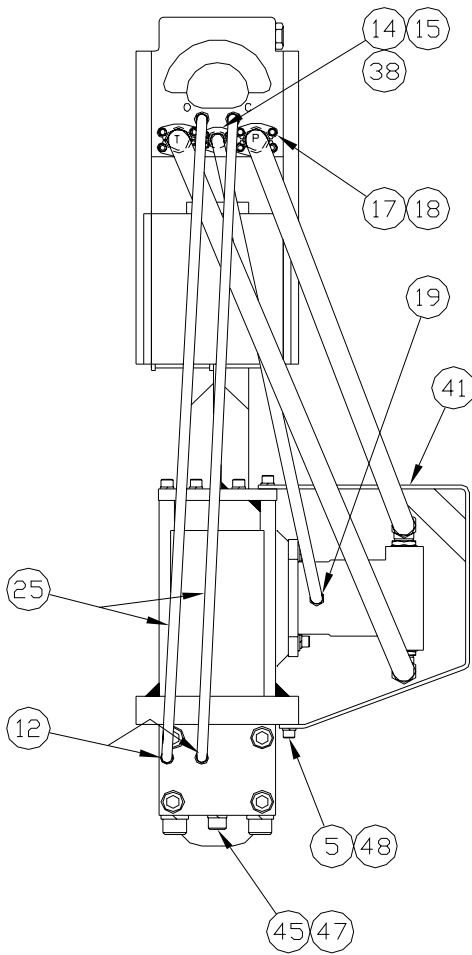
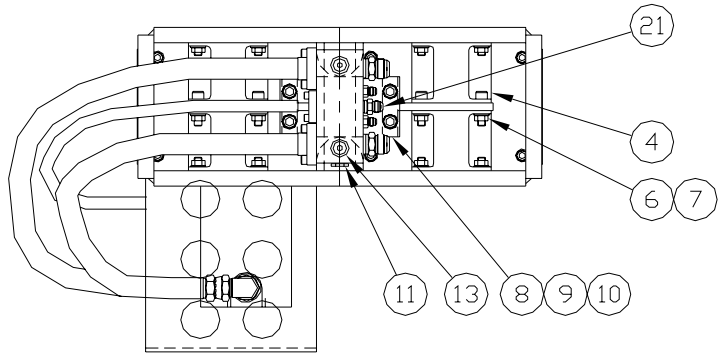



MODEL 23
VIBRATORY
DRIVER/EXTRACTOR

PARTS LIST

VIBRATION SUPPRESSOR / WICK INSERTER

800603

<u>Item</u>	<u>Part Number</u>	<u>Qty.</u>	<u>Description</u>
1	810729	1	MODEL 23 TRANS ASM
2	130914	1	TRANSMISSION ADAPTER
3	130649	1	SUPPRESSOR HOUSING
4	130685	4	ELASTOMER
5	100119	19	0.50-13 X 1.25 LG SHCS LOC WEL
6	100163	8	0.50-13 X 1.75 LG SHCS LOC WEL
7	130781	24	0.50-13UNC FLANGED NUT
8	130661	1	STOP BLOCK
9	400157	4	0.625-11 x 2.75 LG SHCS
10	130261	4	0.625 LOCKWASHER H C
11	110858	1	CHECK VALVE
12	100053	6	FITT2S-06M06R000-0000001
13	100903	2	FITT2P-08R000000-000S001
14	100103	2	#8 SPLIT FLANGE HALF
15	100105	4	0.312-18 X 1.0 LG SHCS LOC WEL
16	130875	2	SMALL # 3 LOGO
17	100089	4	#16 SPLIT FLANGE HALF
18	130117	8	0.375 X1.5 LG SHCS
19	100936	1	FITT2S-06M04R000-000H001
20	110823	2	FITT2S-16M16P000-000H001
21	110173	1	FITT2S-08M08P000-000H001
22		1	HOSE100R09F016J016L0550C
23		1	HOSE100R09F016J016L0700C
24		1	HOSE038R02J008J006L0600C
25		2	HOSE038R02J006J006L0700C
26	130673	1	FIXED JAW BRACKET
27	130675	1	FIXED JAW 5.00 WIDE
28	130695	10	1.00-8 7.50 LG SHCS
29	100209	10	1.00 LOCK WASHER MEDIUM
30	130697	2	0.625-11 X 9.00 LG SHCS
31	100063	2	FITT2P-16P000000-000S007
32	810941	1	CLAMP CYLINDER ASM
33	100299	1	PRIMER/GAL
34	130928	1	FIXED JAW 7.75 WIDE
35	130930	1	MOVABLE JAW 7.00 WIDE
36	130677	1	MOVABLE JAW 5.00 WIDE
37	100298	1	APE / J&M YELLOW PAINT/GAL
38	130973	1	FITT2S-08F08M000-000H001
39	130381	4	RIVET
40	130843	1	WARNING DECAL



MODEL 23
VIBRATORY
DRIVER/EXTRACTOR

PARTS LIST



MODEL 23
VIBRATORY
DRIVER/EXTRACTOR

PARTS LIST

VIBRATION SUPPRESSOR / WICK INSERTER

800603

<u>Item</u>	<u>Part Number</u>	<u>Qty.</u>	<u>Description</u>
41	130888	1	23 MOTOR GUARD
42	130885	1	23 SERIAL NUMBER PLATE
43	110411	2	0.625-11UNC X 1.5 LG. SHCS
44	100011	20	0.50-13 UNC X 2.00 LG SHCS
45	160349	1	0.75-10UNC X 7.50 LG SHCS
46	130867	2	SMALL # 2 LOGO
47	100069	1	0.75 LOCK WASHER MEDIUM
48	100121	23	0.50 LOCK WASHER MEDIUM
49	100783	2	FITT2L-16M16R000-000H001
50	100183	1	FITT2P-12P000000-000S007
51	130725	1	RECTAGULAR BUMPER
52	400157	2	0.625-11 UNC X 2.75 LG SHCS



MODEL 23
VIBRATORY
DRIVER/EXTRACTOR

PARTS LIST

VIBRATION CASE

810729

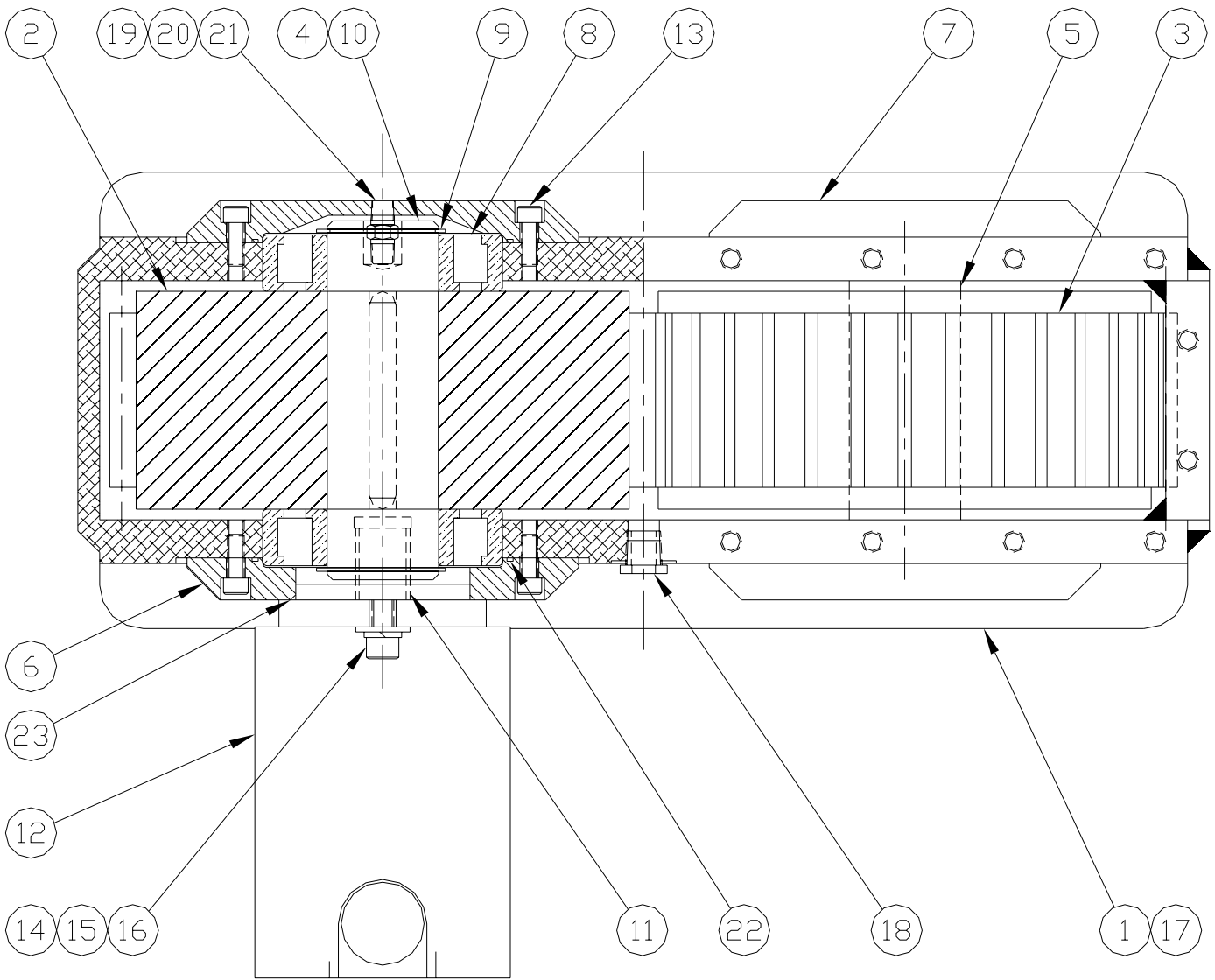



MODEL 23
VIBRATORY
DRIVER/EXTRACTOR

PARTS LIST

VIBRATION CASE

810729

<u>Item</u>	<u>Part Number</u>	<u>Qty.</u>	<u>Description</u>
1	810707	1	MODEL 23 TRANSMISSION CASE
2	130651	1	DRIVE GEAR
3	130663	1	IDLE GEAR
4	130653	1	MOTOR SHAFT
5	130655	1	IDLE SHAFT
6	130657	1	MOTOR COVER
7	130659	2	BEARING COVER
8	130689	4	BEARING
9	130691	4	SNAP RING
10	130665	1	KEY
11	130687	1	SPLINE ADAPTER
12	130785	1	DRIVE MOTOR
13	100051	24	.375-16 X 1.00 LG SHCS
14	100513	2	.5-13 X 1.5 LG SHCS
15	100483	2	.50 FLAT WASHER
16	100121	2	.50 LOCK WASHER MEDIUM
17	110444	0.5	TRANSMISSION OIL / GAL.
18	130605	1	SIGHT GAUGE
19	130783	1	BREATHER COVER
20	100662	1	FILTER
21	100822	1	BREATHER
22	130918	4	2-162 O-RING
23	130912	1	2-155 O-RING



MODEL 23
VIBRATORY
DRIVER/EXTRACTOR

PARTS LIST

CLAMP CYLINDER

810941

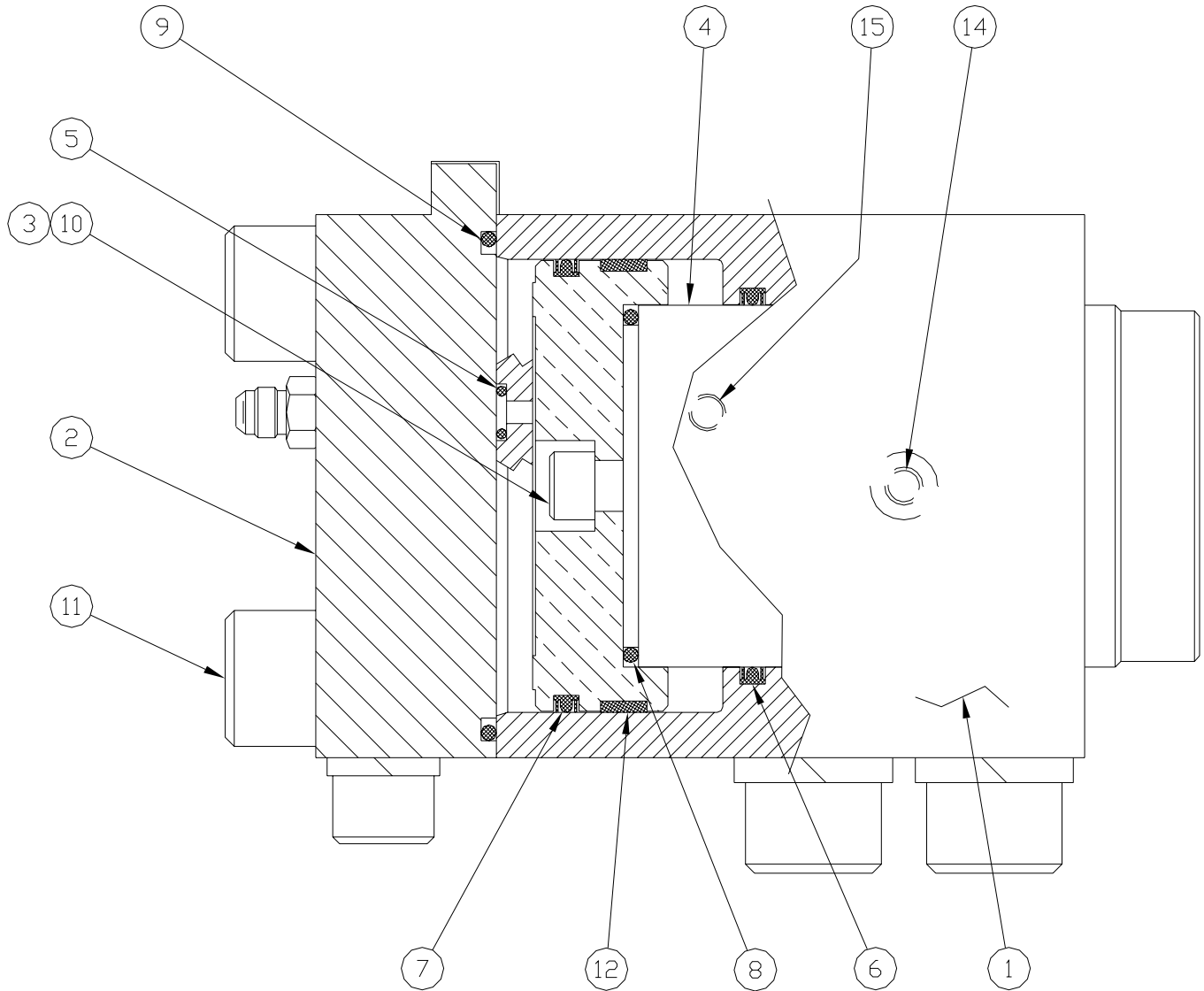



MODEL 23
VIBRATORY
DRIVER/EXTRACTOR

PARTS LIST

CLAMP CYLINDER

810941

<u>Item</u>	<u>Part Number</u>	<u>Qty.</u>	<u>Description</u>
1	130671	1	GUIDE BLOCK
2	130683	1	CYLINDER COVER
3	130681	1	PISTON
4	130679	1	CYLINDER ROD
5	130709	1	2-204 O-RING (NOTE)
6	130711	1	-43 T-SEAL ROD (NOTE)
7	130713	1	-47 T-SEAL PISTON (NOTE)
8	130715	1	2-342 O-RING (NOTE)
9	130717	1	2-355 O-RING (NOTE)
10	100011	3	0.50-13 UNC X 2.00 LG SHCS
11	140145	4	1.00-8 X 3.5 LG SHCS
12	130719	1	PISTON BEARING (NOTE)
13	810767	1	MODEL 23 CLAMP SEAL KIT
14	100229	1	GREASE FITTING
15	100646	1	FITT2P-000000-000S007

Note: Included in Model 23 Clamp Seal Kit 810767 Item 13



MODEL 23
VIBRATORY
DRIVER/EXTRACTOR

PARTS LIST

HOSE ASSEMBLIES - INTERCONNECTING

800499

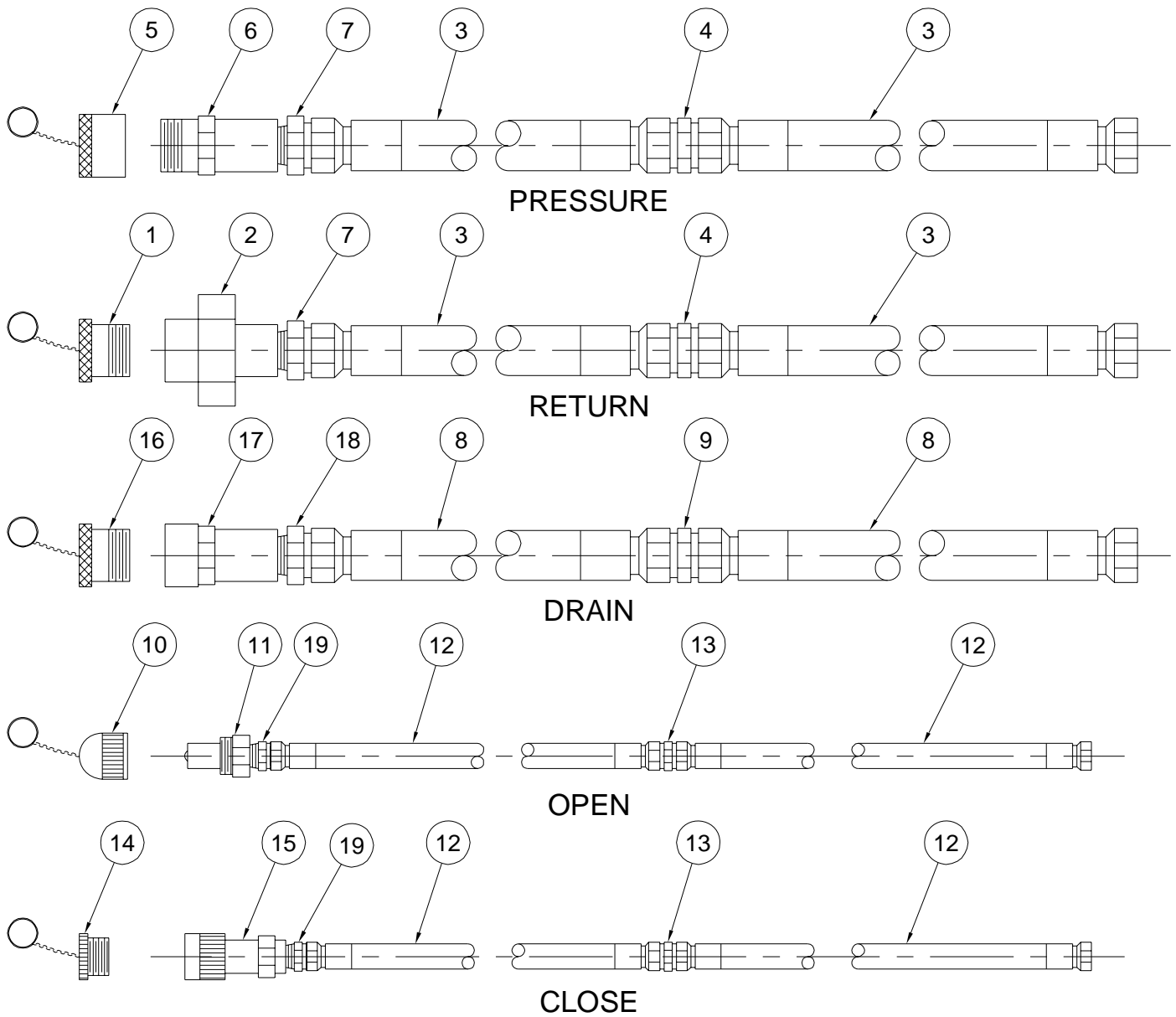



MODEL 23
VIBRATORY
DRIVER/EXTRACTOR

PARTS LIST

HOSE ASSEMBLIES

800499

<u>Item</u>	<u>Part Number</u>	<u>Qty.</u>	<u>Description</u>
1	400121	1	0.75 DUST PLUG
2	400095	1	0.75 FEMALE DISCONNECT
3	130787	4	HOSE100R02J016J016L60000
4	130789	2	FITT2S-16M16M000-000H001
5	400253	1	0.75 DUST CAP
6	400251	1	0.75 MALE DISCONNECT
7	140759	2	FITT2S-12P16M000-000H001
8	130791	2	HOSE050R01J008J008L62000
9	300403	1	FITT2S-08M08M000-000H001
10	100257	1	0.375 DUST CAP
11	100245	1	0.375 MALE DISCONNECT
12	130793	4	HOSE038R02J006J006L62000
13	120081	2	FITT2S-06M06M000-000H001
14	100737	1	0.375 DUST PLUG
15	100777	1	0.375 FEMALE DISCONNECT
16	130801	1	0.50 DUST PLUG
17	130799	1	0.50 FEMALE DISCONNECT
18	110173	1	FITT2S-08M08P000-000H001
19	400203	1	FITT2S-06M06P000-000H001
20	130243	10	RUBBER TIE DOWN



MODEL 23
VIBRATORY
DRIVER/EXTRACTOR

PARTS LIST

POWER UNIT ENCLOSURE

810943

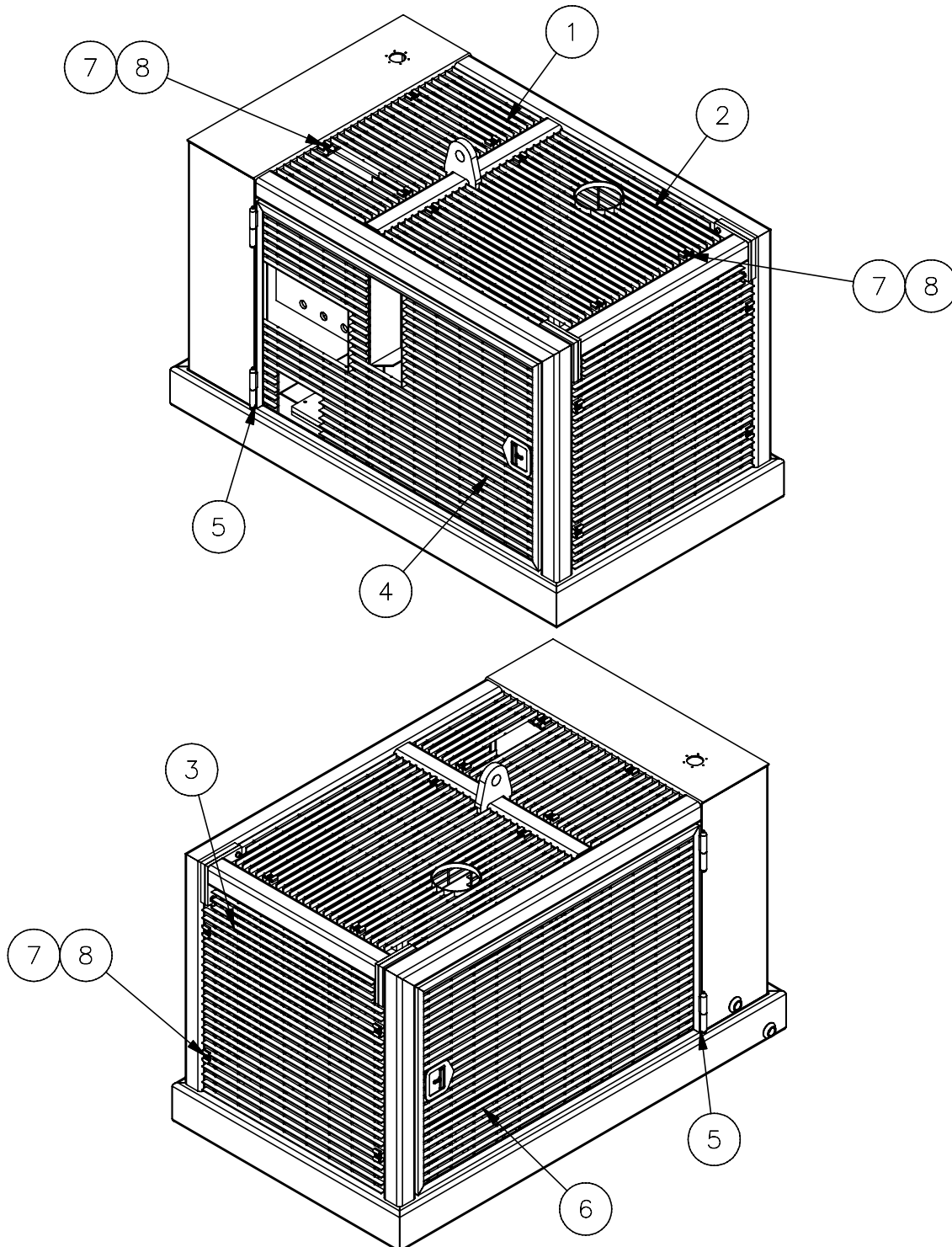



MODEL 23
VIBRATORY
DRIVER/EXTRACTOR

PARTS LIST

POWER UNIT ENCLOSURE

810943

<u>Item</u>	<u>Part Number</u>	<u>Qty.</u>	<u>Description</u>
1	300878	1	EXHAUST GRILL REAR
2	300880	1	EXHAUST GRILL TOP
3	300882	1	INTAKE GRILL FRONT
4	300876	1	RIGHT DOOR ASM
5	100232	4	BULLET HINGE ASM
6	300874	1	LEFT DOOR ASM
7	100398	12	SADDLE CLIP
8	110830	12	0.25 X 2.00 LG HEX TEX SCREW



MODEL 23
VIBRATORY
DRIVER/EXTRACTOR

PARTS LIST

CONTROL BOX

810939

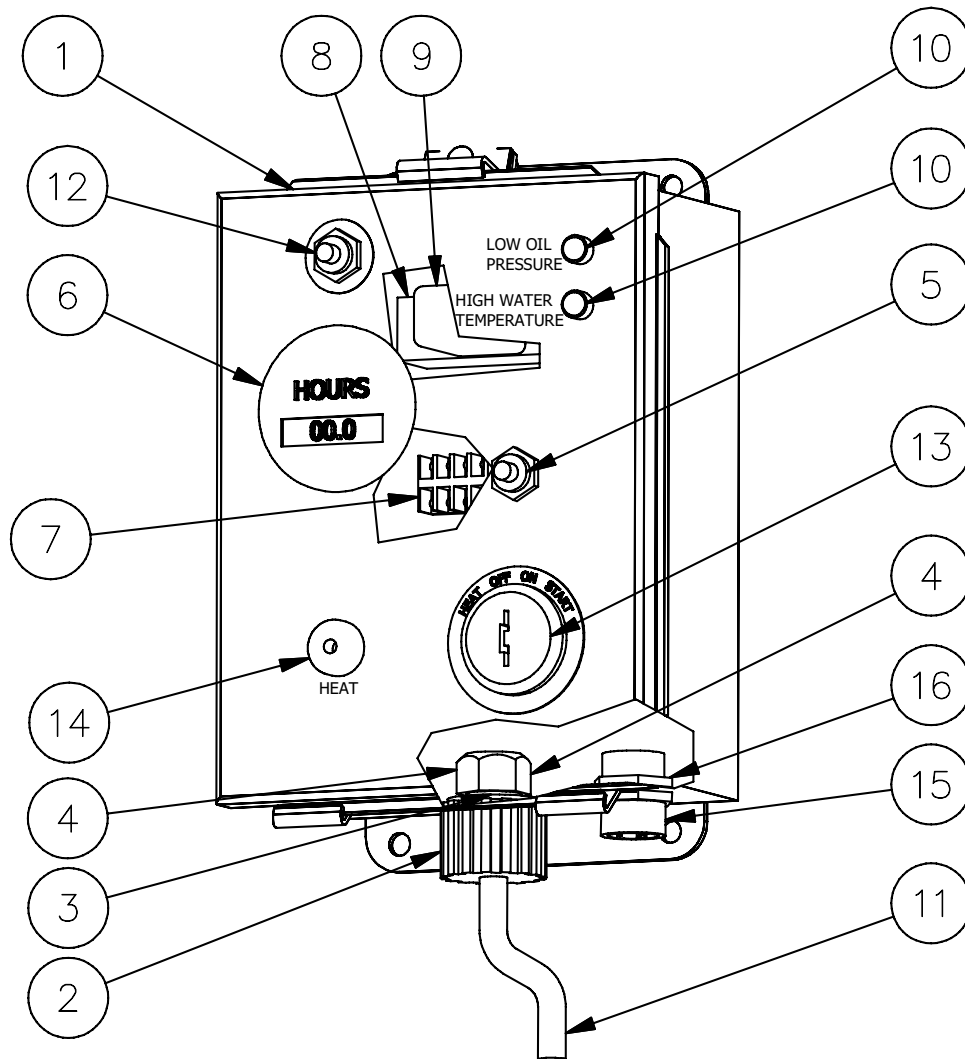



MODEL 23
VIBRATORY
DRIVER/EXTRACTOR

PARTS LIST

CONTROL BOX

810939

<u>Item</u>	<u>Part Number</u>	<u>Qty.</u>	<u>Description</u>
1	300814	1	CONTROL BOX
2	170869	1	0.75 CORD CONNECTOR
3	170867	1	RUBBER GASKET
4	170865	1	LOCK NUT
5	130257	1	MURPHY SWITCH
6	100343	1	HOUR METER
7	300760	1	10 POSITION TERMINAL BLOCK
8	300756	1	RELAY BASE
9	300758	1	RELAY
10	300754	2	RED L. E. D.
11	300752	1	6 FOOT WIRING HARNESS
12	300750	1	CIRCUIT BREAKER 20 AMP
13	300748	1	ENG KEY SWITCH
14	300746	1	GLOW PLUG INDICATOR
15	170849	1	S/O CORD RECEPTACLE
16	110843	1	0.50 LOCK NUT



MODEL 23
VIBRATORY
DRIVER/EXTRACTOR

PARTS LIST

PENDANT ASSEMBLY

173061

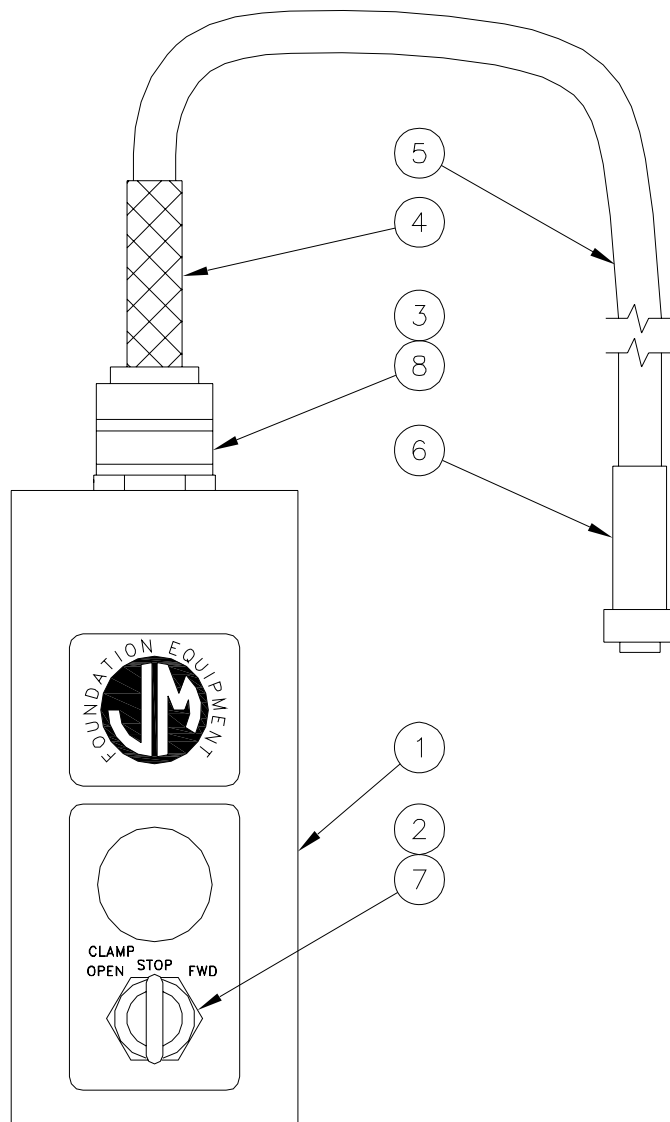



MODEL 23
VIBRATORY
DRIVER/EXTRACTOR

PARTS LIST

PENDANT ASSEMBLY

173061

<u>Item</u>	<u>Part Number</u>	<u>Qty.</u>	<u>Description</u>
1		1	Pendant Box
2	170841	1	Drive For/Rev Switch
3	170865	1	0.75 Lock Nut
4		1	Cord Grip Pendant End
5	100560	50	Pendant Cable
6		1	Pendant Receptacle
7	100413	1	Diode, 6 Amp
8	170867	1	0.75 Rubber Gasket
	170901	1	Contact Block 1 N.O. 1 N.C.



MODEL 23
VIBRATORY
DRIVER/EXTRACTOR

PARTS LIST

POWER UNIT - INTERNAL

800587

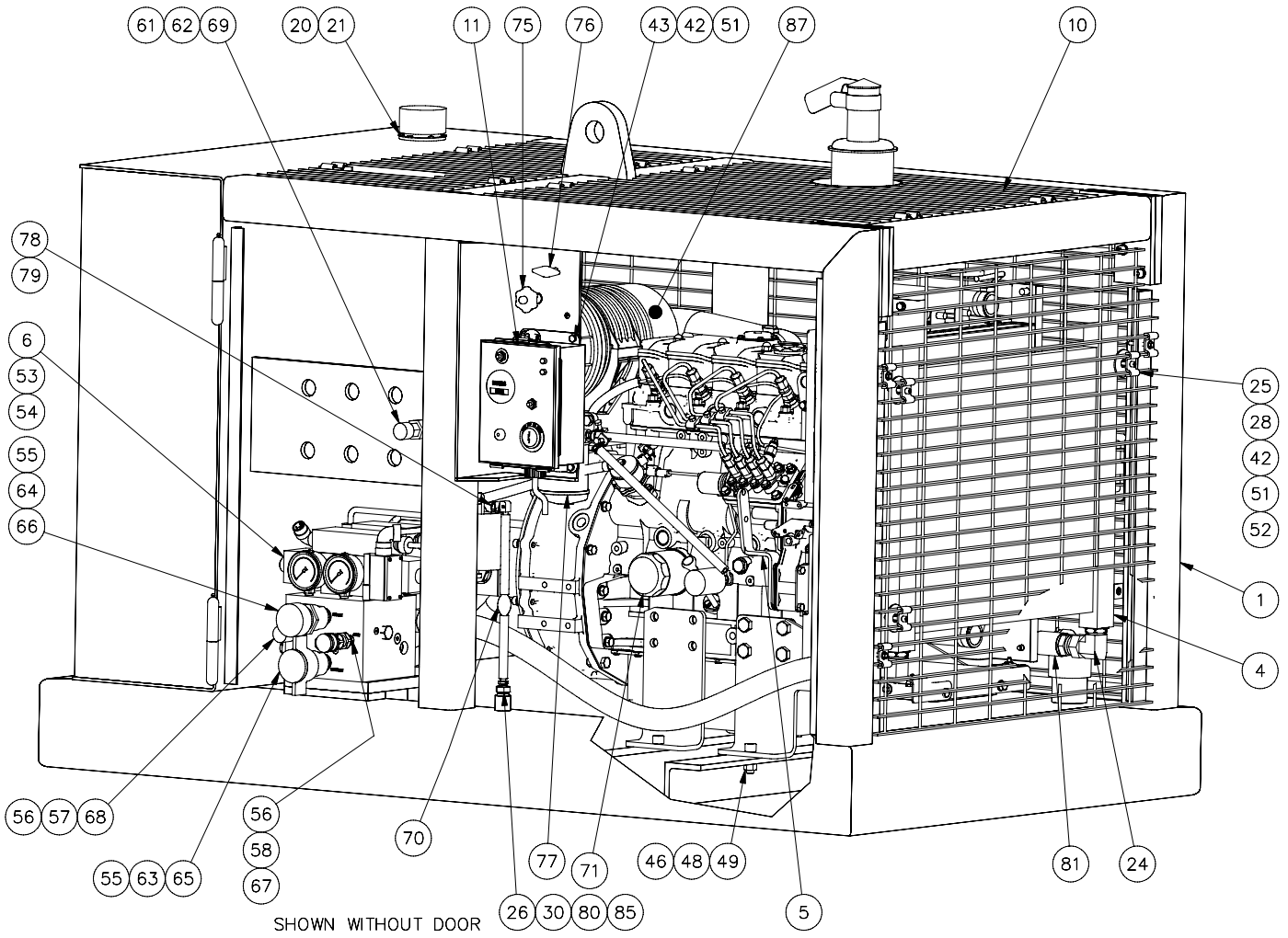



MODEL 23
VIBRATORY
DRIVER/EXTRACTOR

PARTS LIST

POWER UNIT - INTERNAL

800587

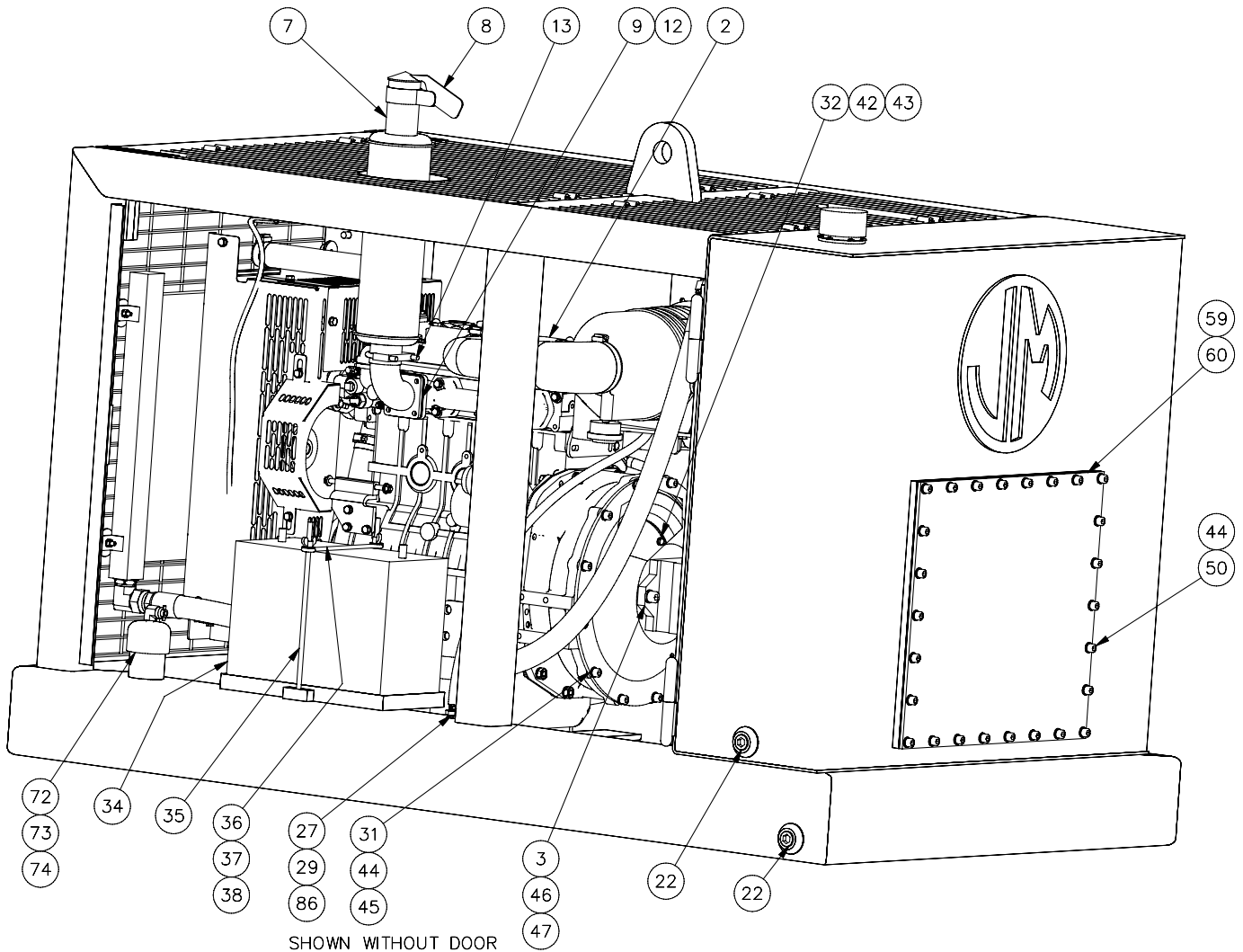



MODEL 23
VIBRATORY
DRIVER/EXTRACTOR

PARTS LIST

POWER UNIT - INTERNAL

800587

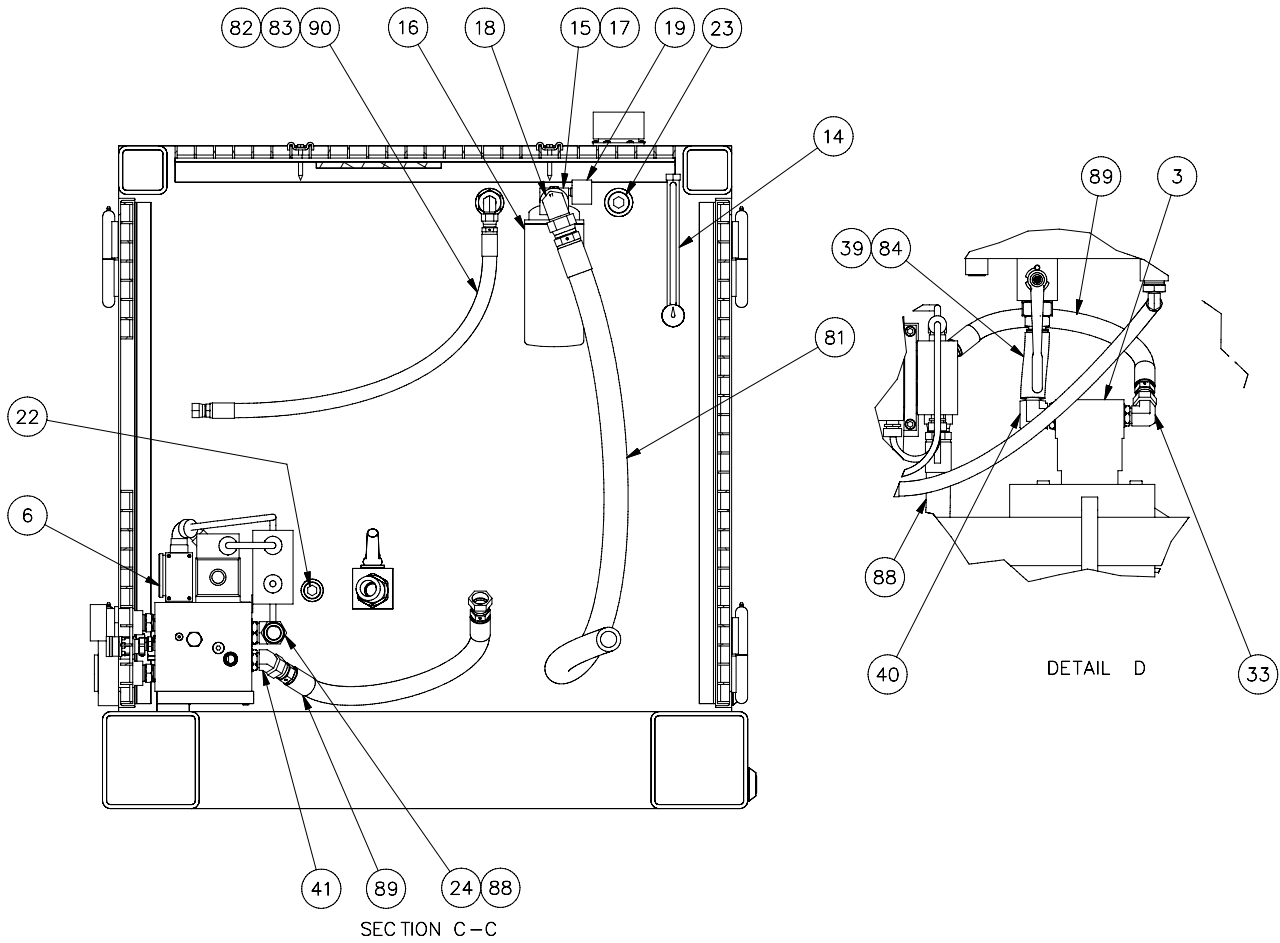



MODEL 23
VIBRATORY
DRIVER/EXTRACTOR

PARTS LIST

POWER UNIT - INTERNAL

800587

<u>Item</u>	<u>Part Number</u>	<u>Qty.</u>	<u>Description</u>
1	810907	1	51 HP SUB-BASE
2	300864	1	C 2.2 ENGINE
3	300872	1	PUMP
4	300866	1	HEAT EXCHANGER
5	300836	1	THROTTLE BRACKET
6	810888	1	23 VIBRO MANIF ASM
7	300774	1	MUFFER
8	300772	1	RAIN CAP 2"
9	300778	1	EXHAUST GASKET
10	810943	1	POWER UNIT ENCLOSURE
11	810939	1	CONTROL BOX ASM
12	300744	1	EXHAUST EXTENSION
13	300742	1	2 INCH MUFFLER CLAMP
14	130179	1	SIGHT GAGE
15	300844	1	RETURN FILTER HOUSING
16	300842	1	RETURN FILTER ELEMENT
17	100449	1	FITT2S-16P16P
18	120055	1	FITT2L-16M16P
19	100436	1	RETURN FILTER GAGE
20	170411	1	FILLER BREATHER ASM
21	110861	6	10-32UNF X 0.50 LG PHMS
22	100183	3	FITT2P-12P
23	100063	1	FITT2P-16P
24	100783	3	FITT2L-16M16R000-0000001
25	100398	4	SADDLE CLIP
26	100189	1	FITT2S-08P04Q
27	300740	1	FITT2S-06P02Q
28	300734	4	0.50 FLAT WASHER EXTRA
29	300738	1	FITT2S-03T02P
30	300736	1	FITT2S-05T04P
31	300732	1	PUMP ADAPTER
32	300730	1	FLEX PLATE ASM
33	100590	1	FITT2L-12M12R
34	300575	1	BATTERY 27 HD
35	400231	2	HOLD DOWN STUD
36	300077	1	BATTERY HOLD DOWN
37	100293	2	0.31 FLAT WASHER
38	100831	2	0.31 WING NUT
39	300728	1	FITT2S-16R16T
40	300726	1	FITT2L-16R16T000-0000001



MODEL 23
VIBRATORY
DRIVER/EXTRACTOR

PARTS LIST

POWER UNIT - INTERNAL

800587

<u>Item</u>	<u>Part Number</u>	<u>Qty.</u>	<u>Description</u>
41	300101	1	FITT2V-12M12R
42	100559	16	0.25 LOCK WASHER
43	300682	12	0.25-20UNC X 0.63 LG HHCS
44	400149	38	0.38 LOCK WASHER
45	100051	12	0.38-16UNC X 1.00 LG SHCS
46	100121	6	0.50 LOCK WASHER
47	100445	2	0.50-13UNC X 1.00 SHCS
48	100513	4	0.50-13UNC X 1.50 LG SHCS
49	100485	4	0.50-13UNC HEX NUT
50	300680	26	0.38-16UNC X 0.75 LG SHCS
51	100598	8	0.25-20UNC HEXT NUT
52	100595	4	0.25-20UNC X 1.25 SHCS
53	130767	3	0.38 HI COLLAR LOCK WASHER
54	100878	3	0.38-16UNC X 6.00 LG SHCS
55	120049	2	FITT2S-12P12P
56	110794	2	FITT2S-06P06P
57	100245	1	0.38 MALE DISCONNECT
58	100777	1	0.38 FEMALE DISCONNECT
59	300846	1	16 X 19 CLEANOUT GASKET
60	300906	1	RESERVOIR COVER
61	300708	1	FITT2S-08B08P
62	130795	1	0.50 MALE DISCONNECT
63	400095	1	0.75 FEMALE DISCONNECT
64	400251	1	0.75 MALE DISCONNECT
65	400121	1	0.75 DUST PLUG
66	400253	1	0.75 DUST CAP
67	100737	1	0.38 DUST PLUG
68	100257	1	0.38 DUST CAP
69	130797	1	0.50 DUST CAP
70	300664	1	FUEL BULB
71	300706	1	OIL FILTER
72	300700	1	FITT2C-32Q
73	300197	1	FITT2L-04P04Q
74	100419	1	PET COCK
75	300901	1	ENGINE THROTTLE
76	100345	1	ENGINE SHUT DOWN
77	300702	1	FUEL FILTER ELEMENT
78	300694	1	FUEL H2O SEPERATOR ASM
79	300692	1	FUEL H2O SEPERATOR ELEMENT



MODEL 23
VIBRATORY
DRIVER/EXTRACTOR

PARTS LIST

POWER UNIT - INTERNAL

800587

<u>Item</u>	<u>Part Number</u>	<u>Qty.</u>	<u>Description</u>
80	300690	2	FITT2L-04P05T
81	300684	1	HOSE100R02J016J016L05650
82	110706	1	FITT2S-16P08Q
83	300063	1	FITT2L-08M08P
84	300677	1	HOSE100R02 X 4.50 LG
85	300678	1	0.31 FUEL HOSE
86	300907	1	0.25 FUEL HOSE
87	300704	1	AIR FILTER ELEMENT
88	300688	1	HOSE100R02J016J016L03800
89	300696	1	HOSE075R02J012J012L01650
90	300686	1	HOSE050R01J008J008L03170



MODEL 23
VIBRATORY
DRIVER/EXTRACTOR

PARTS LIST

CONTROL MANIFOLD ASSEMBLY

810888

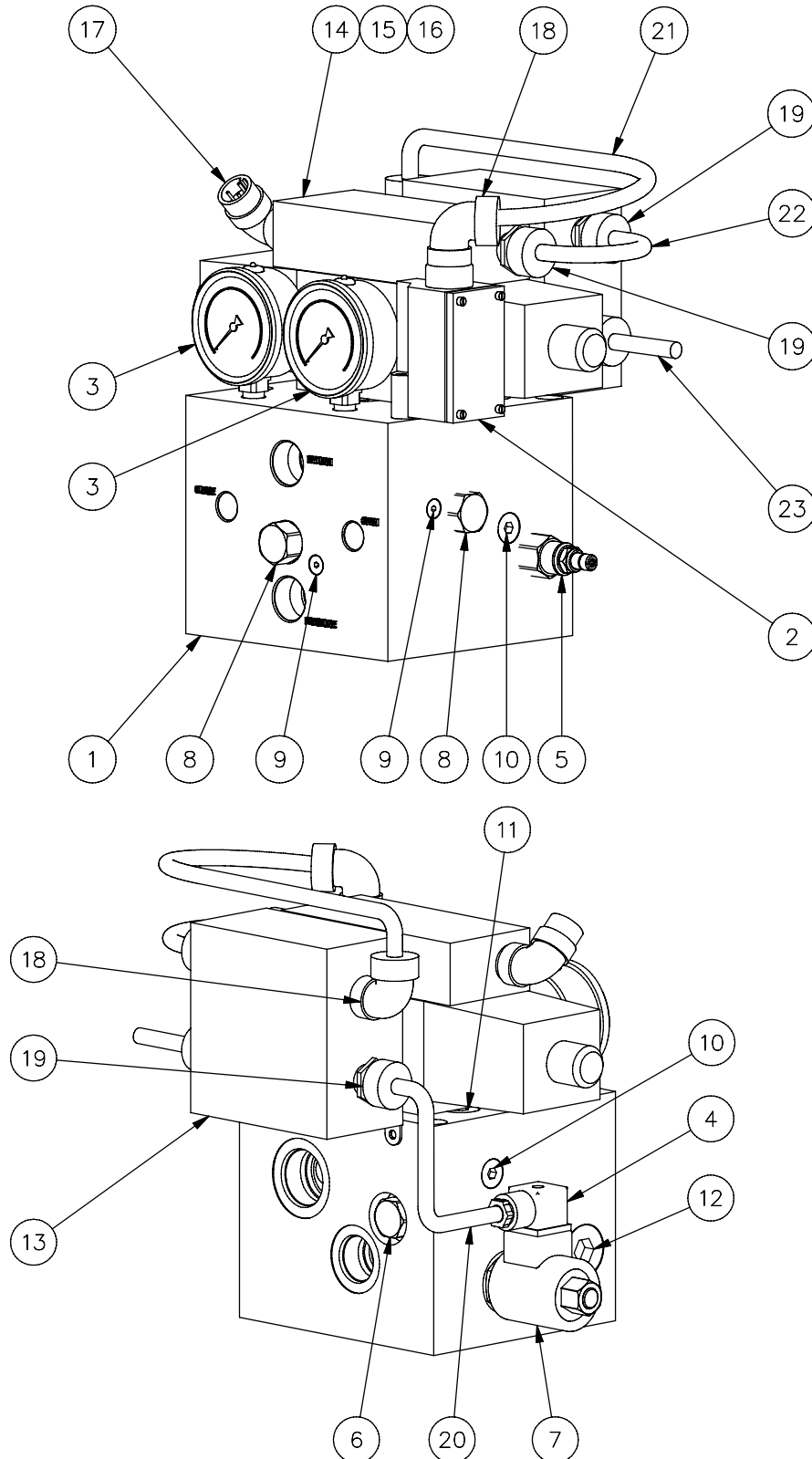



MODEL 23
VIBRATORY
DRIVER/EXTRACTOR

PARTS LIST

CONTROL MANIFOLD ASSEMBLY

810888

<u>Item</u>	<u>Part Number</u>	<u>Qty.</u>	<u>Description</u>
1	300786	1	MANIFOLD
2	810425	1	PRESSURE SWITCH
3	300913	2	GAGE 0-3000 PSI
4	120897	1	DIN CONNECTOR
5	300784	1	RELIEF VALVE
6	300782	1	PO CHECK VALVE
7	300762	1	SOLENOID VALVE
8	300770	2	CHECK VALVE
9	300716	2	FITT2P-2R
10	400992	2	FITT2P-06R
11	100903	3	FITT2P-08R
12	110248	1	FITT2P-12R
13	300714	1	ELEC ENCLOSURE
14	300764	1	CONTROL VALVE
15	100559	4	0.25 LOCK WASHER
16	300710	4	0.25-20UNC X 1.50 LG SHCS
17	170849	1	S/O CORD RECEPTACLE
18	100853	2	90 DEG S/O COMP FITTING
19	100855	4	STRAIGHT S/O COMP FITT
20		1	SO CORD FOR SOL VLV
21		1	SO CORD FOR PRESS SW
22		1	SO CORD FOR CONTR VLV
23		1	SO CORD TO CONTROL PANEL



MODEL 23
VIBRATORY
DRIVER/EXTRACTOR

PARTS LIST

VIII. ORDERING PARTS

E. MISCELLANEOUS ACCESSORIES

1. Bulk

<u>P/N</u>	<u>Qty.</u>	<u>Description</u>
810013	5 GAL	Hydraulic Fluid
110444	1 GAL	Vibration Case Lubricant
100726	1 GAL	Coolant/Anti-Freeze
100298	1 GAL	APE / J&M Yellow Paint
100299	1 GAL	Primer

F. RECOMMENDED SPARE PARTS

VIBRATION SUPPRESSOR

800603 Refer to page VIII-6

<u>Item</u>	<u>P/N</u>	<u>Qty.</u>	<u>Description</u>
4	130685	2 or 4	Elastomer
28	130695	10	1.00-8 7.50 LG SHCS
30	130697	2	0.625-11 X 9.00 LG SHCS
43	110411	2	0.625-11UNC X 1.5 LG. SHCS
45	160349	1	0.75-10UNC X 7.50 LG SHCS

VIBRATION CASE

810729 Refer to page VIII-10

<u>Item</u>	<u>P/N</u>	<u>Qty.</u>	<u>Description</u>
18	130605	1	Sight Gage
20	100662	1	Filter

MODEL 23 CLAMP CYL

810941 Refer to page VIII-12

<u>Item</u>	<u>P/N</u>	<u>Qty.</u>	<u>Description</u>
11	140145	4	1.00-8 X 3.5 LG SHCS
12	130719	1	PISTON BEARING (NOTE)
13	810767	1	MODEL 23 CLAMP SEAL KIT
14	100229	1	GREASE FITTING



MODEL 23
VIBRATORY
DRIVER/EXTRACTOR

PARTS LIST

VIII. ORDERING PARTS

F. RECOMMENDED SPARE PARTS (CONTINUED)

POWER UNIT - INTERNAL (51)

800587 Refer to page VIII-22-24

<u>Item</u>	<u>P/N</u>	<u>Qty.</u>	<u>Description</u>
16	300842	1	Return Filter Element
71	300706	1	Oil Filter Element
78	300702	1	Fuel Filter Element
80	300692	1	Fuel H2O Seperator Element
90	300704	1	Air Filter Element



**MODEL 23
VIBRATORY
DRIVER/EXTRACTOR**

PARTS LIST

G. RECOMMENDED TIGHTENING TORQUE

Nominal Screw Size	Nominal Socket Size	Tightening Torque Ft-Lbs. (Kg-M)	Nominal Screw Size	Nominal Socket Size	Tightening Torque Ft-Lbs. (Kg-M)
#10-24	5/32	6 Ft-Lbs. (.83 Kg-M)	#10-32	5/32	6 Ft-Lbs. (.83 Kg-M)
1/4-20	3/16	13 Ft-Lbs. (1.8 Kg-M)	1/4-28	3/16	15 Ft-Lbs. (2.1 Kg-M)
5/16-18	1/4	27 Ft-Lbs. (3.7 Kg-M)	5/16-24	1/4	30 Ft-Lbs. (4.2 Kg-M)
3/8-16	5/16	48 Ft-Lbs. (6.6 Kg-M)	3/8-24	5/16	55 Ft-Lbs. (7.6 Kg-M)
7/16-14	3/8	77 Ft-Lbs. (10.6 Kg-M)	7/16-20	3/8	86 Ft-Lbs. (11.9 Kg-M)
1/2-13	3/8	119 Ft-Lbs. (16.4 Kg-M)	1/2-20	3/8	133 Ft-Lbs. (18.4 Kg-M)
5/8-11	1/2	234 Ft-Lbs. (32.3 Kg-M)	5/8-18	1/2	267 Ft-Lbs. (36.9 Kg-M)
3/4-10	5/8	417 Ft-Lbs. (57.6 Kg-M)	3/4-16	5/8	467 Ft-Lbs. (64.5 Kg-M)
7/8-9	3/4	676 Ft-Lbs. (93.4 Kg-M)	7/8-14	3/4	742 Ft-Lbs. (102.5 Kg-M)
1-8	3/4	1,009 Ft-Lbs. (139.4 Kg-M)	1-12	3/4	1,126 Ft-Lbs. (155.6 Kg-M)
1-1/4-7	7/8	1,600 Ft-Lbs. (221.1 Kg-M)	1-1/4-12	7/8	1,800 Ft-Lbs. (248.8 Kg-M)
1-1/2-6	1	2,800 Ft-Lbs. (387 Kg-M)	1-1/2-12	1	3,000 Ft-Lbs. (414.6 Kg-M)

NOTE: These values are for Socket head cap screws only. Button heads, Flat heads and Set screws have different values. Check the Allen Hand Book for correct torque specifications.



MODEL 23
VIBRATORY
DRIVER/EXTRACTOR

PARTS LIST