

**APE D125-42 to D180-42**

**OPERATING MANUAL**



Corporate Office  
7032 S. 196th Street  
Kent, WA. USA 98032  
Tel: 1-800-248-8498  
Tel: 1-253-872-0141  
Fax: 1-253-872-8710

03/15/10

# CONTENTS

<b>Technical data.....</b>	<b>2</b>
<b>Major components.....</b>	<b>4</b>
<b>Working principle.....</b>	<b>6</b>
<b>Transport instructions.....</b>	<b>8</b>
<b>Transport protection.....</b>	<b>9</b>
<b>Guide of pile helmet.....</b>	<b>11</b>
<b>Fitting to lead.....</b>	<b>12</b>
<b>Batter piling.....</b>	<b>13</b>
<b>Lubrication instructions.....</b>	<b>14</b>
<b>Starting-adjusting-stopping.....</b>	<b>15</b>
<b>Instructions for adjustment of variable-delivery fuel pumps.....</b>	<b>17</b>
<b>Instructions for pile driving.....</b>	<b>18</b>
<b>Taking hammer out of operation.....</b>	<b>19</b>
<b>Trouble shooting.....</b>	<b>20</b>
<b>Maintenance.....</b>	<b>21</b>
<b>Safety regulations.....</b>	<b>27</b>
<b>Screw or bolt tightening torques.....</b>	<b>29</b>

## Technical data

Please bear in mind:  
We cannot take over any  
guarantee for pile hel-  
met and pile plate  
including cushion

Not all figures are exactly in accordance with the  
equipment supplied.

However, this has no influence to the function.

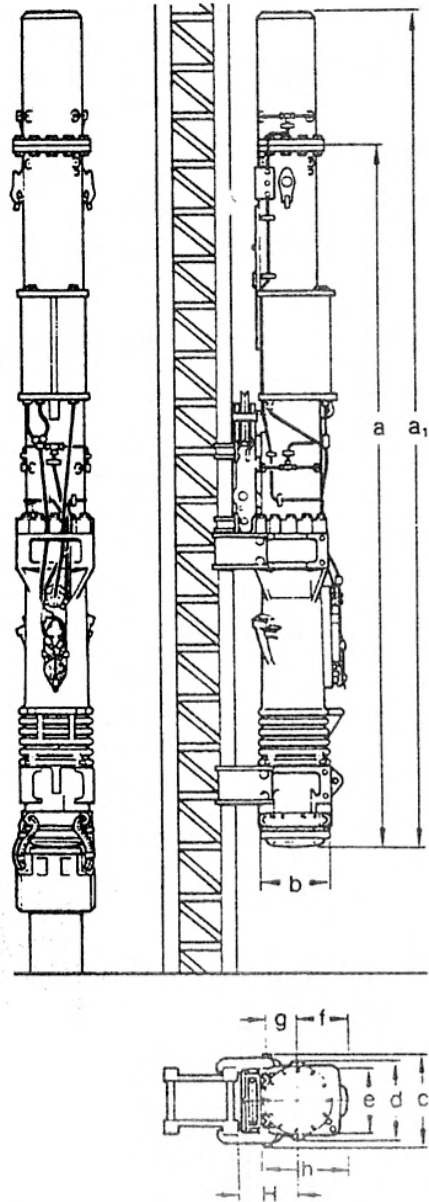

Subject to changes!

**D125-D180 SERIES DIESEL HAMMER OPERATING MANUAL**

Technical data for diesel pile hammer		Type	D125	D128	D138	D160	D180
Batter piling inclination up to			1:2	1:2	1:2	1:2	1:2
Impact weight (piston)		kg	12,500	12,800	13,800	16,000	18,000
Energy per blow		Nm	417,600 – 267,300	426,500 - 273,400	459,800 - 294,700	533,000 - 342,000	599,000 - 384,000
Blows per Minute		1/min	36-45	36-45	36-45	36-45	36-45
Force of explosion pressure on pile max.		kN (kp)	3,400 (346,704)	3,600 (367,098)	3,600 (367,098)	4,500 (458,872)	4,500 (458,872)
Suitable for driving piles, up to (The date mentioned refers to average values mainly valid for concrete piles. Depending on the soil conditions deviations are possible.)		kg	70,000	70,000	80,000	120,000	150,000
Permissible rope diameter for deflector sheave of tripping device max.		mm	Φ32	Φ32	Φ32	Φ37	Φ37
Consumption	Diesel Oil	L/h	36	36.6	40.5	46	54
	Lubricant	L/h	3.6	2.9	2.9	4.5	4.5
Capacity	Diesel oil tank (for vertical piling)	L	190	200	200	240	240
	Lubricant oil tank	L	60	28.6	28.6	40.3	40.3
Weights	Diesel pile hammer approx	kg	23,500 / 24,320	27,000	28,000	35,000	37,500
	Tripping device approx	kg	770	770	770	1,700	1,700
	Transport bracket/cradle approx	kg	220	950	950		
	Tool box approx.	kg	125	125	125	125	125
Dimensions	Length of diesel pile hammer (a/a1)	mm	6,663 / 7,783	7,600	7,730	8,020	8,150
	Outer diameter of impact block (b)	mm	910	960	960	1,070	1,070
	Width of guiding shoes, including fastener (c)	mm	1,210	1,260	1,260	1,160	1,160
	Width of diesel pile hammer (d)	mm	1,030	1,136	1,136	1,400	1,400
	Width for connection of guide jaws (e)	mm	850	910	910	1,020	1,020
	Center of diesel pile hammer up to pump guard (f)	mm	560	625	625	700	700
	Center of diesel pile hammer up to center of threaded hole for fastening screws of the guide jaws (g)	mm	370	420	420	465	465
	Standard distance from center of diesel pile hammer up to the center of lead (H)	mm	#	#	#	#	#

\* Standard tripping device is supplied without guide pulley. Guide pulley is available, when sheaving is required.

\*\* Guide pulleys available. # Dependant on leads used with hammer.

## Major Components

A Trip gear

A1 Guide gibs

A3 Lever

A4 Pawl

A5 Pawl lever

1 Cylinder upper part

1.1 Upper cylinder extension

2 Suspension plates

3 Fuel tank (lube oil tank and ether tank built-in)

4 Transport eyes

5 Carrier (on both sides)

6 Lube oil lines

7 Connecting screws

8 Catch for pawl lever

9 Lube oil pump

10 Fuel/breather line

11 Variable delivery fuel pump

12 Injection valve (s)

13 Pump guard

14 Cylinder lower part

15 Locking screw

16 Cylinder end ring (two part)

17 Rubber ring (two part)

18 Impact block

19 Plates to fit the guide tubes

20 Stop for pawl lever

21 Guide clamps

22 Exhaust openings

23 Catch groove

24 Striking weight (piston)

25 Catch piston ring

26 Cylinder sleeve (s)

27 Inner damping ring (two part)

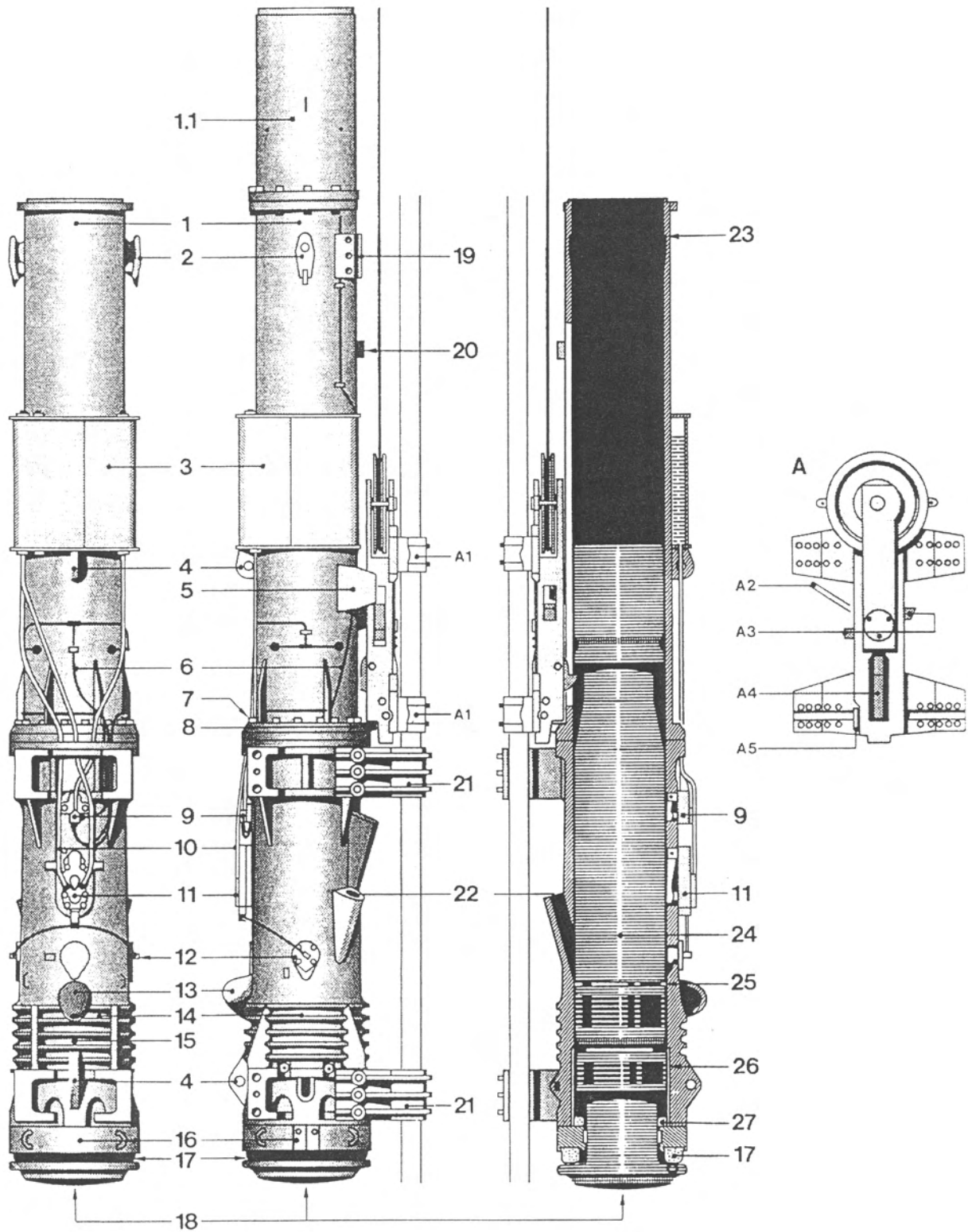

## Working principle

### 1 Trip gear

Means for raising and lowering pile hammer or piston respectively control by means of a winch of the carrier unit (crane excavator or pilling frame).

Lowering of trip gear (engaging piston)

1.1. Pull down lever (A2) as far as it will go and hold in that position.

As a result the sliding cams (A3) retract and the trip gear can slide past the carriers (5)

As soon as the pawl lever (A5) hits the stop (8) it will be pushed upwards and the pawl walks out thereby engaging into the ring groove of the piston. Let loose lever (A2)

1. 2. Raising and lowering of pile hammer

Do not pull lever (A2) downward!

The protecting sliding cams (A3) grab underneath the carrier (5), the pile hammer is held by the trip gear and can be moved into the required position.

1.3 Raising of piston (starting)

Always pull down lever (A2) as far as it will go and hold in that position! (sliding cams are retracted)

By means of the trip gear the piston is raised above the pawl (A4) and disengages at the stop (20) during the upwards movement.

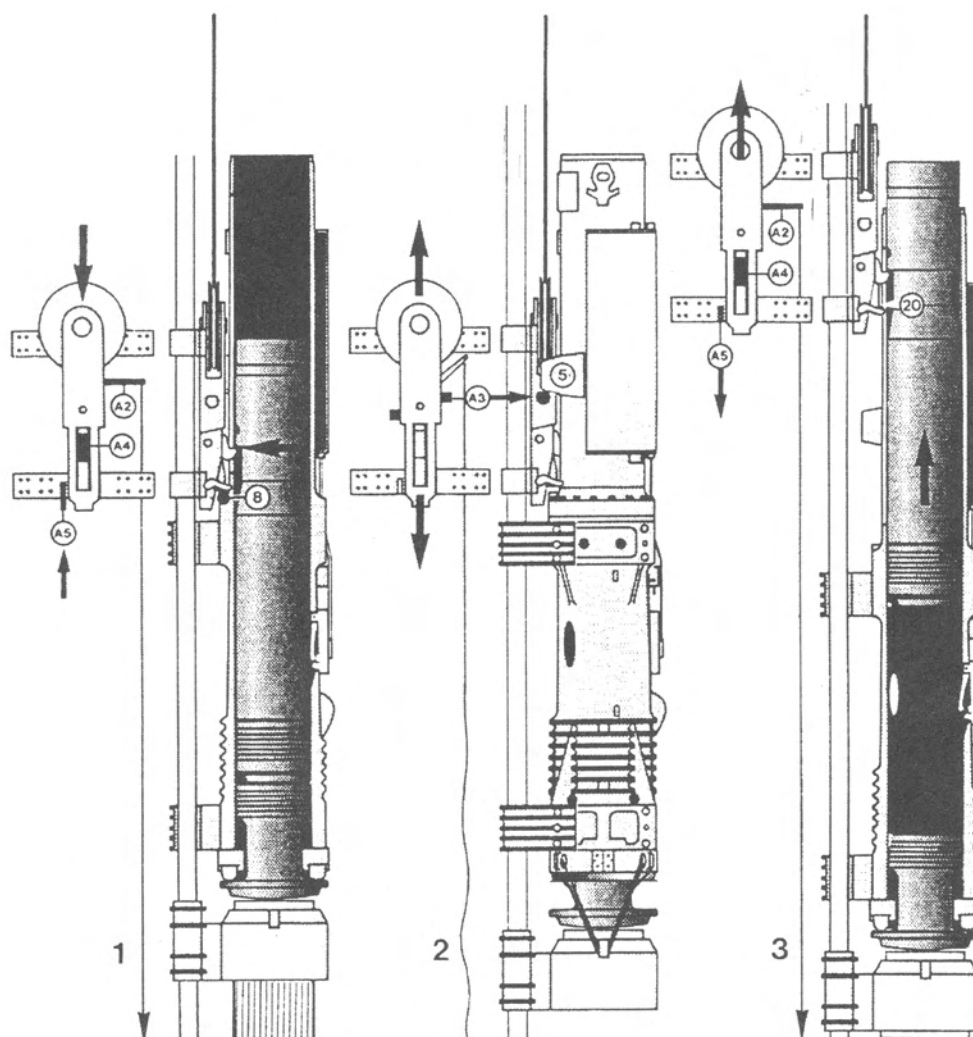

## 2 Diesel pile hammer

### 2.1 Injection of the Diesel oil and compression

The falling piston actuates the pump lever whereby a certain amount of Diesel oil is injected onto the surface of the impact block. As soon as the falling piston passes the exhaust ports, compression of the air trapped in the cylinder commences. The increasing compression presses the impact block and pile helmet firmly onto the pile head.

### 2.2 Impact and Explosion

When the piston end bus the impact block, the Diesel oil in the combustion chamber is atomized and the pile is driven downward into the ground.

The atomized fuel ignites in the highly compressed air and the resulting explosion energy drives the pile further into the ground and simultaneously throws the piston upwards.

### 2.3 Exhaust

The ascending piston opens the exhaust ports releasing the exhaust gases, and the pressure in the cylinder returns to normal.

### 2.4 Scavenging

As the piston continues to ascend, fresh air is sucked in through the exhaust ports thoroughly scavenging the cylinder and thereby releasing the pump lever. The pump lever returns to its original position sucking again diesel oil into the fuel pump.

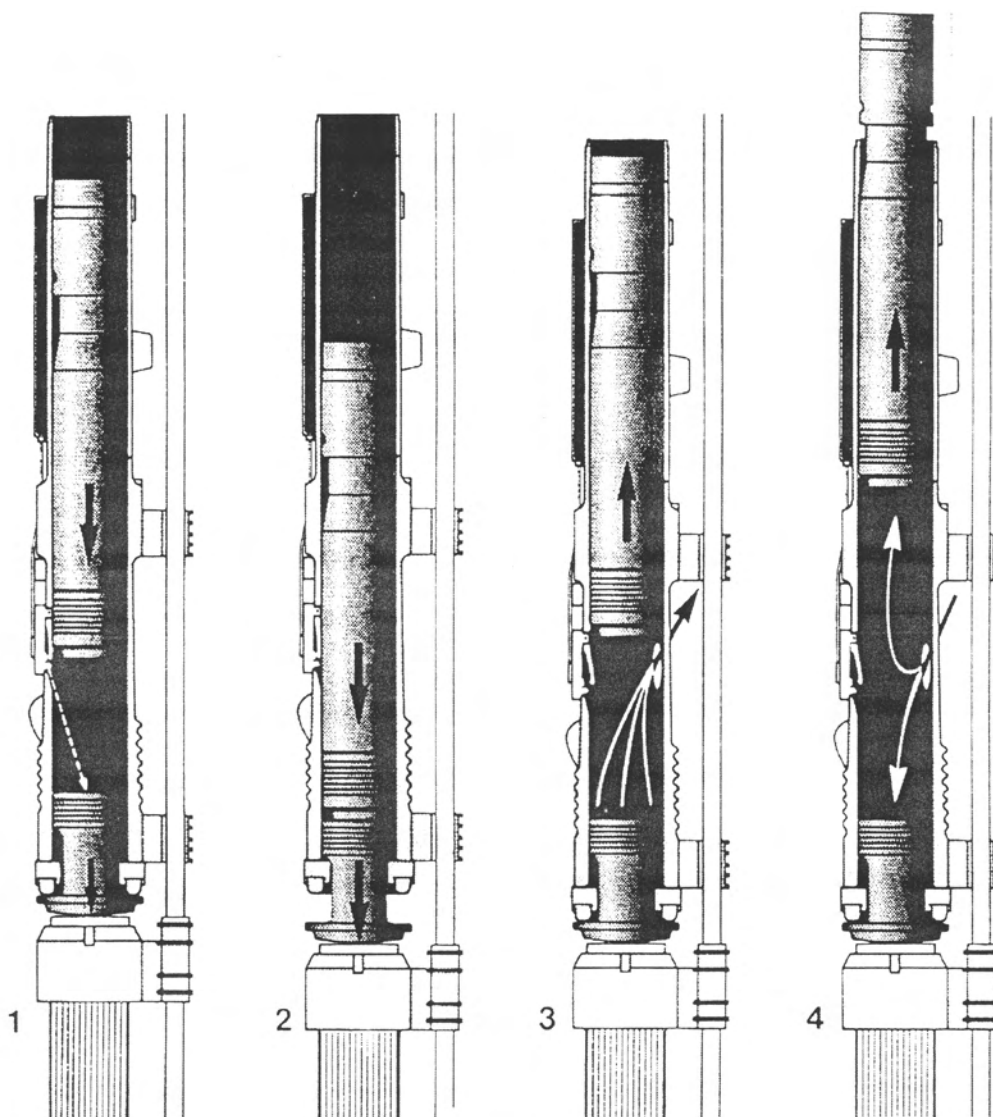



## Transport instructions

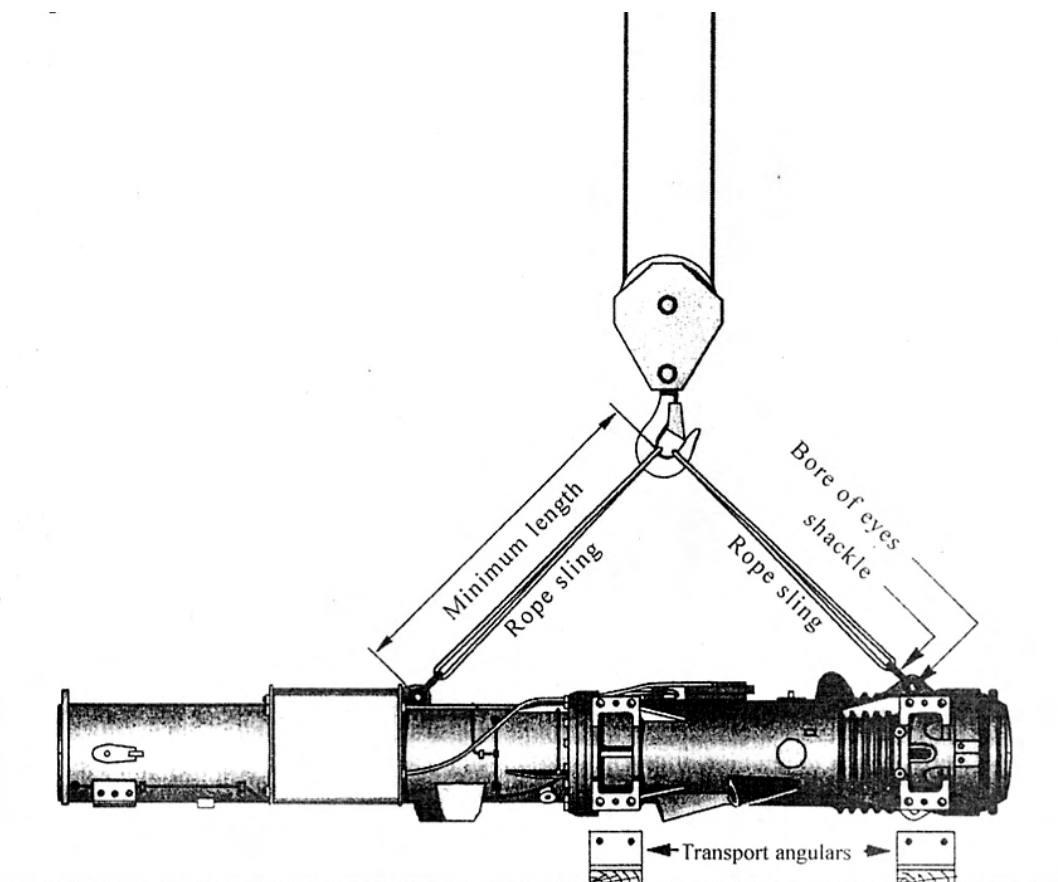

	D125	D128/D138	D160	D180
<b>2 Wire rope slings (DIN3066)</b>	Φ 36 mm 9 m	Φ 36 mm 9 m	Φ 40 mm 10 m	Φ 40 mm 10 m
<b>Minimum breaking strength of the single rope at 1700 N/mm<sup>2</sup> (Metric Tons)</b>	66.2 t	66.2 t	81.6 t	81.6 t
<b>Minimum length. If other ropes or chains are used they must be strong enough to bear the weight of the pile hammer safely.</b>	4.0 m	4.0 m	4.0 m	4.0 m
<b>Bore of the transport eyes approx.</b>	Φ 70 mm	Φ 62 mm	Φ 85 mm	Φ 85 mm
<b>Shackles, recommend size</b>	20	25	32	32
<b>Shackles rate (Metric Tons) (DIN82101)</b>	20 t	25 t	32 t	32 t

## Transport protection

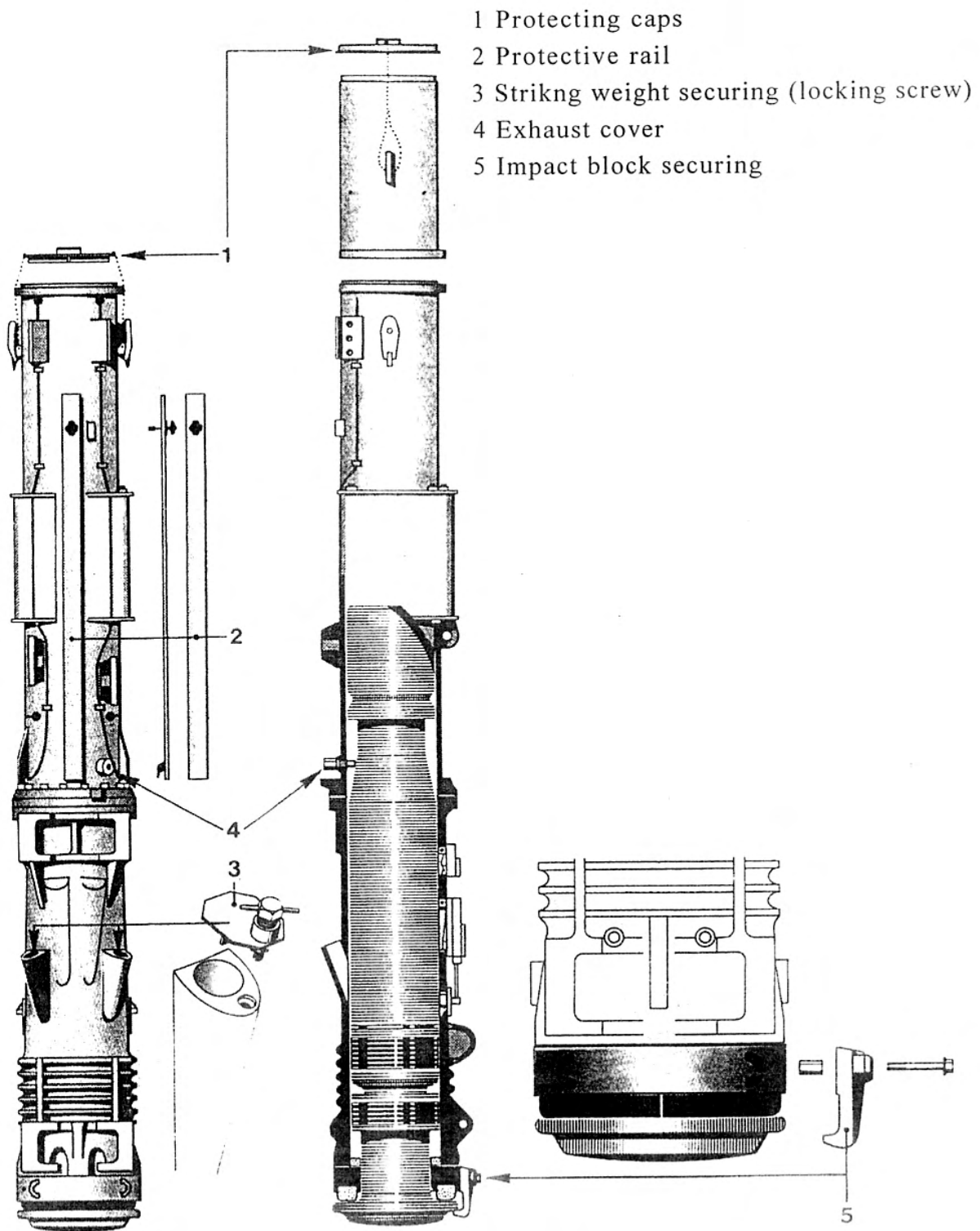

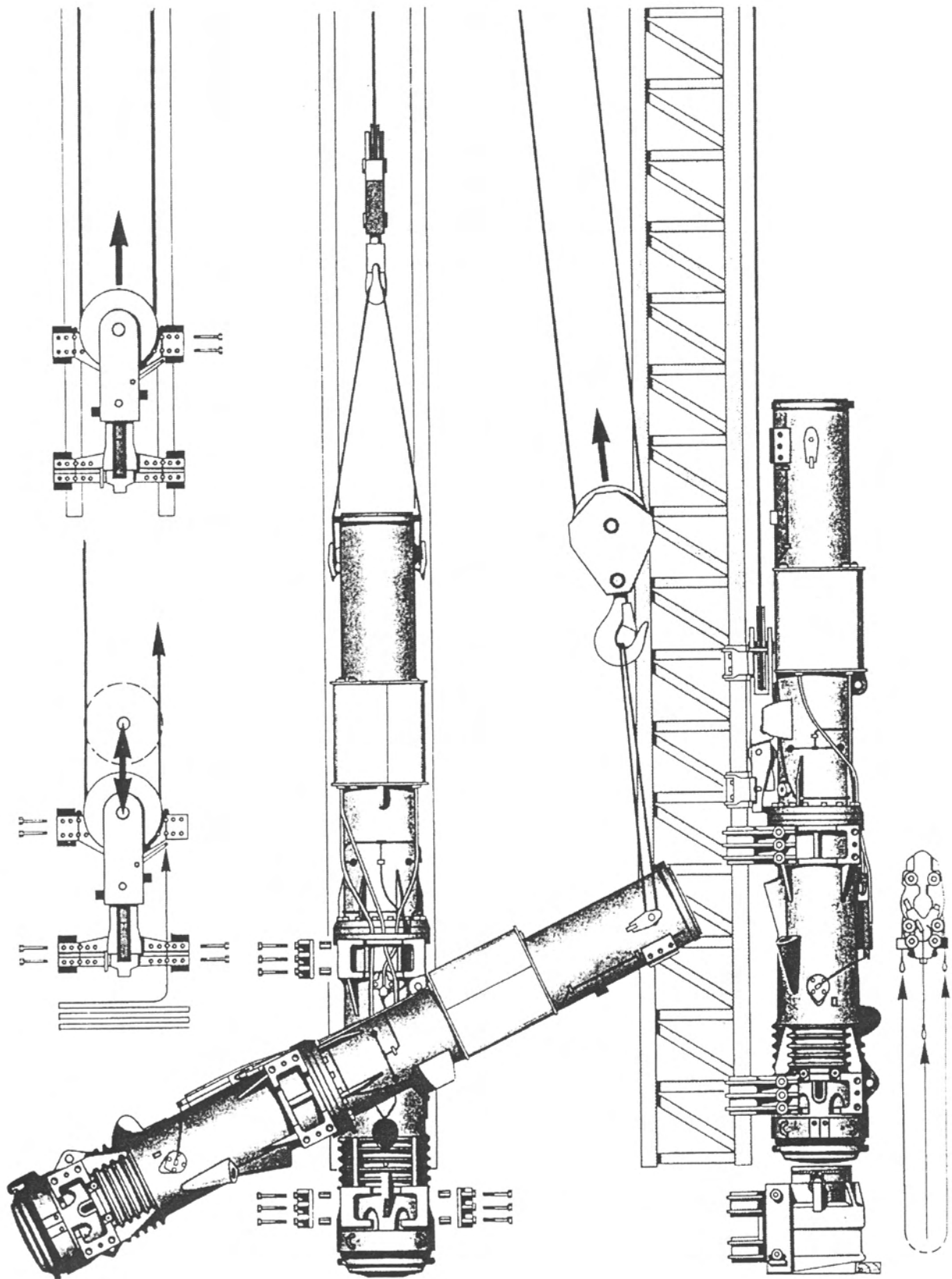

## Guide of pile helmet

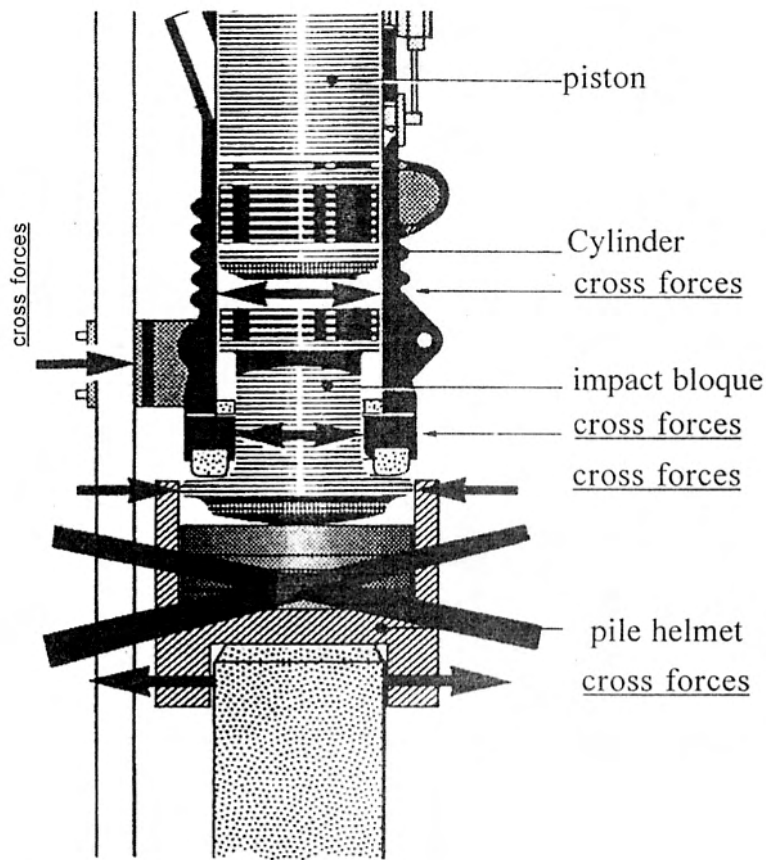

### Wrong

The pile helmet may not be guided at impact block.

Cross forces produce damages at impact block and cylinder.

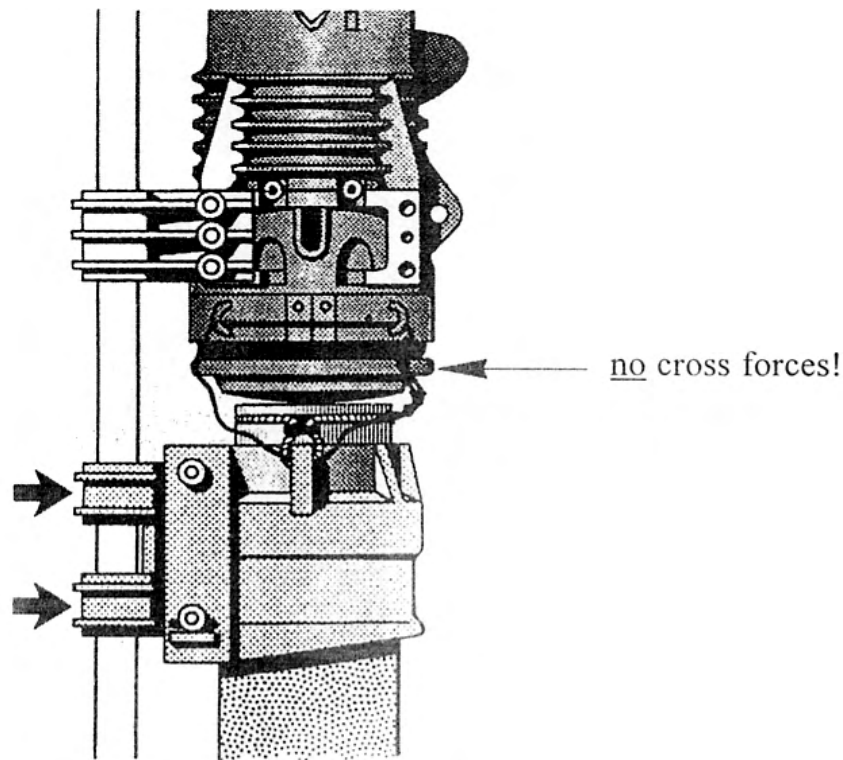

### Right

Guide pile helmet at lead!

## Fitting to lead

**1 Trip gear**

Attach both guide gibs to the bottom and one only to the top part of the trip gear. Raise trip gear, insert and attach second upper guide gib. Attach the 35m long rope (contained in he tool box) to lever (A2). Raise trip gear approx 6m.

**2 Diesel Pile Hammer and Pile Helmet**

2.1 Place transport skid with hammer in front of the lead. Remove bolts from connection points.

2.2 Attach rope slings (see transport instructions) Raise pile hammer.

2.3 Place hammer onto square timbers. Remove ropes.

2.4 Place wire rope around suspension plates (2) and hook. Raise hammer and place in front of the lead.

2.5 Fit guide clamps (21), both on lower and one only on upper part.

2.6 Raise hammer approx. 1m (3'3" ) slide guide clamps onto the lead and fit the second upper clamp.

2.7 Place pile helmet underneath hammer and lower hammer. Remove locking screw for piston and impact block securing clamp.

2.8 Raise hammer until impact block (18) is completely hanging out and is located approx.5cm (2" ) above the cushion block of the pile helmet. Attach pile helmet by means of cables and cable clips (contained in tool box) to end ring. Raise pile hammer and slide pile helmet onto the guide of the lead.

**Caution: Secure hammer to prevent it from dropping down. This is achieved by either securing hammer by means of a safety fork directly at the leads or by placing hammer onto a specially-designed safety mechanism built-into leads.**

2.9 Connect the 70m long regulating rope (in tool box) to the eyes of traction rope of the variable-delivery fuel pump. Attach 35 m rope on the middle rope sling of the pump (shut off valve).

2.10 Remove the wire ropes from the suspension plates.

2.11 Removal of protection cover, protective rail and exhaust port covers.

2.12 Fill up with diesel oil and lube oil. The filling holes are appropriately identified.

2.13 Raising of hammer on the leads. Raise the hammer approx 20cm (8" ), so that the specially-designed safety mechanism or catch fork respectively can be removed. Raise hammer far enough to allow placing hammer on the safety mechanism or catch fork respectively.

**3 The application of summer and winter Diesel oil**

3.1 The use of diesel oil unsuitable for the respective season of the year will cause starting difficulties. Therefore always be sure you buy Diesel oil suitable for the respective season.

3.2 When using normal summer diesel oil during the cold period at temperatures of -8 to -10°C (17.6 to 14° F). Paraffin is separated and prevents the proper feeding of the fuel pump. At even lower temperatures the fuel supply to the pump can be blocked completely.

3.3 Winter diesel oil which during the cold season is available at filling stations can be used at temperatures as low as -30°C (-22° F) provided it contains at least 50% fuel additives.

The following fuel additives should be used: Motor petroleum, Tractor fuel, Regular gasoline.

**Mixing ratio (in percent)**

outside temperature	summer diesel oil	fuel additive	winter diesel oil	fuel additive
up to -10° C	90%	10%	100%	—
up to -14° C	70%	30%	100%	—
up to -20° C	50%	50%	80%	20%
up to -30° C	—		50%	50%

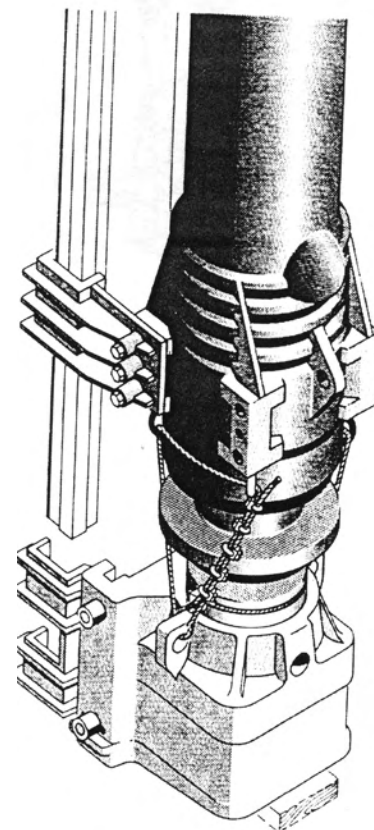

## Batter piling

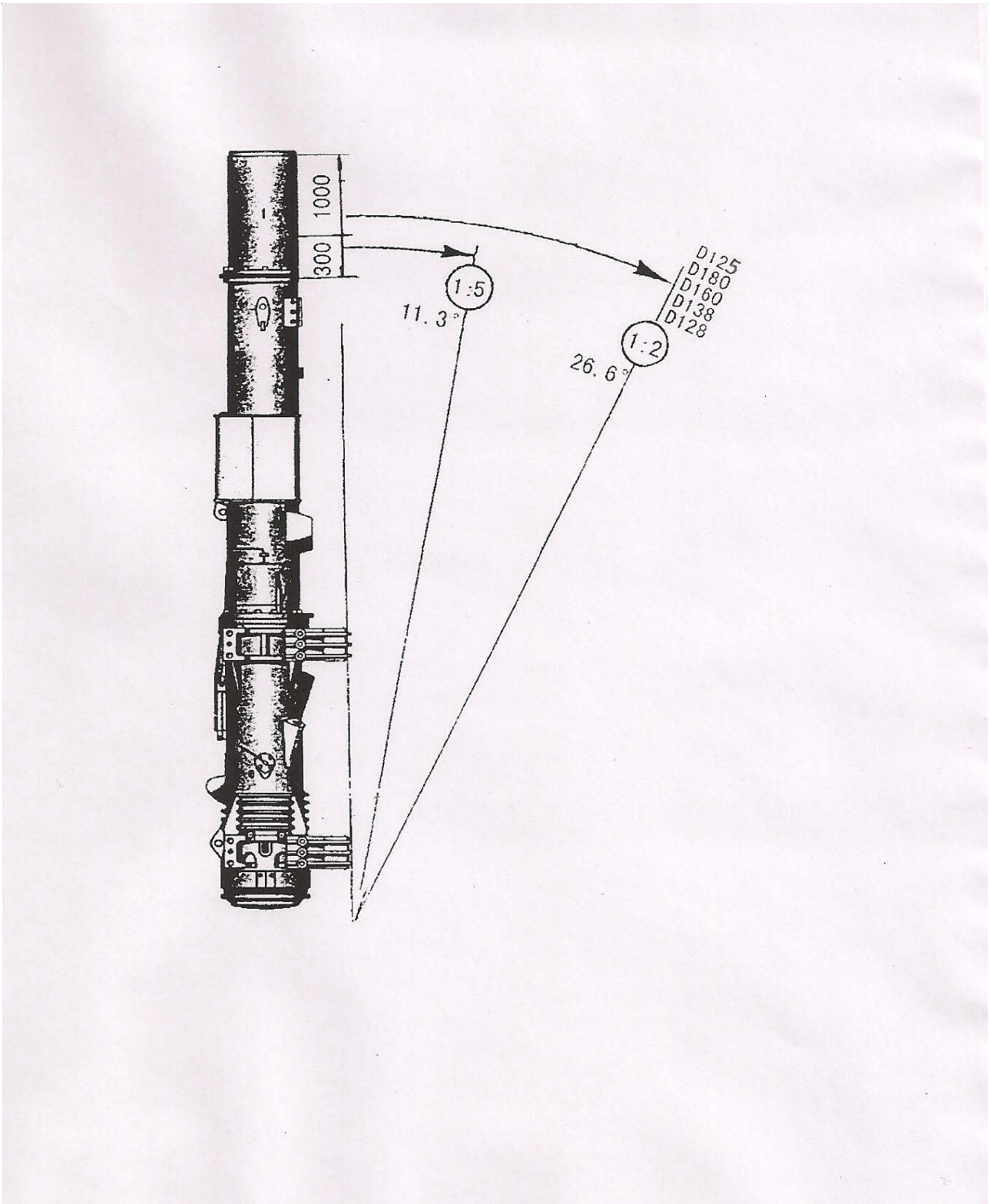

## 9 Lubricating Instructions

1) Check oil level in lube oil tank. The tank should be at least half full.

2) Disconnect lube oil pressure lines from pump.

3) Fill lube oil pressure line from below using a force-feed oil can until oil runs from each pipe socket. Then re-connect hoses with pump.

#### 4) Lubrication.

Always top up tube oil tank when refueling.

#### 5) Vertical pile driving

Automatic lubrication of the upper cylinder part by the lube oil pump. The addition of lube oil additives is to be recommended (1L additive to 20L lube oil). Grease impact block and cylinder end ring every hour with special grease (5 pump strokes per nipple from the grease gun).

The lubrication points are identified. Do not lubricate when impact block is hanging out.

The trip gear has to be lubricated with special grease (5 strokes per nipple with grease gun ) every week.

Lubricate the guide tubes of the lead once per week. (Multi-purpose grease containing  $\text{MOS}_2$  e.g. LM 145 from Acheson industries Inc., or similar)

#### 6) Piling under Batter or Inclination

6.1 Automatic lubrication of the upper cylinder part by the lube oil pump. In addition to greasing the impact block and cylinder end ring every hour by using a grease gun (5 pump strokes per nipple) it is necessary to grease the upper cylinder part as well.

6.2 It is necessary to add lube oil additive, ratio 1:20, when batter piling at inclinations larger than 1:10.

#### 7) BEL -RAY Molylube Friction Modifier (in USA: Molylube Modifier Ao-2)

##### 7.1 Lube oil

Summer: Motor oil SAE 40/50

Winter: Motor oil SAE 20

##### 7.2 Special greases

Almasol 1250 Hight temp

BEL -RAY Molylube 126 EP grease 2

Molylube 26 HD

Molykote FB 180

TRC Moly hi temp

Rocol MHT or equivalent.

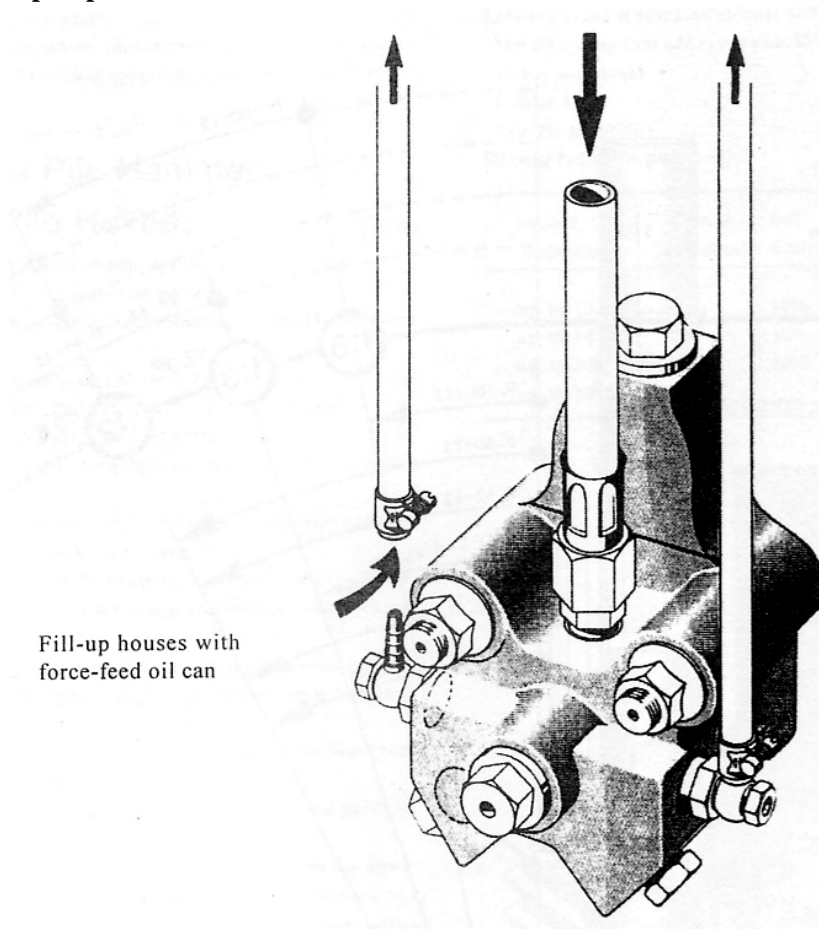

Fill-up houses with force-feed oil can

## Starting--adjusting--stopping

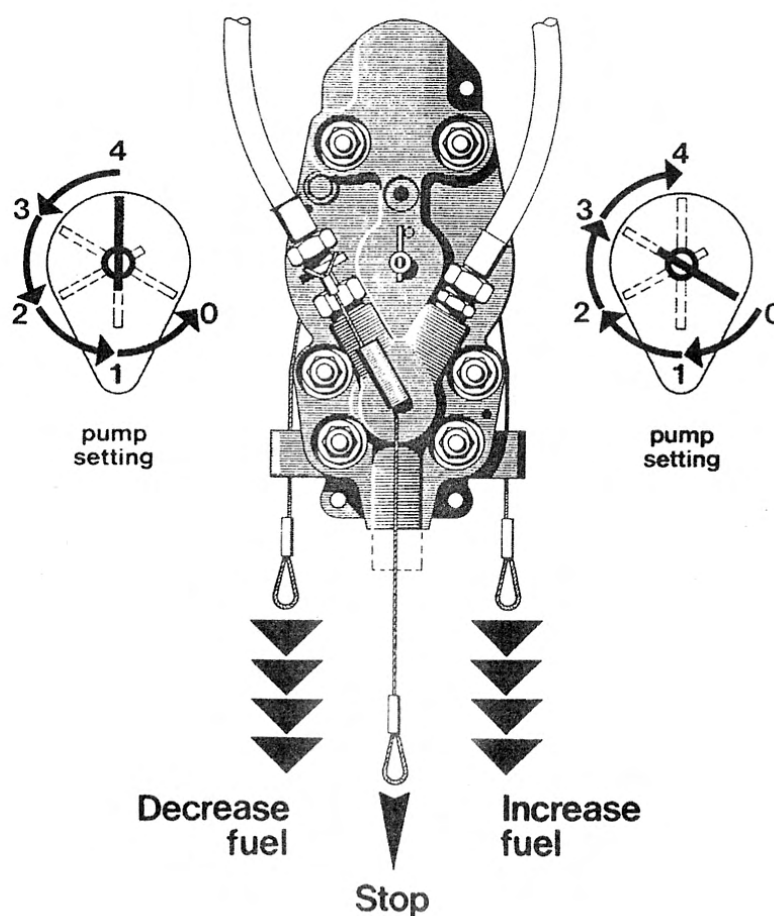

### **1 Operating hints**

The energy per blow (piston stroke) is governed by the variable delivery-fuel pump. Actuation of the fuel setting device is by pulling the regulating rope. At each pull of the rope, with is limited by a stop, the setting device moves one step forward or backward depending on whether the left or right hand rope has been pulled.

#### **1.2 Pulling the right hand-rope**

Switching from (stop) position 0 to 1-2-3 up to 4 (maximum).

#### **1.3 pulling the left hand-rope**

Switching from position 4 (maximum) down 3-2-1 to 0 (stop). The position of the setting device can be checked on the dowel sleeve at the regulating shaft.

1.4 Switching should only be carried out when the pistons resting on the impact block, or hitting the block when in operating.

### **2 Bleeding of variable delivery fuel and injection valves**

2.1 Only required on new hammers, after repairs or in case of stoppage due to lack of fuel. The bleeding must be performed while the piston is raised as only then the pump lever is reloaded and the pawl of the trip gear is about 20 cm below the catch (5) of the upper cylinder.

2.2 Set fuel pump on position 4, loosen swivel joint on the injection valve (do not remove completely) only 2-3 turns then pump by pulling the regulating rope till bubble free fuel flows from the swivel joint and only then release rope. Open stop valve with its rope, so the air is released through the fuel line and tank. Keep the stop valve app. 5 seconds open and then close it. This must be repeated 3 times.

### **3 Cleaning of the combustion chamber**

3.1 Once daily, immediately before the first start, the lube oil accumulated in the combustion chamber must be



removed. Otherwise it is possible that the combustion of the additional lube oil will cause the piston to travel as high as the safety catch groove Set fuel pump (17) to "0" .Remove plug (21).

3.2 Raise and drop piston five times (cold blows), so that the oil can escape through the threaded opening. On completion replace plug (21).

**4 starting-up**

4.1 When starting, set the variable delivery fuel pump to "0" for the first blow.

4.2 For the second start, the setting should be stage "3". Switch to stage "4" when the pile hammer is running.

**4.3 Regulation**

The amount of fuel injection to meet the prevailing piling conditions; an be varied by pulling the fuel regulating rope (refer to point 1 as well as "angle of energy per blow within the regulation possibility")

**4.4 pumping between blows**

Attention: This measure may only be taken on piles with large set per blow.

Set variable delivery fuel pump to position "4" Vividly pull the right hand rope when the piston is at its top dead centre.

**5 Stopping**

5.1 Interrupt fuel supply by pulling the rope of the stopping valve. Hold rope until the piston has come to rest on the impact block.

5.2 Set variable delivery fuel pump by pulling the left-hand rope to position "0".

**6 Range of energy per blow within the regulation possibility.**

<p><b>D125 Pump setting</b>                      Position 4=100%=417,000 Nm                      Position 3=89.7%=374,000 Nm                      Position 2=77.2%=321,900 Nm                      Position 1=64.1%=267,300 Nm</p>	<p><b>D138 Pump setting</b>                      Position 4=100%=459,800 Nm                      Position 3=89.7%=412,400 Nm                      Position 2=77.2%=355,000 Nm                      Position 1=64.1%=294,700 Nm</p>	<p><b>D180 Pump setting</b>                      Position 4=100%=599,000 Nm                      Position 3=89.7%=537,300 Nm                      Position 2=77.2%=462,400 Nm                      Position 1=64.1%=384,000 Nm</p>
<p><b>D128 Pump setting</b>                      Position 4=100%=426,500 Nm                      Position 3=89.7%=382,600 Nm                      Position 2=77.2%=329,300 Nm                      Position 1=64.1%=273,400 Nm</p>	<p><b>D160 Pump setting</b>                      Position 4=100%=533,000 Nm                      Position 3=89.7%=478,000 Nm                      Position 2=77.2%=411,500 Nm                      Position 1=64.1%=342,000 Nm</p>	

## Instructions for adjustment of variable-delivery fuel pumps

- 1 Only applicable to variable delivery fuel pumps and fuel injection devices with the order numbers given in the table.
- 2 The check dimension of variable delivery fuel pumps must be checked from time to time to assure proper operation of the diesel pile hammers.
- 3 This dimension (clearance between pump seating face and highest point of pump lever when set pump on position 4) determines the stroke of the pump element and thus the fuel delivery rate.
- 4 Wear, e.g. on the pump lever or guide sleeve of pump element reduces the fuel delivery rate. This wear can be made good by changing the shim (s) in the thrust pin.
- 5 Never grind the pressure piece or mushroom.
- 6 Please ensure that only original APE fuel lines are used and the valve piston in the injection valves run smoothly and seal properly.

Diesel pile hammer	Injection valve complete Qty.	Pump element complete Dia. mm	Check dimension mm	Fuel delivery rate(stroke)at full-load(pump on position 4) cm <sup>3</sup> /stroke
<b>D125</b>	4	39	55+0.3	15.5
<b>D128</b>	4	38	57.8+0.3	14.5
<b>D138</b>	4	40.5	57.8+0.3	16.5
<b>D160</b>	4	43.5	57.8+0.3	19.3
<b>D180</b>	4	48	57.8+0.3	23.5

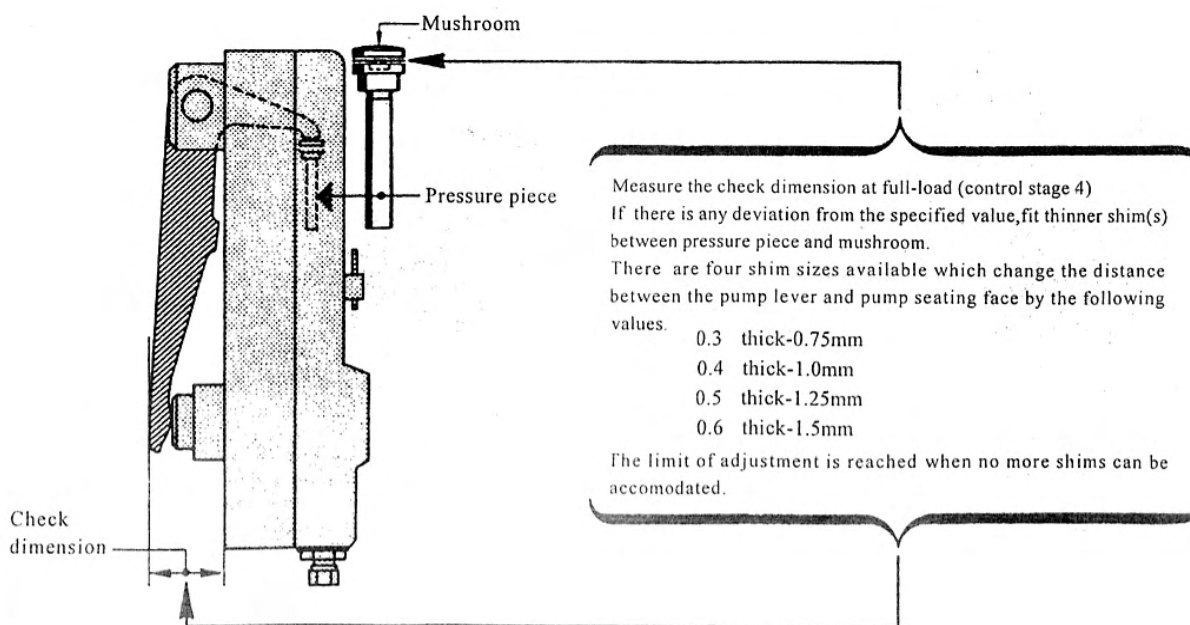

## Instructions for pile driving (Very important)

- 1 A diesel pile hammer must never be started up unless it is resting on a pile or on a specially prepared test stand.

2 Never start up a diesel pile hammer with the impact block hanging out.

The impact of the piston would be transmitted directly to the cylinder end-ring above the impact block, destroying the end-ring and damaging the lower part of the cylinder.

3 Never start up a diesel pile hammer which has been disconnected from the lead or which is resting on a skid, etc., as this may cause an accident.

4 Never drive piles eccentrically.

For trouble-free pile driving it is of paramount importance that the impact surface of the pile head should be square and level. The center line of the pile must be accurately aligned with the center line of the pile hammer, and must have the same line of travel. If this basic rule is not observed the pile hammer may rebound, which could cause the cylinder to crack and/or buckle. Moreover, rebounding impacts will also cause the pile to vibrate, misaligning it and possibly even destroying it if it is made of concrete.

Remedy:

Use a suitable pile helmet guided on the lead. However, even the use of a pile helmet cannot always prevent the pile from deviating slightly from its original line. The pile foreman must keep a constant check on the work in progress and must correct the lead immediately if the pile shifts out of line.

If the pile helmet is not guided on the lead the pile, etc., must be held to the lead with one or more pile guides.

5 Should think to replace the diesel pile hammer which has been bigger striking energy according to the actual working condition if the pile sinks less than 50mm per 10 impacts.

Shut down the pile hammer if the pile sinks less than 20mm per 10 impacts.

Slower penetration is possible, but it leads to more rapid wear of the pile hammer.

6 If pile penetration is slow, check for excessive piston "rebound". Ensure that it does not strike the arrester groove in the upper cylinder. Regulate the pile hammer or shut it down in good time.

7 Keep clear of the pile hammer while it is in operation. Risk of accidents!

8 Frequent checks are necessary to ensure that the guide clamps and guides are firmly attached.

9 Replace worn or buckled guide clamps and gibs immediately. Otherwise the hammer may jump out of the guide and cause an accident.

Maximum clearance between the guide clamps or gibs and the guide tubes of the lead must not exceed the values shown. Check constantly.

10 Do not use a lead if buckled. It may cause an accident.

11 When batter oiling never exceed the permitted batter for the pile hammer being used. Risk of accidents!

12 If damage to the pile-driving equipment or the pile is discovered or predictable. Stop all work immediately.

13 Always make sure that all parts are properly lubricated.

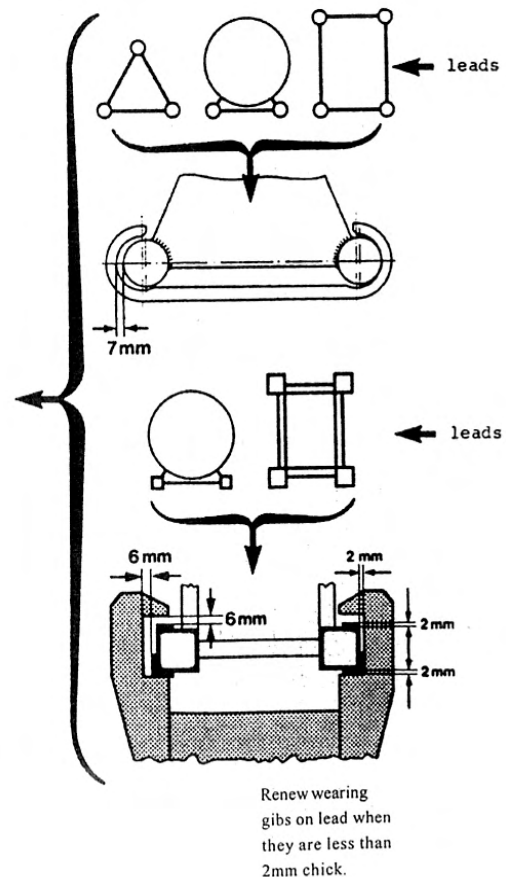

## Taking hammer out of operation

### 1 With piles:

1.1 Drive in pile to at least half its length. Set down hammer on pile Raise trip gear slightly.

1.2 Put on protective cover. Attach protective rail and screw on exhaust port covers.

1.3 On crane:

Switch off engine (s) and remove ignition key. Close flaps and windows. Lock doors.

### 2 Without piles:

2.1 Either set down lead and pile hammer on the ground and raise rope of trip gear slightly, or secure hammer at bottom of lead with safety mechanism of catch fork. In this case do not tension rope of trip gear.

2.2 Fit protective devices

### 3 Removing from lead:

3.1 Additional requirements:

Tighten piston securing screw. Attach impact block securing clamp. Remove ropes from variable-delivery fuel pump.

3.2 If transport skid is to hand, place hammer on it and secure. If transport skid is not available, place hammer on square timbers.

### 4 Storage:

If hammer is stored in the open, cover it with a tarpaulin or PVC sheeting. If it is likely to be out of use for a prolonged period of time, it must be protected against corrosion.

### 5 Anti-corrosion treatments:

5.1 Unprotected surfaces become corroded when they are exposed to both oxygen and moisture. Corrosion can be prevented by applying a protective coating which completely covers the surface.

5.2 The higher the viscosity of the protective coating, and the tougher and thicker it is, the better the protection will be.

5.3 For pile hammers we recommend Moly Grease 129; this is a heavy grease which can be applied with a cloth or a brush.

5.4 To apply the grease, disassemble the hammer and carefully remove all dirt and rust. Then coat all parts thoroughly with grease, including the bore-holes in the upper and lower cylinder, and the end ring.

5.5 Re-assemble hammer. Be sure to refit protective rail, protective cover and exhaust port covers.

5.6 The pump, injection valve (s) and line must remain filled with fuel or lubricant.

## Trouble shooting

### 1 Water in the combustion chamber:

1.1 During the compression cycle on a cold hammer, cold or damp air that had been sucked into the cylinder is condensed to water and atomized together with the fuel when the piston hits the impact block. The atomized water reduces the compression temperature so that the diesel oil can not ignite in the cooled-off compressed air.

Remedy: blow out cylinder. Remove locking screw (1 5). Set fuel pump to "0". Raise piston and trip it several times. Replace locking screw.

1.2 When filling the fuel tank, condensed water that has accumulated in the fuel container has found its way into the fuel tank.

#### 1.2.1 Remedy:

Remove fuel line from fuel pump. Drain off water until uncontaminated diesel oil appears, reconnect fuel line. Bleed fuel pump. Open locking screw (15) and blow out cylinder.

1.3 Water can enter the combustion chamber in various way:

Remedy: As explained under 13.1.2.

1.4 When condensed water has accumulated in the diesel oil tank.

Remedy: As explained under 13.1.3.

Very important: Accumulation of condensed water can normally be prevented if the diesel oil tank is completely filled up with diesel oil every evening after termination of work.

### 2 Pile penetrates too fast:

2.1 When the pile penetrates too rapidly into the ground, impact block and piston separates too fast on impact. As a result, the compressed air expands and the atomized diesel oil cannot ignite because the compression temperature is no longer sufficient for the ignition of the diesel oil.

#### 2.2 Remedy:

Set fuel pump on "off" position. Raise piston that often and trip it until resistance to penetration of pile is high enough to resume starting of hammer.

### 3 Fuel pump injects too little diesel oil:

#### 3.1 Remedy:

3.1.1 Check whether there is sufficient diesel oil in the fuel tank, fuel is reaching pump. If not, clean filter (see "Maintenance").

3.1.2 Pump is at correct delivery setting.

### 4 Fuel flows continuously into the combustion chamber:

#### Remedy:

Remove fuel pump. Remove check valve from bottom of pump body. Also remove injection valve (s). Inspect and clean valve seats. Replace worn parts. If this fails, check all valves.

### 5 Worn piston rings:

If compression is too low (see "Maintenance") check piston rings of impact block and piston and renew it if necessary.

### 6 Use of unsuitable diesel oil:

6.1 When using regular summer diesel oil during the cold season for instance, paraffin is separated either preventing proper feeding of the fuel pump or blocking completely the supply of diesel oil to the fuel pump.

6.2 Make, therefore, always sure that diesel oil which is suitable for the respective season of the year is used.

**Never use gasoline! Diesel hammer runs on diesel oil only.**

## Maintenance

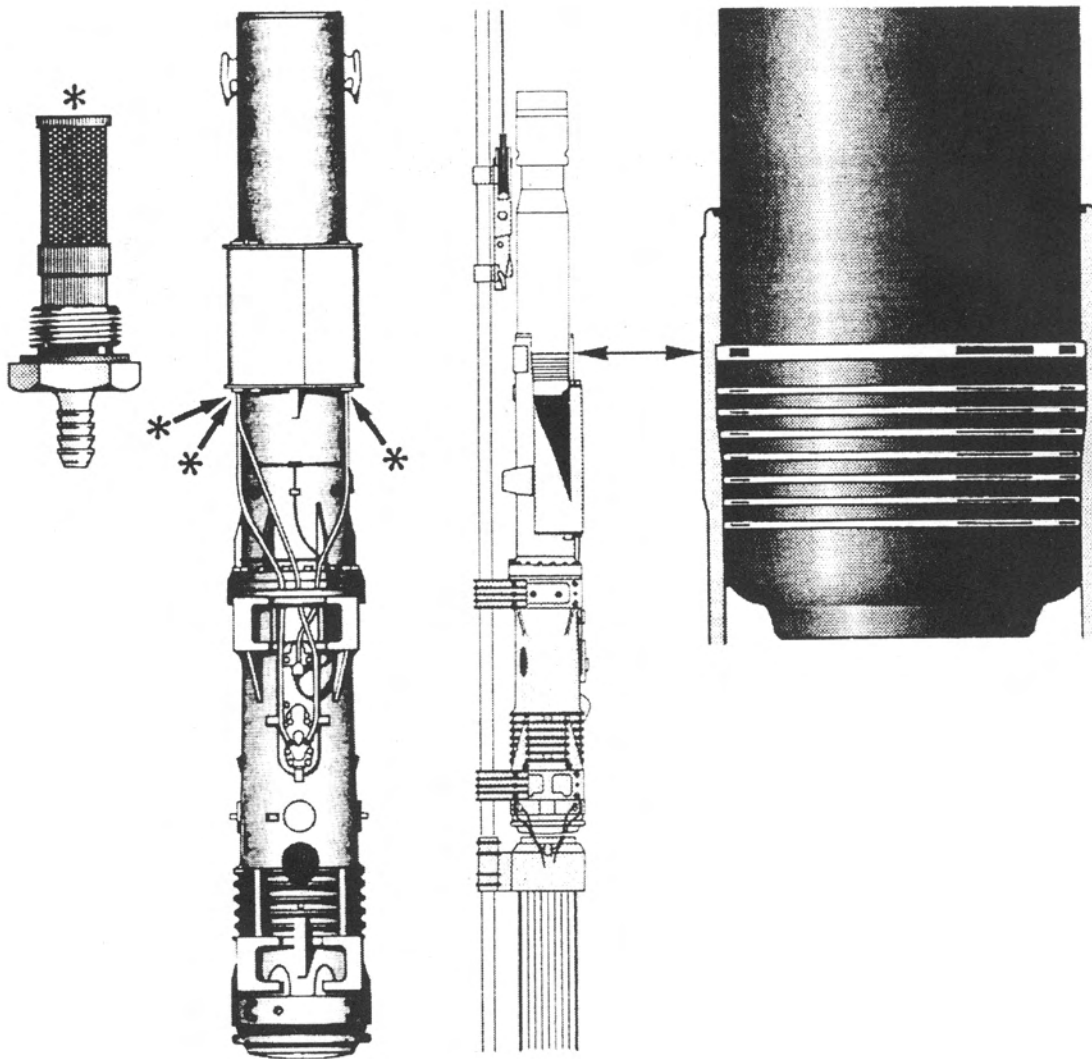

### 1) Cleaning the filter (once a month)

Empty fuel and lube oil tanks. Remove fuel and lube oil lines. Remove and clean filter nozzles.

### 2) Catch groove and catch piston ring

2.1 When the pile meets strong resistance, piston travel can increase so much that the catch ring hit the catch groove in the cylinder upper part.

2.2 If this occurs, immediately reduce fuel injection by diminishing fuel pump setting respectively shut off hammer and interrupt driving. Catch groove and catch piston ring must always be in a perfect condition.

2.3 Immediately rework catch groove if latter is damaged as otherwise there exist Danger of accident!

### 3) Testing the compression

3.1 Caution: Never check compression on hammer when same is secured on leads by means of the safety mechanism or safely fork..

#### **Danger of Accident!**

3.2 Fuel pump is set on "off".

Raise piston and trip. There is sufficient compression if the piston after its hitting the impact block is thrown upwards through the compression and falls back onto the impact block after 5-6 additional up and downward

movements.

#### 4) Screw joints

4.1 Important: When commissioning a new Diesel hammer check all nuts and bolts for tightness after 1.5 and 10 hours work.

4.2 During piling operation check regularly all screw joints, especially the bolts of guide clamps on the hammer and the bolts of guide gibs on the trip gear.

#### 5) Disassembly of pumps (see spare parts list)

5.1 When the job has been completed the seats must be coated with "Hylomar" sealing compound before the pumps are fitted the following instructions must be observed.

##### 5.2 Properties of Hylomar SQ32H

- Base: polyester-urethane compound
- Flashpoint: non-inflammable
- Temperature stability: -50° C to +300° C
- Shelf life: unlimited
- Coverage: approx. 12mg/cm<sup>2</sup>

#### 6) Application procedure

##### 6.1 Degreasing

The surfaces to be sealed must be cleaned thoroughly with trichloroethylene, nitro thinners or benzene.

Allow degreasing agents to evaporate.

##### 6.2 Application

Even coating of both surfaces will ensure optimum sealing and prevent the formation of air pockets.

After coating surfaces wait 10 to 15 minutes before assembling, to allow volatile elements to evaporate.

Sealed surfaces can be separated and rejoined up to 3 times without applying fresh compound, provided care is taken to prevent contamination of the sealed surfaces by impurities or foreign bodies.

##### 6.3 Cleaning

Scrape off old sealing compound with a blade, then clean the surface thoroughly with a cloth saturated with trichloroethylene.

Tighten pump retaining nuts to 280 N-m (206 lb-ft).

#### 7) Exchanging of rubber ring (damping ring)

7.1 Set down hammer on pile helmet and remove impact block securing clamp.

7.2 Raise hammer until impact block hangs out completely. Then press the two-part rubber ring out of the dovetailed groove by means of a screw driver.

7.3 Place the new rubber ring on the impact block flange.

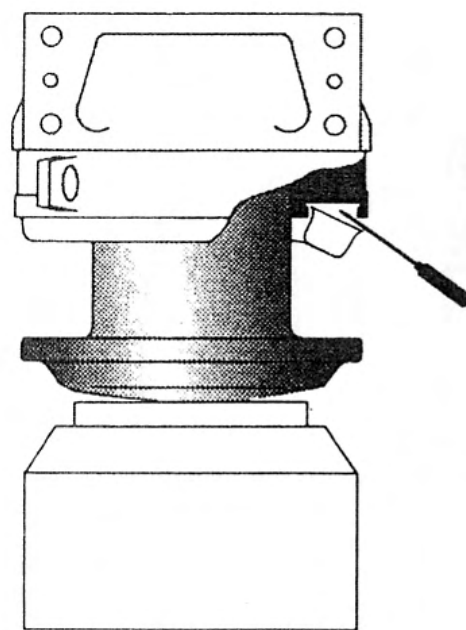

2.

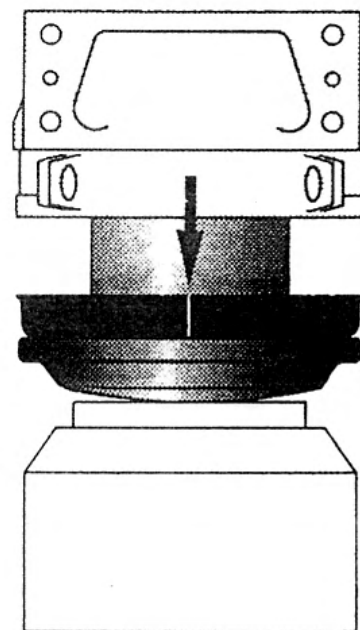

3.

Lower hammer. The hammer presses the rubber ring into the dovetailed groove by its own weight.

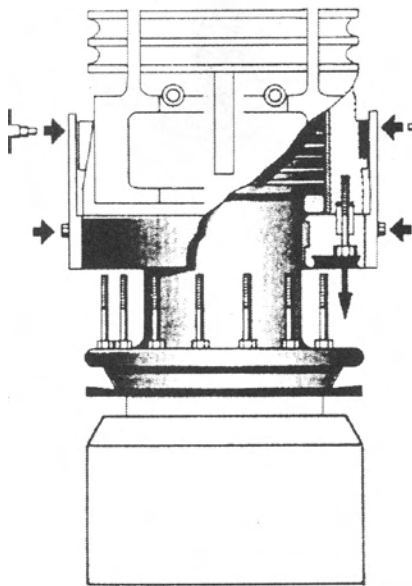
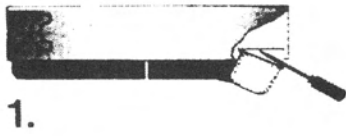

2. → 4.

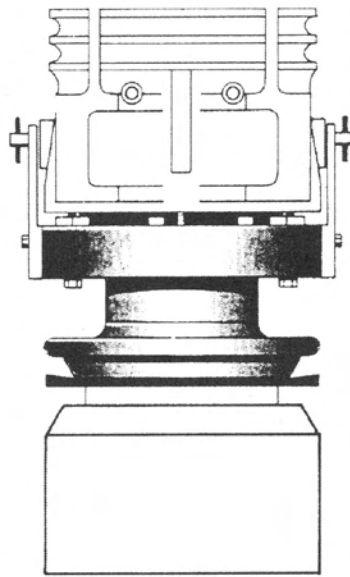

5.

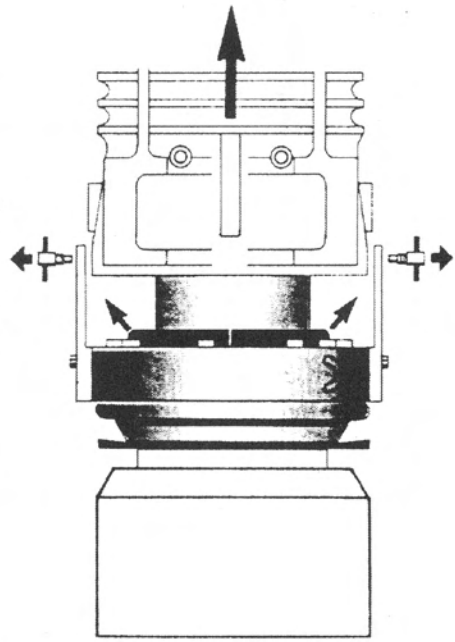

6.+ 7.

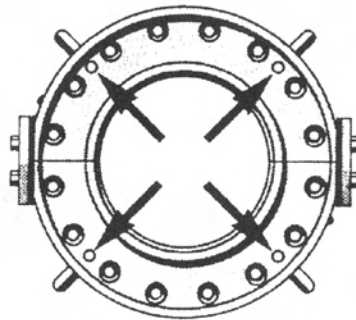



**8) Changing inner rubber ring**

- 8.1 Remove rubber ring.
- 8.2 Secure impact block with wedges against tipping over.
- 8.3 Fit assembly plates to the two-part cylinder end ring and screw in assembly bolts.
- 8.4 Remove all necked-down bolts from cylinder end ring.
- 8.5 Squeeze off end ring from cylinder lower part by means of 4 necked-down bolts. (Squeeze-off distance is restricted by the assembly bolts which engage into cylinder lower part).
- 8.6 Set down pole hammer on impact block flange. Remove assembly bolts.
- 8.7 Raise hammer and secure it at a level just high enough to allow the rubber ring to be replaced without difficulty.
- 8.8 Re-assemble in reverse order.

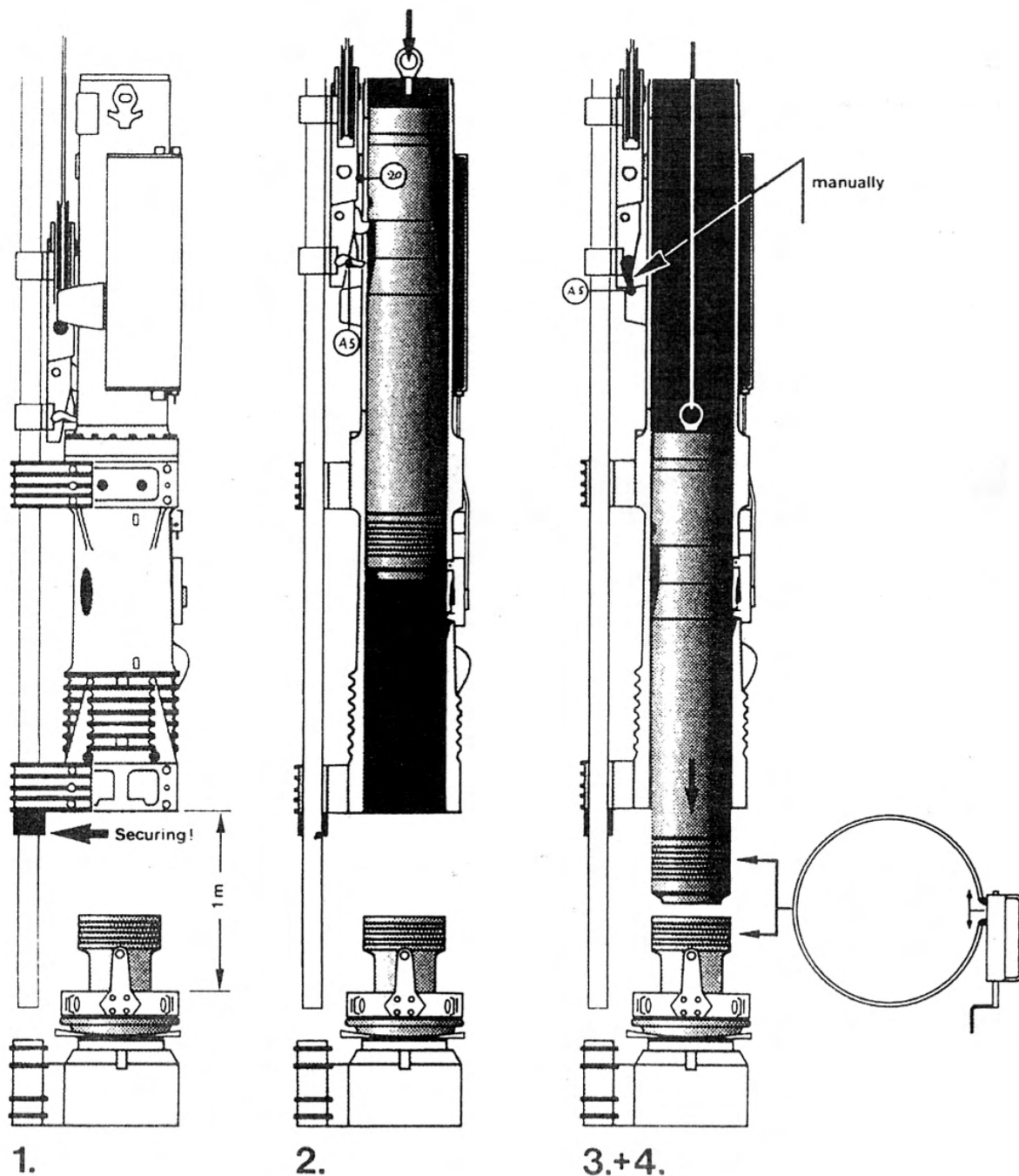

### 9) Changing piston rings

Method of disassembly is the same as that for replacing inner rubber ring.

9.1 After removing assembly bolts raise hammer approx. 1m and secure it. The cylinder end ring held together by the assembly plates remains on the impact block flange.

9.2 Raise piston and stop raising shortly before the carrier (20).

Caution: Pawl lever (A5) must not touch the carrier as otherwise the piston will be disengaged. Danger of accident!

9.3 Screw in ring screw into piston, attach pile rope to it and raise piston approx. 5 cm (2"). Push down pawl lever (A5) by hand lower piston far enough so that all piston ring can be reached easily.

9.4 Exchange piston rings only by means of the piston ring installing pliers (to be found in tool box). Apply special grease.

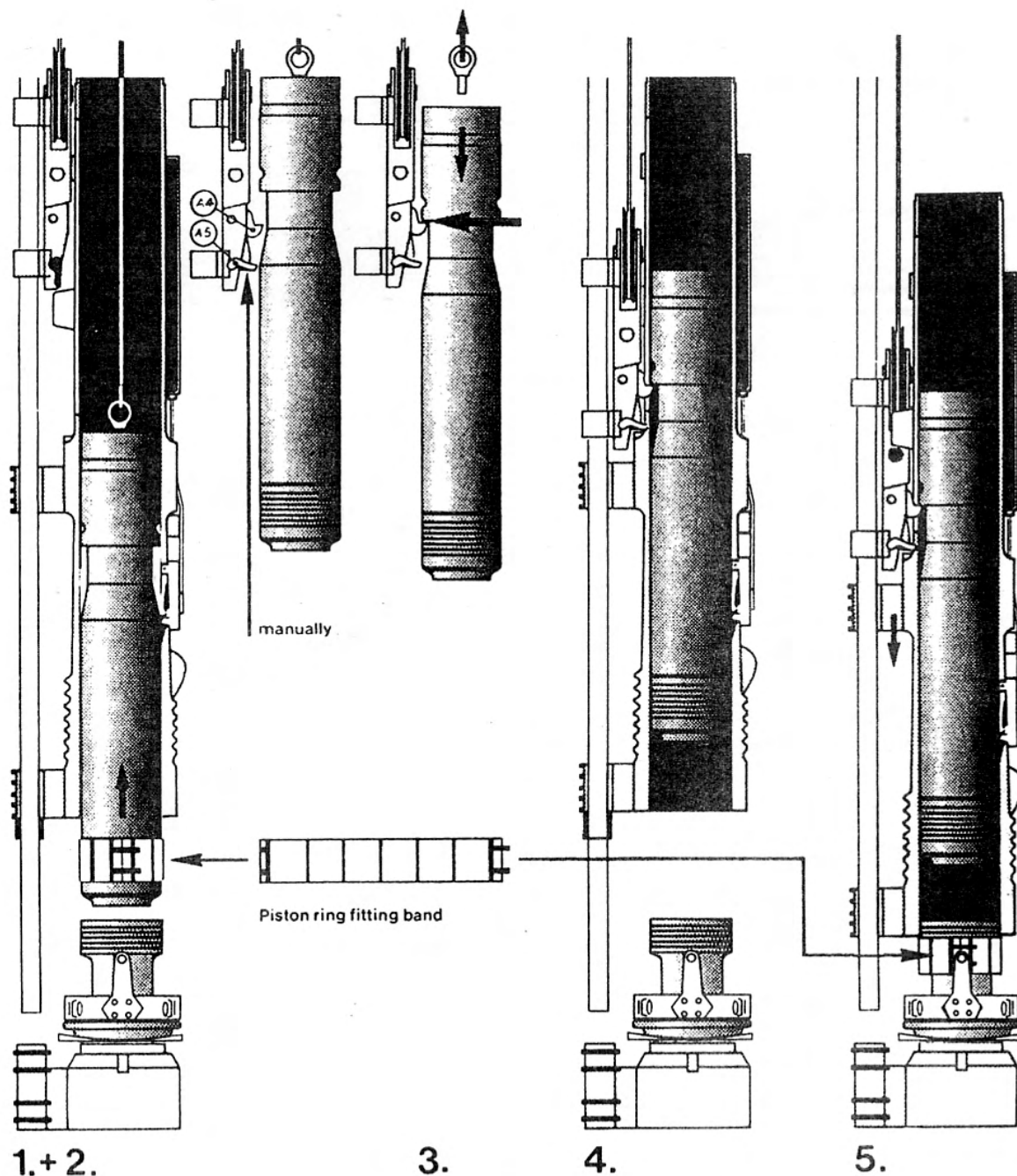

**10) Assembly**

10.1 Apply piston ring installing band.

10.2 Raise piston carefully until pawl (A4) can be inserted into piston groove by pressing the pawl lever upwards. Hold piston ring installing band in place to prevent it sliding down when piston slides into the cylinder.

10.3 Set down piston onto pawl remove pile rope and ring screw.

10.4 Lower piston by means of the trip gear down to the lower carrier.

10.5 Place piston ring installing band around impact block. Slightly raise hammer and remove catch fork. Then slowly lower over the impact block. Watch out that the piston ring installing band is not tossed on the cylinder end ring. Stop downward movement in time. Take-off installing band.

10.6 Fit inner rubber ring.

10.7 Set down cylinder lower part on cylinder end ring. Screw in assembly bolts.

10.8 Raise hammer so that cylinder end ring can be screwed on

10.9 Take off assembly plates. Place two-part rubber ring on impact block flange. Lower hammer and press rubber ring into the dovetailed groove.

10.10 Fit impact block securing clamp. Remove wedges from underneath the impact block.

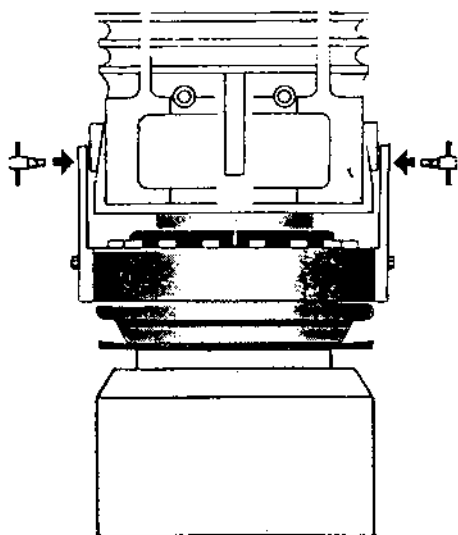

6.+7.

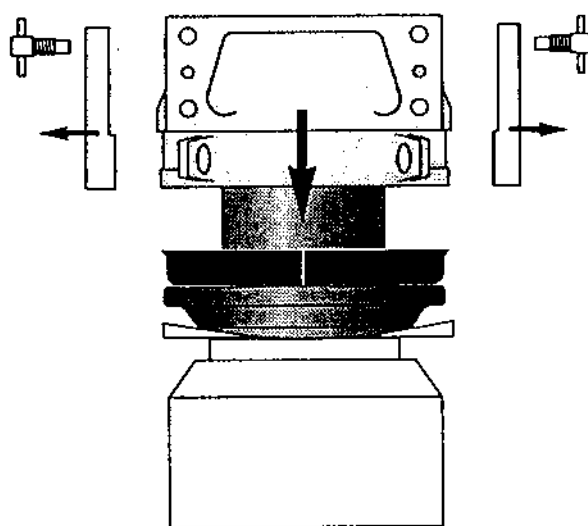

9.+10.

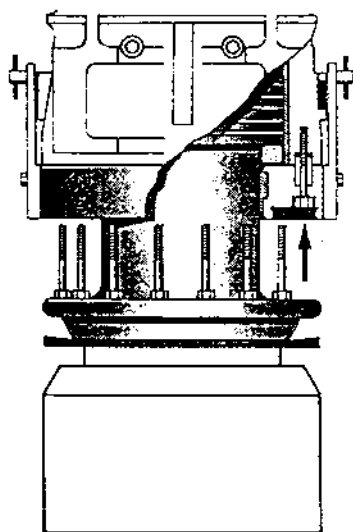

8.

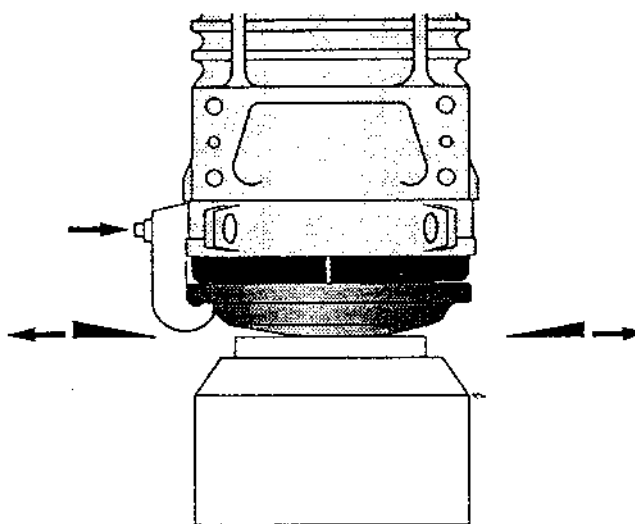

## Safety regulations

### Please observe all locally applicable safety regulations

The following is a list of accident prevention regulations covering pile-driving work on the Federal Republic of Germany:

**1) Accident Prevention Regulations for pile driving, VBG 41.**

**2) Rope-desiring Regulation: DIN 1 5020.Sheet 2 or VD1 Guide line 2358.**

### **3) Securing the pile hammer**

**Through one of the following methods:**

3.1 By locking on lead or

3.2 By lowering on lo supports built into the lead

If the law does not stipulate a particular method of securing the pile hammer, it must be secured by other means e.g. a “bridle” to prevent it from falling.

3.3 Bridle in piston

3.4 Bridle when not in use for lifting the pile hammer.

### **4) Safety Precautions for Personnel**

Always wear a safety helmet. When-pile driving, also wear ear muffs. If necessary, wear protective gloves and footwear with non-slip soles. Before mounting the lead always put on the safety harness and hook it up to the guy rope of the fall prevention device. When working over water wear a life-jacket.

### **5) Fall prevention Device (for personnel)**

**Compulsory for leads more than 5m long.**

Attach the device at a suitable point or at the point specified by the manufacturer of the lead.

Hook the perlon rope supplied onto the snap hook on the fall prevention device. Attach the other end to the base of tile lead.

When required, pull the guy rope, put on the safety harness and attach the snap hood to it. Under no circumstances should the guy rope remain attached to the base of the lead for prolonged periods, since this may weaken the rope-coiling mechanism. Periodic inspections of the device must be carried out in accordance with the regulations of the responsible authority.

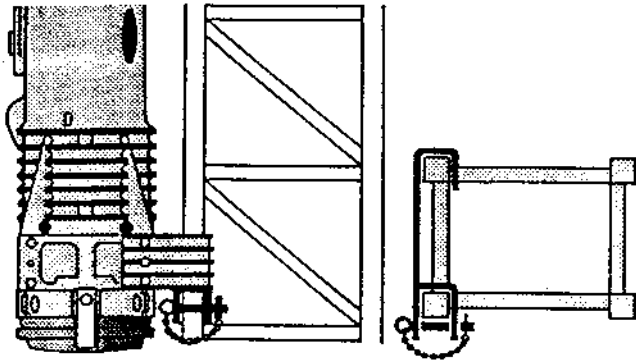

3.1

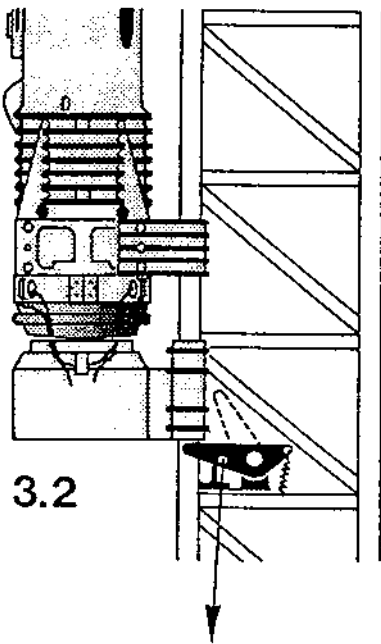

3.2

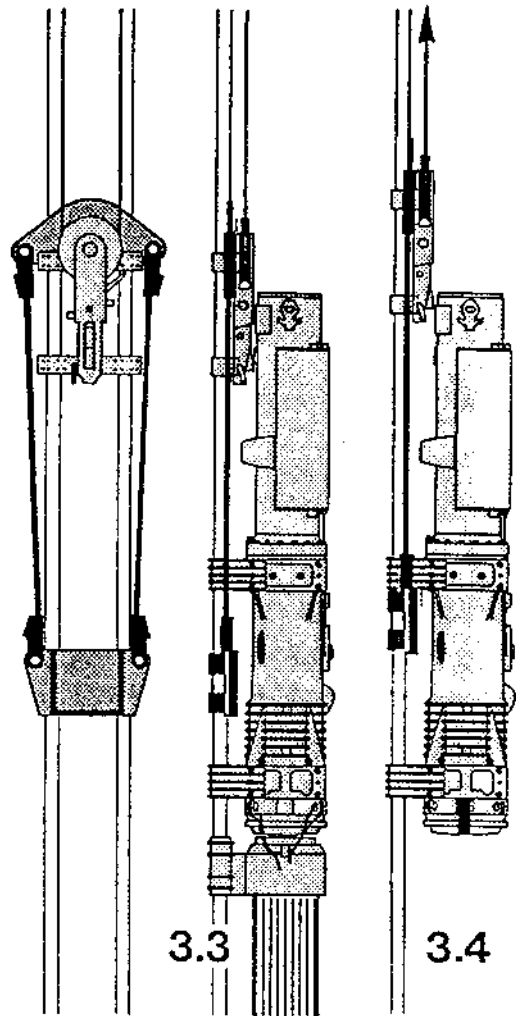

3.3

3.4

### Screw or bolt tightening torque

①	Cylinder end ring	Nm/lb-ft	3000/2200
②	Cylinder lower part	Nm/lb-ft	3000/2200
③	Variable delivery fuel pump	Nm/lb-ft	280/206
	Lube oil pump Injection valve cover		
④	Guide clamps	Nm/lb-ft	3000/2200
⑤	Guide gibs (trip gear)	Nm/lb-ft	600/440

