



DIESEL HAMMERS

D5-43 through D100-13

Operating Instructions

APE - American Piledriving Equipment, INC.

7032 South 196th St. Kent,

WA 98032 USA

(800) 248-8498

(253) 872-0141

www.apevibro.com

WARNING

**DO NOT LET TRIP
REST ON CARRIERS
WHILE HAMMER IS
RUNNING**

Attach warning notice supplied with hammer in good visible position in drivers cabin.

DANGER

**LIFT HAMMER WITH THE TRIP GEAR AGAINST
THE CARRIER ONLY AS DESCRIBED IN OPERATING
MANUAL.**

**DO NOT LIFT TRIP GEAR AGAINST TOP OF
STARTER-GUIDES.**

**‘WARNING: DO NOT LEFT TRIP REST ON CARRIERS
WHILE HAMMER IS OPERATING’**

**NEVER PLACE ANY PART OF THE BODY UNDERNEATH
THE HAMMER**

ALWAYS SECURE HAMMER BEFORE MOVING LEADS

Attach warning notice supplied with hammer in good visible position on piling rig.

DANGER

**NEVER PLACE ANY PART OF THE
BODY UNDERNEATH THE HAMMER.
SERIOUS INJURY MAY RESULT.
SECURE HAMMER BEFORE
MOVING LEADS.**

Attach warning notice supplied with hammer in good visible position on piling rig.

Table of contents

1. Table of Contents

0. General Information	0-2
Prior to assembly	0-3
Warning Signs	0-4
1. Table of Contents	1-1
2. Information on these Operating Instructions	2-1
2.1 Safety Indicators	2-1
3. Safety Information	3-1
3.1 Scope	3-1
3.2 Proper and improper use	3-1
3.3 Work places	3-1
3.4 General safety information for the handling of the pile hammer	3-2
3.5 Safety information for the excavator operator	3-5
3.6 Safety information for the operator	3-6
3.7 Safety information for the foreman in charge of the pile-driving work	3-6
3.8 Assembly, conversion, disassembly, maintenance, repairs	3-7
3.9 Applicable regulations and standards	3-8
3.10 Warning signs and their locations	3-8
3.11 Danger list	3-9
4. Technical Data	4-1
Conversion factors	4-1
Sound emission values	4-2
Technical Data (American units)	4-4
Technical Data (metric units)	4-6
5. Transport	5-1
5.1 Transport	5-1
5.2 Transport cables	5-3
Possible cable damage	5-4
5.3 Lifting with the lifting equipment	5-5
6. Assembly and mode of operation	6-1
6.1 Components of Diesel pile hammer D 5-43 through D 6-32	6-1
6.2 Components of Diesel pile hammer D 8-22	6-2
6.3 Components of Diesel pile hammer D 12-32	6-3
6.4 Components of Diesel pile hammer D 16-32 and D 19-42	6-4
6.5 Components of Diesel pile hammer D 25-32/33 and D 30-32/33	6-5
6.6 Components of Diesel pile hammer D 36-32/33 and D 46-32/33	6-6
6.7 Components of Diesel pile hammer D 62-22	6-7
6.8 Components of Diesel pile hammer D 80-23 and D 100-13	6-8
6.9 Longitudinal section	6-9
6.10 Operating mode of the Diesel pile hammer	6-10

Table of contents

7. Assembly and conversion	7-1
7.1 Guiding possibilities	7-1
Guiding in front of the lead	7-1
Guiding inside cable-suspended lead	7-2
Guiding in the U-type lead	7-4
Guiding in the Dutch-type lead	7-4
7.2 Conversion for the driving of batter piles	7-5
Blow energy for the driving of batter piles	7-6
7.3 Assembly and disassembly of the cylinder extension	7-7
7.4 Installation of safety devices	7-8
Height-safety device	7-8
Support device	7-9
Bridle	7-10
7.5 Piston replacement	7-11
8. Putting into operation	8-1
8.1 Filling lubricant lines with oil	8-1
8.2 Assembly of pile helmet cushions	8-2
8.3 Guiding for pile helmet	8-3
8.4 Bringing into operating position of pile hammer and pile helmet	8-4
8.5 Lifting of piles	8-6
8.6 Tripping device	8-9
Assembly	8-9
Operational test	8-10
8.7 Fuel supply control	8-12
Operational test	8-12
Bleeding of fuel control pump and injection valves	8-13
8.8 Cleaning of combustion chamber	8-14
8.9 Start and control	8-15
9. Operation	9-1
9.1 Pile driving	9-1
Blow area	9-2
Shutoff	9-3
9.2 Blow energy stages	9-3
10. Shutting down and storage	10-1
10.1 Shutting down and leaving in lead	10-1
10.2 Removal from lead	10-2
10.3 Storage	10-4
Laying-up	10-5
11. Maintenance	11-1

Table of contents

12. Servicing and trouble shooting	12-1
12.1 Trouble shooting	12-1
12.2 Screwed/Bolted connections	12-5
12.3 Guiding devices	12-6
12.4 Tripping device	12-7
Operational test	12-8
12.5 Pumps	12-9
Disassembly and cleaning of pumps	12-9
Lubricant pump	12-9
Fuel control pump	12-10
12.6 Filter	12-11
12.7 Grease nipple	12-12
12.8 Catch groove and piston catch ring	12-12
12.9 Damp rings	12-13
12.10 Piston and impact block rings	12-15
12.11 Compression	12-20
12.12 Steel cables	12-21
Placing and rolling off	12-21
Cable care	12-21

Appendices

A 1 EC Conformity Statement	A1-1
A 2 Accessories	A2-1
Other-starting device for Diesel pile hammers	A2-1
Test stand for fuel control pump	A2-3
Lead profiles, standard distances to the Diesel pile hammer	A2-5
A 3 Summaries and calculation aids	A3-1
Applicable fuel types	A3-1
Reduction factors for different pile helmet cushions	A3-3
Correlation between number of blows and drop height	A3-4
Accessories for Diesel pile hammer	A3-6
Saximeter	A3-7
Sources	A3-8
Summary of pile hammer types	A3-9
A 4 Form “Operating instructions were read and understood”	A4-1

Information on these operating instructions

2. Information on these operating instructions

These operating instructions

- must be used by anyone who assembles, converts, disassembles, operates, maintains or repairs a Diesel pile hammer of the type D5-43 through D100-13 manufactured by APE,
- simplify all work in connection with a Diesel pile hammer,
- inform you about some basics of the operating mode and use of Diesel pile hammers,
- help you with the required calculations,
- contain important information for the safe and proper handling and operation of the Diesel pile hammer.

2.1 Safety indicators

The following symbols are used in these operating instructions:



Immediate danger to life and limb!



A possibly dangerous situation to life and limb!



Dangerous situation! Possibly minor injuries and property damage!

Please read these operating instructions carefully. The safety information must be observed!

General and special safety information is contained in Chapter 3 "Safety Regulations". Safety information relating to a specific handling step is shown prior to the description of this handling step.



Danger

3. Safety regulations

3.1 Scope

The general safety information (Chapter 3.4) applies equally to supervisors (e.g., the foreman in charge of the pile-driving work), user, operator, instructor, excavator operator as well as to the workers that assemble, convert, disassemble, maintain and repair the Diesel pile hammers. In addition, other safety information given in this chapter at the beginning of the description of the activity must be observed by certain workers and for certain activities.

The safety information is provided to keep the risk for workers and property as low as possible!

3.2 Proper and improper use

The proper use of Diesel pile hammers is defined as the driving of suitable units into a supporting soil layer. Said units may be piles, pipes, sheet piles etc. that will not be destroyed by the impact forces applied by the Diesel pile hammer.

All other uses such as the deforming or compacting of materials or the removal of piles constitute an improper use and are thus not permitted for safety reasons! Danger to life!

3.3 Work places

Work place 1: Excavator operator

- Works in the cabin of an excavator/crane/ship or of a similar suitable means of transport.
- Is responsible for the moving of the means of transport as well as for the positioning and starting of the Diesel pile hammer.
- Must follow the instructions given by the foreman in charge of the pile-driving work.

Work place 2: Operator

- Must keep a minimum distance of 13 feet (4 meters) from the units to be driven.
- Is responsible for the control of the number of blows (by way of the fuel supply) as well as for the shutting-off of the pile driving.
- Must follow the instructions given by the foreman in charge of the pile-driving work.

Work place 3: Foreman in charge of the pile-driving work

- Must keep a minimum distance of 13 feet (4 meters) from the units to be driven.
- Is responsible for the training of the operator and excavator operator, for the monitoring of the pile-driving work, the observing of the operating instructions and the maintaining of the work protocol.
- Must establish signals prior to the work, with which instructions will be given to the excavator operator and the operator.



Danger

3.4 General safety information for the handling of the Diesel pile hammer

Safety is basically a matter of common sense! There are safety regulations that must be observed at all times! Beyond that, each situation exhibits peculiarities that cannot always be indicated in the safety regulations! Always watch for safety risks and problems! Plan ahead and take care of problems as early as possible!

Please keep these operating instructions for Diesel pile hammers with the documents for the carrier equipment! Keep both at an easily accessible location! Inform the operators regarding the obligation to read these operating instructions and about the location where documentation is kept!

You must read every page of these operating instructions prior to handling the Diesel pile hammer. Observe the safety information and instructions contained in these operating instructions when working with the Diesel pile hammer. A lack of the above may endanger your life and that of other persons! Prior to the work, all persons that will work with the pile hammer must indicate in the form of the Appendix (A4) that they have read and understood the operating instructions!

The Diesel pile hammer shall be inspected prior to the first time that it is put into operation and then annually by an expert! Said thorough inspection must be carried out by persons that have participated in an extensive training program in our facilities. Such an expert inspection is also required after any structural change! The results of the inspection must be indicated in writing!

Prior to putting the unit into operation, it will be necessary to determine if the last expert inspection was carried out within the last 12 months! The Diesel pile hammer cannot be operated otherwise!

Only properly trained and authorized personnel shall work with the diesel pile hammer!

You must observe local safety regulations issued by the respective legislature or by unions and similar organizations! Take the necessary measures with respect to sound and vibration emissions occurring during the operation of the Diesel pile hammer.

The pamphlet "Earth-moving equipment" published by the civil engineering association forms a part of the operating instructions for the carrier equipment. The safety-technical requirements described in this pamphlet must also be observed for the Diesel pile hammer! Ask the job site manager regarding special safety regulations and warning signs for the job site! When working with the Diesel pile hammer, it is also necessary to observe the accident prevention regulations issued by trade unions, particularly the

- VGB 1 "General Regulations",
- VGB 40 "Excavators, loaders ... and special equipment used for earthwork",



Danger

- VGB41 “Driving of piles” and
- No. 316 “Safety regulations for work platforms on driving and drilling equipment”.

DIN 15020, Sheet 2, shall be observed when taking off the steel cables.

Obstacles in the work and transport areas, the load capacity of the soil as well as safety barriers for public traffic areas must be taken into account. It is particularly important to pay attention to changing weather conditions, wind, decreasing visibility and changing soil conditions! Stop work for critical conditions (e.g., storms!). Visibility must be sufficient to allow a proper operation of the pile-driving equipment by driver and operator without risking their lives and that of others! Lights must be used for work carried out under poor visibility conditions or in darkness! The lighting fixtures must provide a brightness of at least 100 lx for the work areas! For transports in darkness, moving equipment must be fitted with lights providing a distance light level of at least 10 lx (23 feet (7 meters) ahead of the equipment measured in the driving direction)! Keep a safe distance from

- High-voltage overhead lines, phone lines and other overhead lines;
- Earth cables, water pipes, sewage water pipes and other pipes located below ground;
- Overhangs, edges, slopes and unsafe soil!

Prior to beginning your work, ask the superintendent

about the location of supply and disposal pipes and about the safe distances to be maintained! Danger to life!

All workers must be healthy and strong enough to meet the physical challenges! Under no circumstances shall a worker be allowed to work under the influence of drugs, alcohol, medications or similar!

Hard hat, safety gloves, safety boots and suitable work clothes must be worn at all times when working with the Diesel pile hammer. Reflective clothing shall be worn if conditions warrant this! This reduces the risk of injuries! Ear plugs should also be worn when operating the Diesel pile hammer! A permanent hearing impairment may result otherwise (See Chapter 4 “Technical Specifications” for Sound Emission Data).

The pile hammer must be fitted with at least two fire extinguishers! The fire extinguishers

- must have a minimum capacity of 13 pounds (6 kg),
- must be suited to extinguish oil and electric fires,
- must be placed on the same side of the pile-driving equipment
- shall not be placed in areas exposed to a high fire risk,
- must be placed as close as possible to the operator and between the operator and the area with the greatest fire risk (at a very visible and easily accessible location for remote-controlled Diesel pile hammers),



Danger

- must be attached such that they can be removed without tools!

Familiarize yourself with the location and handling of the fire extinguishers prior to beginning work!

Maintain a minimum safe distance of 13 feet (4 meters) from the units to be driven during the operation of the Diesel pile hammer! Make sure that only the excavator operator, operator and the foreman in charge of the pile-driving work move within an area of 1.5 times the lead height (or the height of the excavator/crane)! Close this area off, if required!

Please note that a mixture of fuel, exhaust gas, soot and air is at a high pressure blown out of the combustion chamber bolt opening when cleaning the combustion chamber! Maintain a safe distance and wear safety goggles! Danger of injuries!

Do not touch the Diesel pile hammer immediately after its operation! Danger of burns! Particularly the impact head, exhaust and components located adjacent to the combustion chamber must be allowed to cool for a sufficient period!

Diesel fuel, ether and lubricants are very flammable and can explode under certain conditions! Diesel fuel, ether and lubricants must be handled carefully! Take appropriate measures to prevent a spilling, igniting, inhalation, swallowing as well as skin or eye contact with Diesel fuel, ether or lubricants! The work area of the Diesel pile hammer must always be well ventilated! Under no circumstances will smoking or other activities with open flames or sparks be allowed during fueling or in storage areas of Diesel fuel, ether and lubricants! Diesel fuel, ether and lubricants should never be stored in foodstuff containers! Danger to health (poisonous, caustic) and the environment!

Exhaust gases forming during operation are poisonous! Do not inhale exhaust gas! Danger to health!

Work on a Diesel pile hammer (maintenance, repair, converting ...) shall only be carried out with a turned-off Diesel pile hammer! The Diesel pile hammer must rest on the pile or ground or on the lower support device!

Avoid touching moving parts! Danger of crushing!

Pay careful attention at any time for components that come loose and fall from the Diesel pile hammer, lead, impact head, pile guiding system or from the pile itself!

Keep the job site tidy! Danger of injuries!



Danger

3.5 Safety information for the excavator operator

Use only excavators/leads/cranes that exhibit a sufficient load capacity for the Diesel pile hammer, pile helmet and the piles!

Make sure the accessories are safely stored away prior to converting the equipment! Secure all loose components! Keep the load as close as possible to the ground during the conversion stage! Drive very carefully on a rocky or slippery ground or on a slope!

You must personally make sure that nobody will be placed into a dangerous situation with the moving of the equipment! Seek the assistance of a helper! Accept signals from one person only! No co-driver, please!

Lights must be turned on in darkness or in low visibility conditions!

Observe traffic signs and rules when driving on public traffic areas!

Do not hold on to the steering wheel column, control console or operating levers when entering or leaving the vehicle! This may cause accidental motions! Danger of accidents!

Always work up or down a slope and not laterally to the slope! Prevent any actions that could cause the equipment to overturn! When the equipment nevertheless begins to overturn or slide laterally, it will be necessary to immediately lower the equipment and point the vehicle down the slope!

Never exceed the maximum speed on a down slope! Always change -to a lower gear prior to reaching the down slope! You may lose control of the vehicle otherwise!

Never leave the driver's seat when the vehicle is still moving or the Diesel pile hammer is still in operation! Never leave the vehicle unattended with the motor running!

You must or must not do the following when you come into contact with a power line carrying a high voltage:

- Do not leave the vehicle.
- Drive the vehicle out of the danger zone, if possible.
- Warn other persons not to come closer to or touch the equipment.
- Arrange for the power to be turned off.
- Leave the vehicle only after the power has been turned off!

Familiarize yourself with the emergency exit through the front window!

Report all problems to the foreman in charge of the pile-driving work. Make sure the necessary repairs are carried out immediately!

Check the steel cables daily for wear in accordance with DIN 1520, Sheet 2 (See Section 12.12 "Steel Cables" and Chapter 5.2 "Transport Cables"! Have worn and damaged cables replaced immediately!



Danger

3.6 Safety information for the operator

Wear a hard hat, safety boots, safety gloves, ear plugs, safety goggles and suitable, possibly reflecting, work clothes when working with the Diesel pile hammer! This reduces the risk of injuries and prevents permanent hearing and eye damage!

Familiarize yourself with the operating instructions for the Diesel pile hammer and all of its accessories prior to putting the unit into operation! Make sure you have a complete set of operating instructions!

The Diesel pile hammer shall be operated only by trained personnel that have been authorized by the foreman in charge of the driving work!

Operate the Diesel pile hammer only when it is in a technically perfect condition! Carry out a thorough inspection prior to putting the equipment into operation! Make sure all warning signs are placed and easy to read (See Chapter 3.10 “Warning signs and their location”)! Do not operate a Diesel pile hammer that is damaged or exhibits operating problems! Inform the foreman in charge of the pile-driving work about damages! All problems must be remedied prior to putting the equipment into operation (e.g., by attaching a sign stating “Warning; Diesel pile hammer is out of order!; such a sign is included in the tool box, see Chapter 3.10 “Warning Signs and their location”)!)

You must take into account that the operation of the Diesel pile hammer causes blows, impact forces and vibrations in the whole pile hammer structure and in the immediate vicinity!

Never work under the Diesel pile hammer, lead or material to be driven! Avoid standing in the

area, in which the material to be driven touches the ground!

Make sure repairs are carried out only by trained experts!

3.7 Safety information for the foreman in charge of the pile-driving work

The foreman in charge of the pile-driving work must have been trained with this unit and must be at least 18 years old! Provide the operator and excavator operator with information ensuring a safe execution of the work! You are responsible for safety and all events in the work area of the Diesel pile hammer!

Please familiarize yourself with the operating instructions for the Diesel pile hammer and all of its accessories prior to putting the equipment into operation!

Make sure your operating instructions are complete!

Make sure the equipment and associated attached units are inspected daily for obvious defects prior to putting them into operation! Make sure all warning signs are placed and readable (See Chapter 3.10 “Warning signs and their location”)! Defects are found most often in the following components:

- Diesel pile hammer
- Tripping device
- Guiding components
- Support devices
- Pile helmet and pile guiding system
- Bridle and cables



Danger

The pile-driving work cannot be resumed with a defective unit! Inform the pile-driving personnel and the superintendent about the defects! Have the defects remedied prior to putting the equipment into operation! Make sure only properly trained experts carry out repair work! Do not operate the equipment until all defects have been fully remedied (e.g., by attaching a sign stating “Warning; Diesel pile hammer is out of order!; such a sign is included in the tool box, see Chapter 3.10 “Warning Signs and their location”)! Carry out a thorough inspection prior to putting the unit into operation.

Prior to putting the equipment into operation, you must make sure that nobody is on or below the equipment. Sound the horn to warn persons of the impending putting into operation of the pile hammer!

You must take into account that the operation of the Diesel pile hammer causes blows, impact forces and vibrations in the whole pile hammer structure and in the immediate vicinity!

Never work under the Diesel pile hammer, lead or material to be driven! Avoid standing in the area, in which the material to be driven touches the ground!

3.8 Assembly, conversion, disassembly, maintenance, repair

The Diesel pile hammer shall be inspected prior to the first time that it is put into operation and then annually by an expert! Said expert inspection must be carried out by persons that have participated in an extensive training program in our facilities.

Assembly, conversion, disassembly, maintenance and repair work shall be carried out only by qualified and authorized experts!

The Diesel pile hammer must be shut off prior to carrying out any work on it! Danger to life!

Make sure another person cannot put the equipment into operation when work is carried out! Danger to life!

The following must be observed for repair and maintenance work.

- At least two persons must be present. Both must be familiar with the operating instructions and must know how to address safety questions!
- One person must be located at the main operating station to monitor the safety of the other persons! Said person must have access to an EMERGENCY switch (or shutoff cable for the fuel supply) in all situations!
- An uninterrupted communication must be possible between the involved persons!
- The work area must be fully lighted!

Maintenance and repair work can be carried out by one person only, when the pile hammer is completely shut off and all means to put it into operation are blocked!



Danger

3.9 Applicable regulations and standards

- VGB 1 “General Regulations”;
- VGB 40 “Excavators, loaders... and special equipment used for earthwork”;
- VGB 41 “Driving of piles”;
- Pamphlet “Earth-moving equipment” issued by the civil engineering association;
- Trade union publication No. 316 “Safety regulations for work platforms on driving and drilling equipment”.
- DIN 15020, Sheet 2, “Basic information on cable drives”;
- Safety regulations that are applicable to the location of use and must be met as required by the respective legislature or trade unions or similar institutions;
- Special safety regulations and warning signs at the job site.

3.10 Warning signs and their location

- ① “Warning - Danger! Operate only with a fixed upper end ring!”
- ② Inspect all screwed/bolted connections daily! Tighten, if necessary!
- ③ Warning sign in accordance with DIN 4844 “Ear plugs must be worn!”
- ④ Do not get closer than 13 feet (4 meters) from the operating equipment!”
- ⑤ Warning: Diesel pile hammer is out of order!”

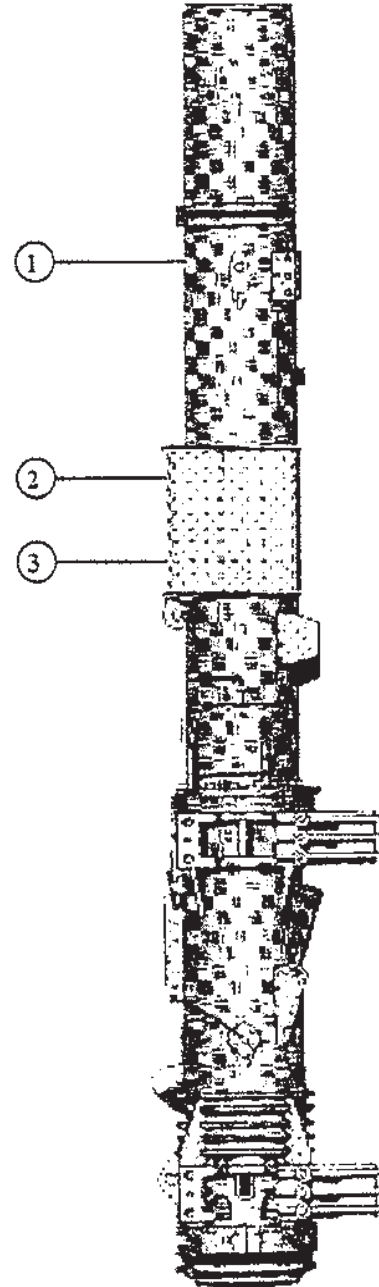

- ④ Is included with the tool box. Please place at a highly visible location on the carrier equipment!
- ⑤ Is included with the tool box. Please place at a highly visible location at the front of the unit, if required! Warning! Do not touch hot areas and do not put stickers on hot areas!



Danger

3.11 Danger list

To the extent they are addressed in the operating instructions, this list contains all dangers considered important for Diesel pile hammers and measures required to remove or reduce the risks. Dangerous situations can occur as indicated below:

- Transport to and from the place of use
- Assembly and disassembly on the job site
- Operation on the job site
- Conversion on the job site
- Shut off Diesel pile hammer on the job site
- Storage in job site parking area or at the place of use

Mechanical dangers

- Crushing, impact
- Shearing, cutting, cutting off
- Grasping, rolling on, rolling in, capturing
- Friction, wear
- Throwing out/escaping of components-fluids at a high pressure
- Loss of stability
- Sliding, tripping, falling

Electrical dangers

- Electric contact (direct or indirect)
- Outside effect on electric devices (power lines)

Thermal dangers

- Burns and scalding due to contact, flames or explosion as well as radiation from heat sources
- Health problems caused by a hot or cold work environment

Dangers caused by noise or vibration

- Hearing loss (deafness)
- Restricted oral communication, acoustic signals are hard to hear etc.
- Stresses caused by a vibration of the whole unit

Dangers caused by substance emissions

- Inhaling/swallowing of dangerous substances and gases
- Danger caused by fire or explosion

Dangers caused by neglecting ergonomical principles

- Unhealthy position or excessive stress
- Insufficient consideration of the human anatomy with regard to hand / arm or foot / leg
- Casual use of personal protection equipment
- Insufficient lighting
- Mental overstrain/understrain, stress
- Human error

Dangers caused by an energy supply failure, failure of equipment components and by other malfunctions

- Energy supply loss
- Throwing out/spraying out of components/fluids at a high pressure
- Failure/malfunction of control system
- Incorrect installation
- Overturning, unexpected loss of equipment stability

Dangers caused by lacking or incorrectly taken safety measures/equipment

- All types of separating protection and safety devices
- Starting equipment
- Safety symbols and signs
- All types of information or warning signs
- Switch-off devices
- Emergency measures
- Required equipment and accessories for a safe setup and maintenance

Combination of different dangers

Technical data - Conversion factors

4. Technical Data

The technical data are given in the data summary on page 4-4/5. Please note the following:

- Determine the Diesel pile hammer type you use from the inside front cover!
- Consider only those technical data shown in the column of the respective type.
- All weights and consumption data are rounded off. These data may differ slightly from the actual data.

Conversion Chart

1 t	=	1000 kg
1 kg	=	0,001 t
1 kg	=	2,2 lbs
1 lbs	=	0,4535 kg
1 kN	=	102 kp
1 kp	=	0,00981 kN
1 Nm	=	0,102 kpm
1 kpm	=	9,81 Nm
1 Nm	=	0,7376 ft.lbs
1 ft.lbs	=	1,356 Nm
1 mm	=	0,0394 in
1 in	=	25,4 mm
1 cm	=	0,394 in
1 in	=	2,54 cm
1 m	=	39,4 in
1 in	=	0,0254 m
1 m	=	3,2808 ft
1 ft	=	0,305 m
1 m	=	1,094 yd
1 yd	=	0,914 m
1 cm ²	=	0,155 in ²
1 in ²	=	6,452 cm ²
1 cm ³	=	0,061 in ³
1 in ³	=	16,39 cm ³
1 l	=	0,26 gal
1 gal	=	3,785 l

Technical data - Sound emission values

Sound emission data

Sound pressure level at a distance of 23 feet (7 meters) from the Diesel pile hammer

Type	Sound pressure level in dB(A)
D5-43	99
D6-32	
D8-22	100
D12-32	102
D16-32	106
D19-42	
D25-32	110
D25-33	
D30-32	
D30-33	111
D36-32	
D36-33	
D46-32	
D46-33	114
D62-22	
D80-23	116
D100-13	119

Sound pressure level as a function of the distance from the Diesel pile hammer

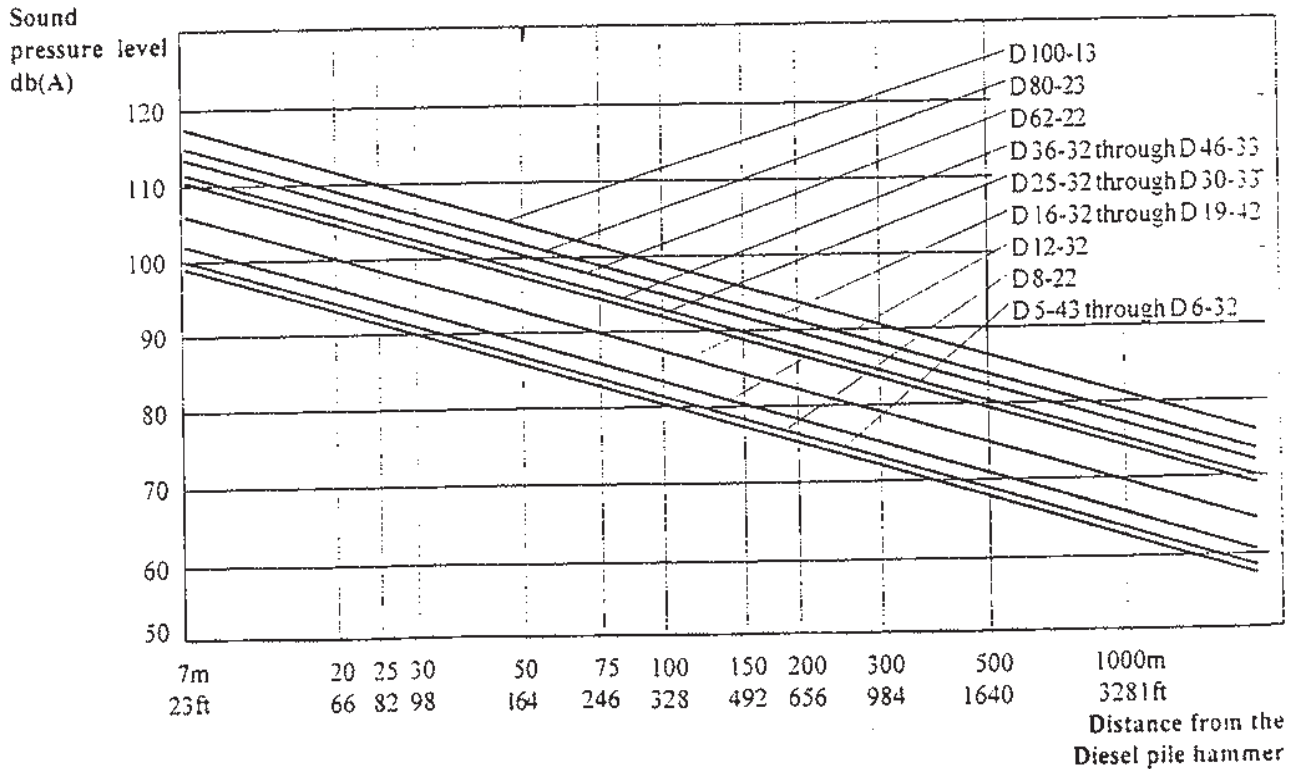

Technical data - American units

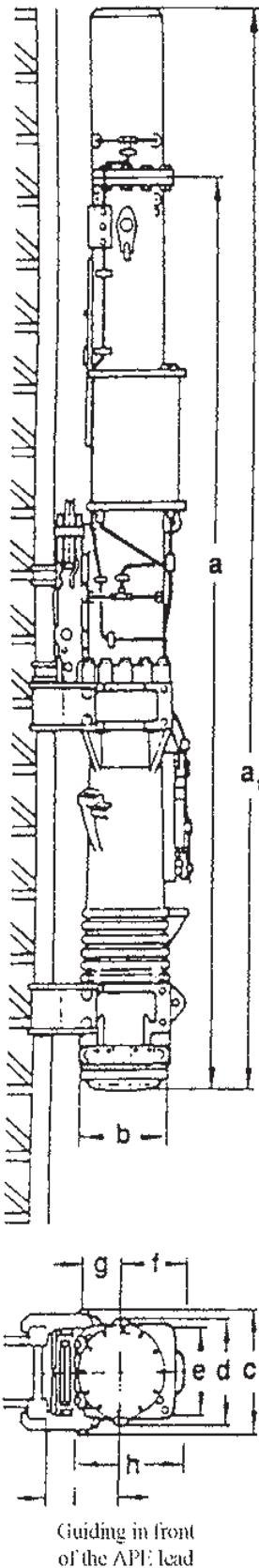

Diesel pile hammer type		D5-43	D6-32	D8-22	D12-32
Product No.		21202	21130	21052	21120
Max. batter for batter piles		1:3	1:3	1:2	1:2
Impact weight (piston)	lbs	1100	1320	1760	2816
Energy per blow	ft.lbs	10474-5900	12613-7092	17658-9434	31318-15121
Blows per minute		39-52	39-52	38-52	36-52
Explosion pressure force (max) on the material to be driven	kN (kp)	350 (35690)	505 (51500)	505 (51500)	606 (61810)
Suitable to drive material (As a function of soil and material to be driven)	t	0,2-1,5	0,3-2,0	0,5-3,0	0,8-4,5
Allowable max. cable diameter for the guide pulley of the tripping device	in	0,788)*	0,788)*	0,788)*	0,788)*
Consumption					
Diesel	gal/hr	0,65	0,96	1,04	1,17
Lubricant	gal/hr	0,06	0,06	0,13	0,13
Capacity for vertical driving					
Diesel tank	gal	4,7	4,9	5,2	6,2
Lubricant tank	gal	1,3	1,3	1,5	1,6
Ether tank	gal	0,26	0,26	0,26	0,26
Weights					
Diesel pile hammer with piston etc.	lbs	3080	3564	4257	6017
Tripping device approx.	lbs	220	220	220	220
----	----	----	----	----	----
----	----	----	----	----	----
----	----	----	----	----	----
----	----	----	----	----	----
Transport angle approx.	lbs	24,2	24,2	24,2	24,2
Transport protection approx.	lbs	33	33	33	33
Tool chest approx.	lbs	165	165	165	165
Dimensions					
a/ Length of Diesel pile hammer without extension					
a, with extension	in	169,42	169,42	185,18	185,96
b Outside diameter of the impact section	in	13,39	13,79	13,79	15,76
c Width of guiding shoes, including fastener	mm	22,06	22,06	22,06	22,06
d Width of Diesel pile hammer					
without guiding parts	in	13,79	18,32	16,15	17,33
e Width for guiding - face to face	in	12,61	12,61	12,61	12,61
f Hammer center to pump guard	in	12,02	12,21	12,41	13,20
g Hammer center to bolt center	in	9,65	9,65	9,65	9,65
h Hammer depth overall	in	22,85	23,24	23,24	24,03
Min. dimension from hammer center to lead (see page A2-5)	14,18 in	14,18 at Profile 2	14,18 at Profile 2	13,79 at Profile 2	13,39 at Profile 2

)* Standard tripping device is supplied without guide pulley. Guide pulley is available, when sheaving is required.

)** 2 Guide pulleys available

Technical data - American units

D16-32 21051		D19-42 21191		D25-32/33 21060/63		D30-32/33 21070/73		D36-32/33 21080/85		D46-32/33 21090/86		D62-22 21040		D80-23 21041		D100-13 21100			
1:5	1:1	1:5	1:1	1:5	1:1	1:5	1:1	1:5	1:1	1:5	1:1	1:5	1:1	1:5	1:1	1:5	1:2		
3520		4004		5500		6600		7920		10120		13640		17600		22000			
39366- 19621		48325- 24135		58248- 29485		69898- 35382		83880- 40900		107177- 52259		161505- 78960		196814- 126192		246019- 157743			
36-52		35-52		37-52		37-52		37-53		37-53		35-50		36-45		36-45			
686 (69950)		686 (69950)		1304 (132960)		1304 (132960)		1695 (172830)		1695 (172830)		1800 (183485)		2600 (265035)		2600 (265035)			
1.0-6.0		1.1-6.6		1.6-7.5		2.0-9.0		2.5-12.0		3-16		4-30		6-60		7-100			
0,788)*		0,788)*		0,867)*		0,867)*		1,497)*		1,497)*		1,497)*		1,182)**		1,182)**			
1.9		1.3		2.08		2.6		3.0		4.16		5.2		6.5		7.8			
0.13		0.13		0.26		0.26		0.39		0.39		0.52		0.67		0.67			
8.3		8.3		17.4		17.4		23.1		23.1		25.5		40.3		40.3			
2.3		2.3		4.9		4.9		4.4		4.4		8.2		8.3		8.3			
0.31		0.31		0.44		0.44		0.39		0.39		0.39		0.26		0.26			
7326	7645	7810	8129	12166	12782	13266	13882	17578	18480	19778	20680	26708	27610	36003	37191	44396	45584		
220		220		396		396		880		880		880		1650		1650			
---		---		---		---		---		---		---		---		---			
---		---		---		---		---		---		---		---		---			
---		---		---		---		---		---		---		---		---			
---		---		---		---		---		---		---		---		---			
24.2		24.2		44		44		44		44		158.4		297		297			
33		33		50.6		50.6		55		55		74.8		484		484			
165		165		220		220		220		220		275		275		275			
190.5		224.0		214.7		246.6		214.7		246.6		215.5		247.6		215.5		247.6	
232.8		272.2		244.3		283.7		250.5		289.9		27.97		32.31		32.31			
22.06		22.06		30.73		30.73		34.67		34.67		32.62		43.73		43.73			
19.11		19.11		25.21		25.21		30.93		30.93		31.52		35.06		35.06			
12.61		12.61		21.27		21.27		25.21		25.21		22.06		31.52		31.52			
13.59		13.59		15.95		15.95		17.53		17.53		19.30		21.67		21.67			
11.03		11.03		9.26		9.26		10.83		10.83		14.97		13.79		13.79			
26.20		26.20		28.17		28.17		33.41		33.41		38.21		43.73		43.73			
13.39 at Profile 2		13.39 at Profile 2		17.33 at Profile 3		17.33 at Profile 3		19.7 at Profile 4		19.7 at Profile 4		19.7 at Profile 5+7		26.00 at Profile 5+7		26.00 at Profile 5+7			

Technical data - Metric units

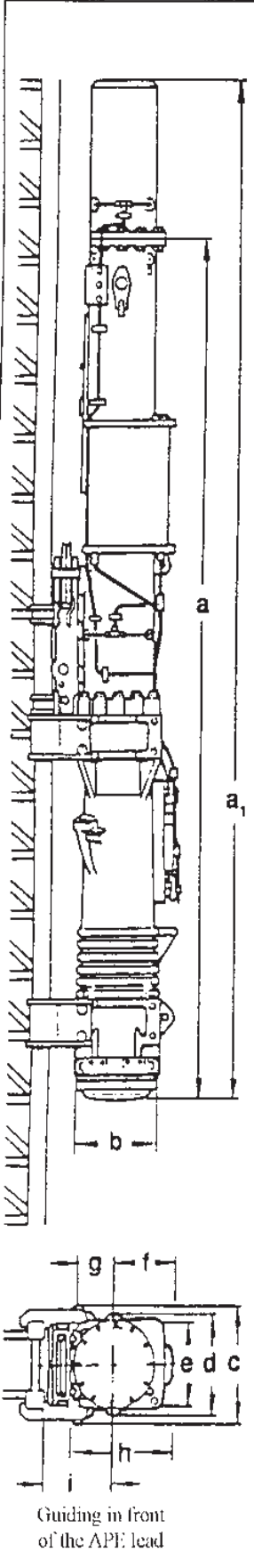

Diesel pile hammer type		D5-43	D6-32	D8-22	D12-32
Product No.		21202	21130	21052	21120
Max. batter for batter piles		1:3	1:3	1:2	1:2
Impact weight (piston)	kg	500	600	800	1280
Energy per blow	Nm	14200-8000	17100-9615	23940-12790	42460-20500
Blows per minute	l/min	39-52	39-52	38-52	36-52
Explosion pressure force (max) on the material to be driven	kN (kp)	350 (35690)	505 (51500)	505 (51500)	606 (61810)
Suitable to drive material (As a function of soil and material to be driven)	t	0,2-1,5	0,3-2,0	0,5-3,0	0,8-4,5
Allowable max. cable diameter for the guide pulley of the tripping device	mm	20)*	20)*	20)*	20)*
Consumption					
Diesel	l/h	2,5	3,7	4,0	4,5
Lubricant	l/h	0,25	0,25	0,5	0,5
Capacity for vertical driving					
Diesel tank	l	18	19	20	24
Lubricant tank	l	5,0	5,0	6,0	6,5
Ether tank	l	1,0	1,0	1,0	1,0
Weights					
Diesel pile hammer with piston etc.	kg	1400	1620	1935	2735
Tripping device approx.	kg	100	100	100	100
-----	-----	-----	-----	-----	-----
-----	-----	-----	-----	-----	-----
-----	-----	-----	-----	-----	-----
-----	-----	-----	-----	-----	-----
-----	-----	-----	-----	-----	-----
Transport angle approx.	kg	11	11	11	11
Transport protection approx.	kg	15	15	15	15
Tool chest approx.	kg	75	75	75	75
Dimensions					
a/ Length of Diesel pile hammer without extension/					
a ₁ with extension	mm	4300	4300	4700	4720
b Outside diameter of the impact section	mm	340	350	350	400
c Width of guiding shoes, including fastener	mm	560	560	560	560
d Width of Diesel pile hammer					
without guiding parts	mm	350	465	410	440
e Width for guiding - face to face	mm	320	320	320	320
f Hammer center to pump guard	mm	305	310	315	335
g Hammer center to bolt center	mm	245	245	245	245
h Hammer depth overall	mm	580	590	590	610
i Min. dimension from hammer center to lead	mm	360	360	320	340
		at Profile 2	at Profile 2	at Profile 2	at Profile 2

)* Standard tripping device is supplied without guide pulley. Guide pulley is available, when sheaving is required.

)** 2 Guide pulleys available*

Technical data - Metric units

D16-32		D19-42		D25-32/33		D30-32/33		D36-32/33		D46-32/33		D62-22		D80-23		D100-13																			
21051		21191		21060/63		21070/73		21080/85		21090/86		21040		21041		21100																			
1:5	1:1	1:5	1:1	1:5	1:1	1:5	1:1	1:5	1:1	1:5	1:1	1:5	1:1	1:5	1:1	1:5	1:2																		
1600		1820		2500		3000		3600		4600		6200		8000		10000																			
55370-25585		65520-32760		78970-39975		94765-47970		113720-55450		145305-70850		218960-107050		266830-171085		333540-213860																			
36-52		35-52		37-52		37-52		37-53		37-53		35-50		36-45		36-45																			
686 (69950)		686 (69930)		1305 (132960)		1305 (132960)		1695 (172830)		1695 (172830)		1800 (183485)		2600 (265035)		2600 (265035)																			
1.0-6.0		1,1-6,6		1,6-7,5		2,0-9,0		2,5-12,0		3-16		4-30		6-60		7-100																			
20)*		20)*		22)*		22)*		38)*		38)*		38)*		30)**		30)**																			
5.0		7.5		8.0		10.0		11.5		16		20		25		30																			
0.5		0.5		1.0		1.0		1.5		1.5		2.0		2.6		2.6																			
32		32		67		67		89		89		98		155		155																			
9.0		9.0		19.0		19.0		17.0		17.0		31.5		32.0		32.0																			
1.2		1.2		1.7		1.7		1.5		1.5		1.5		1.0		1.0																			
3330	3475	3550	3695	5530	5810	6030	6310	7990	8400	8990	9400	12140	12550	16365	16905	20180	20720																		
100		100		180		180		400		400		400		750		750																			
---		---		---		---		---		---		---		---		---																			
---		---		---		---		---		---		---		---		---																			
---		---		---		---		---		---		---		---		---																			
11		11		20		20		20		20		72		135		135																			
15		15		23		23		25		25		34		220		220																			
75		75		100		100		100		100		125		125		125																			
4835		5685		4835		5685		5450		6260		5450		6260		5470		6285		5470		6285		5910		6910		6200		7200		6358		7358	
440		440		560		560		660		660		710		820		820																			
560		560		780		780		880		880		828		1110		1110																			
485		485		640		640		785		785		800		890		890																			
320		320		540		540		640		640		560		800		800																			
345		345		405		405		445		445		490		550		550																			
280		280		235		235		275		275		380		350		350																			
665		665		715		715		848		848		970		1110		1110																			
360 at Profile 2		360 at Profile 2		440 at Profile 3		440 at Profile 3		500 at Profile 4		500 at Profile 4		500 at Profile 5+7		660 at Profile 5+7		660 at Profile 5+7																			

5. Transport

5.1 Transport Safety



Warning

The Diesel pile hammer shall only be transported with an installed locking screw (piston) (3) and impact block clamp (5). If this is omitted, a shift in the center of gravity could cause sudden movements of the Diesel pile hammer! The piston and impact block may accidentally crash to the other end position! Crushing and impact danger!



Caution

The Diesel pile hammer and its accessories must be packaged, loaded and transported carefully to prevent damage! Check the Diesel pile hammer and all accessories regarding completeness and damages after delivery! Immediately notify the shipping agency or the appropriate dealer about problems!

The following transport safety devices must be installed prior to transporting the Diesel pile hammer:

- 1 Protective hood.** The protective hood prevents the entering of water, dust and foreign bodies. Attach the protective hood with the help of the two chains. Attach the hook located at the end of each chain to the respective eyelet.
- 2 Protective rail.** The protective rail prevents the entering of dirt, sand etc. in the combustion chamber. Attach the hook of the protective rail to the lifting slot of the upper section of the cylinder. Lock the protective rail with the clamp screw.
- 3 Piston locking bolts.** These piston safety bolts prevent the moving of the piston during transport. This prevents sudden shifts in the center gravity of the Diesel pile hammer. Omitting the installation of these bolts may cause sudden movements as well as damages, e.g., to the carrying! The piston safety bolts must be screwed fully! The piston must be in the lower end position! Two piston safety bolts must be used for type D80-23 through D100-13 (other types require only 1 piston safety bolt)!
- 4 Exhaust cover.** The exhaust covers (2 pieces 4 pieces for type D80 and above) prevent the entering of water, dust and foreign bodies. Screw the exhaust covers into the respective threads fitted at the exhaust.
- 5 Impact block clamp.** The impact block clamp prevents a moving of the impact block during transport. Without the impact block clamp the impact block may accidentally fall to the other end position! Install the impact block clamp as shown in the illustration!
- 6 Transport angles.** The transport angles allow a horizontal placing of the Diesel pile hammer. The Diesel pile hammer could be damaged during a horizontal placing, when the transport angles are not installed! Attach the transport angles into the provided threaded holes as shown in the illustration!

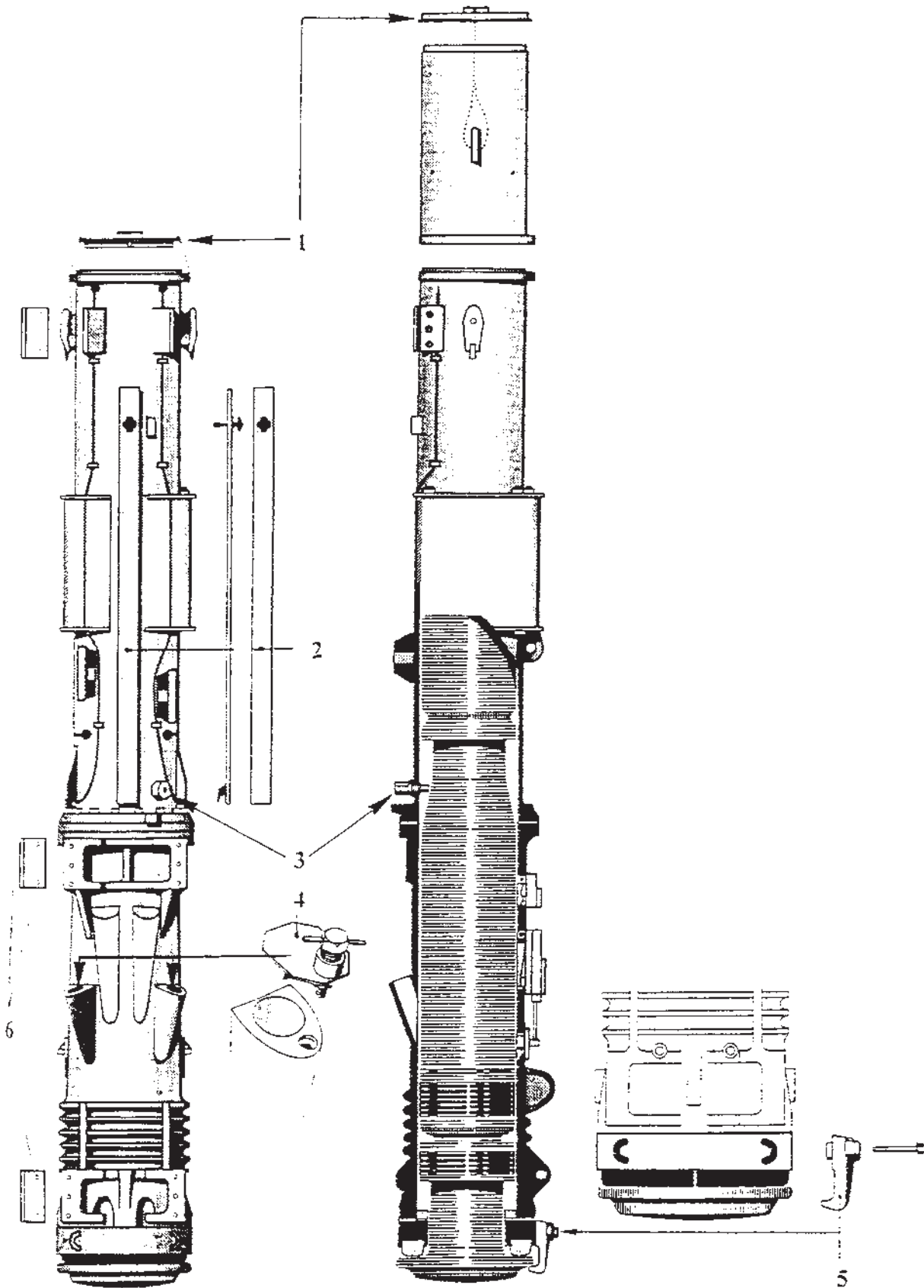

Transport cables

5.2 Transport cables



Danger

Prior to each use, the transport cables must be inspected visually in accordance with DIN 15020, Sheet 2! Use only approved cables to transport piles! Immediately remove and dispose of damaged cables (cable damage in accordance with DIN 15020, Sheet 2, Pages 5-4)! Use only steel cables that exhibit the proper load capacity and length (see table below)!

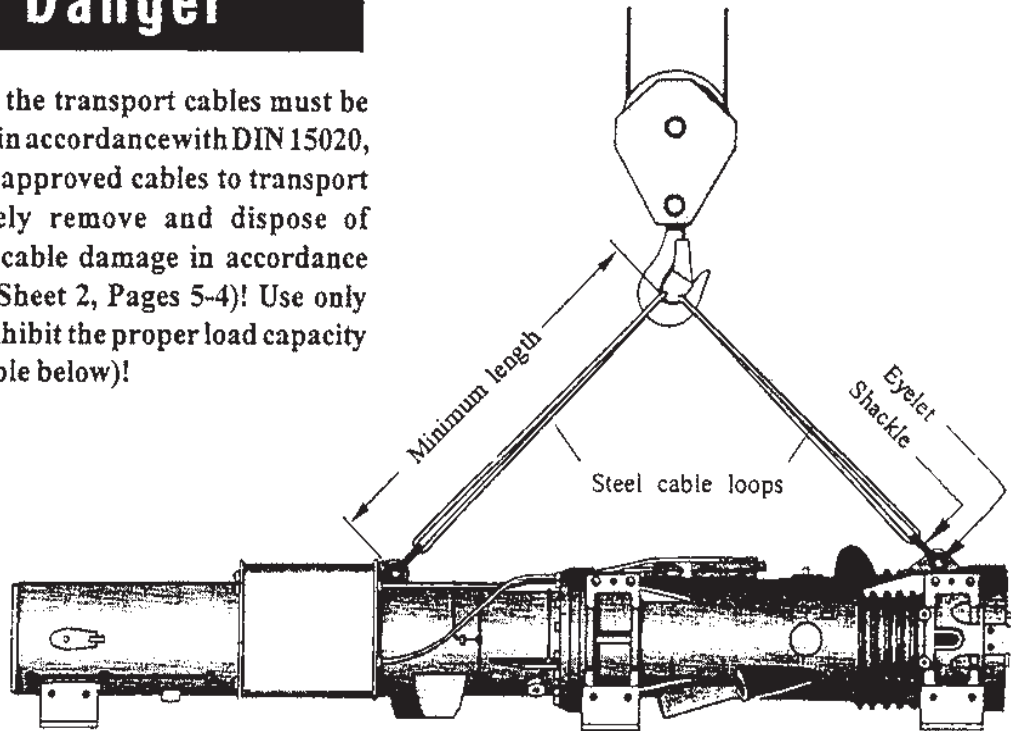

Type of Diesel pile hammer	Max. total weight (t)	2 steel cables in accordance with DIN 3066	Min. breaking strength of one cable at 1600 N/mm ² (2 steel cables = 4 x) (t)	Min. length (ft)	Eyelet diameter (in)	Shackle size (recommended)	Allowable shackle load DIN 8210 (t)
D5-43	1,7	ø0,512 in 11,48 ft	8,1	5,58	1,97	8	3
D6-32	1,9						
D8-22	2,2						
D12-32	3,0						
D16-32	3,8						
D19-42	4,0	ø0,709 in 21,3 ft	15,6	6,23	1,97	10	10
D25-32/33	6,9						
D30-32/33	7,5						
D36-32/33	9,8						
D46-32/33	10,8	ø0,709 in 21,3 ft	15,6	6,56	1,97	10	10
D62-22	14,1						
D80-23	20,1						
D100-13	23,9	ø1,261 in 18,0 ft	53,2	8,86	2,44	16	16

Possible cable damage

Possible Cable damage

Corkscrew-like formation



Replace the steel cable when X (see illustration) is larger than or equal to 1/3 of the cable diameter at the worst damage location!

Basket formation



Steel cable must be replaced even when it exhibits only small basket formation!

Loop formation



Replace the cable when the loop formation of individual wires causes a substantial change in the cable structure.

Loosening of individual wires



Replace the cable, when loose wires were caused by just or wear. When the loosening effect is caused in another manner, a decision regarding the replacing of the cable must be made on the basis of the wire breaks that are sure to follow.

Knots



Replace the steel cable, when many knots have formed!

Constrictions



Replace steel cables exhibiting strong constrictions!

Flattening



Flat spots lead to an increase in wire breaks. Replace the steel cable, when there are broken wires or strong flattening effects!

Breakouts



Replace steel cables with one or more breakouts!

Kinks



Replace steel cables exhibiting one or more kinks!

Lifting with the lifting equipment

5.3 Lifting with lifting equipment



Never walk under suspended loads! Danger to life!

Use only lifting equipment that is in an excellent technical condition, exhibits a great stability and is designed to lift the applicable loads! Use only approved and suitable steel cables and shackles (See Chapter 5.2 "Transport cables")! Danger to life!



You must wear a hard hat, safety gloves, safety boots and suitable work clothes! Danger of injuries!

The Diesel pile hammer shall be lifted only with installed safety devices (See Chapter 5.1 "Transport safety")! Danger of injuries and property damage!

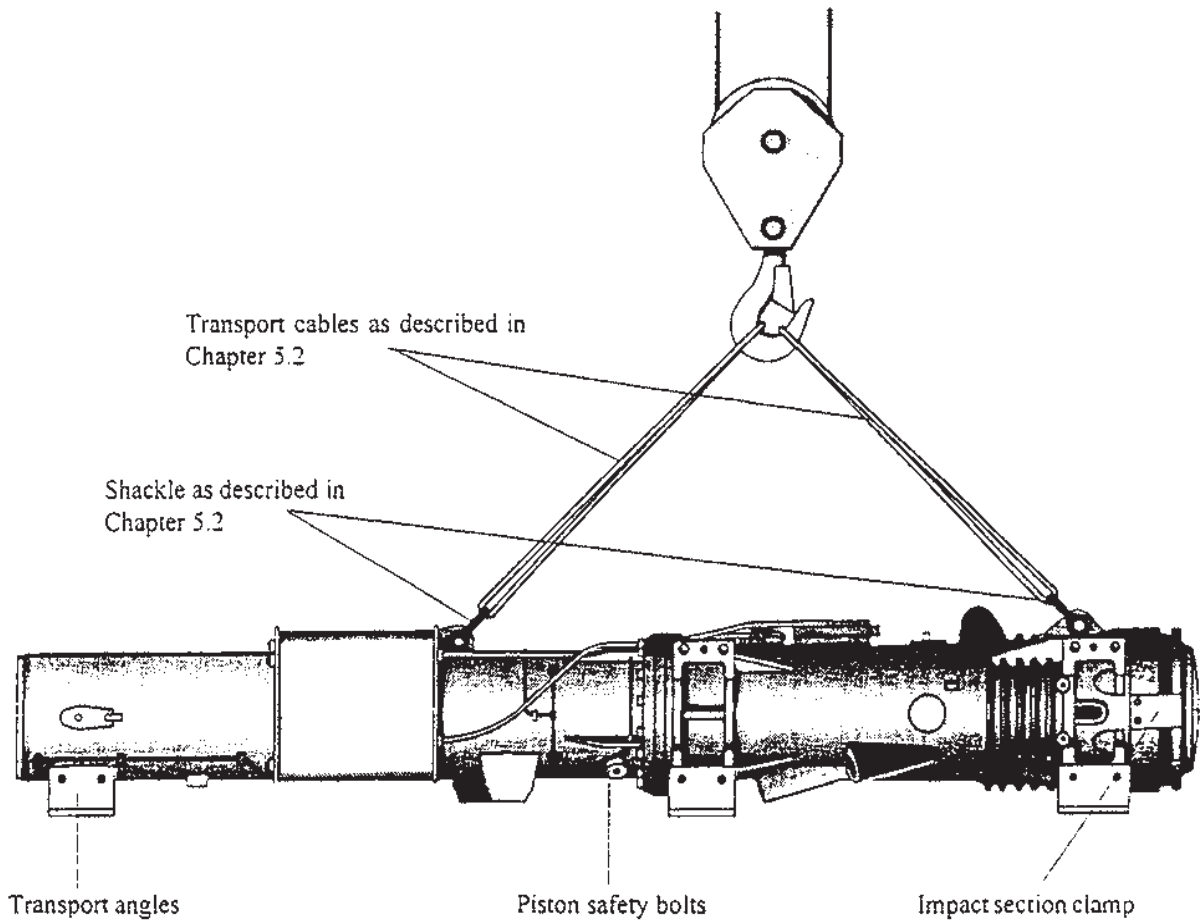

Assembly and mode of operation

6. Assembly and mode of operation

6.1 Components of Diesel pile hammers D5-43 through D6-32

- 2 Upper cylinder
- 3 Lifting ears
- 4 Fuel tank with integral lubricant and ether tank
- 5 Lifting padeyes
- 6 Lifting dogs
- 7 Lubrication lines
- 8 Locking screw (piston)
- 9 Trip cam lever engaging point
- 10 Lubrication pump
- 11 Fuel/ventilation line
- 12 Fuel control pump
- 13 Injection valve
- 14 Pump guard
- 15 Lower cylinder
- 16 Blow out plug
- 17 Outer cylinder end ring (two sections)
- 18 Rubber ring (two sections)
- 19 Impact block
- 20 Key plate bolts
- 21 Trip cam lever release point
- 22 Hammer guides
- 23 ports

- A Tripping device
- A1 Guide gibs
- A2 Lever to activate driving pin
- A3 Pawl
- A4 Trip cam lever
- A5 Latch lever

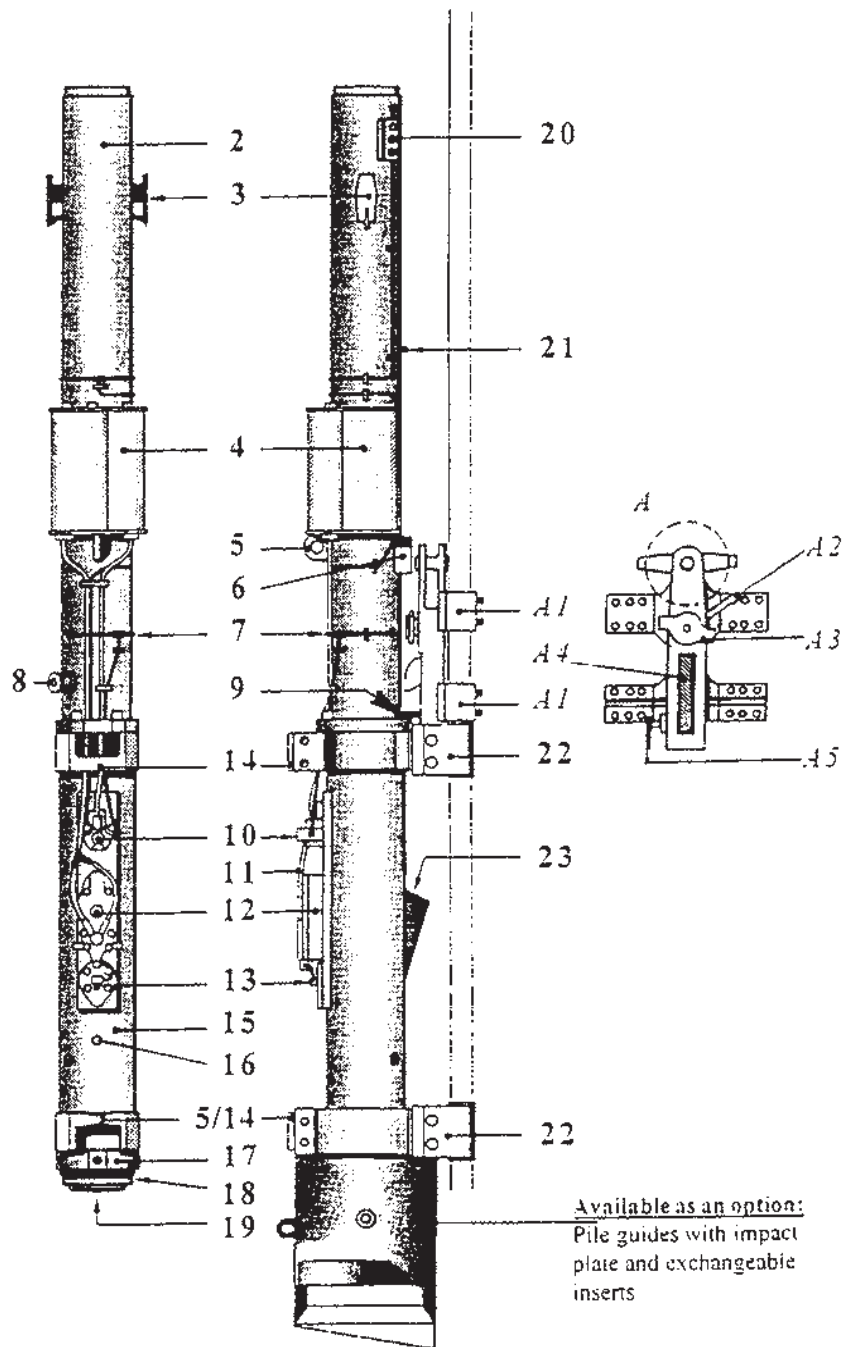

Components of diesel pile hammer D8-22

6.2 Components of Diesel pile hammer D 8-22

- 2 Upper cylinder
 - 3 Liftingears
 - 4 Fuel tank with integral lubricant and ether tank
 - 5 Lifting padeyes
 - 6 Lifting dogs
 - 7 Lubrication lines
 - 8 Locking screw (piston)
 - 9 Trip cam lever engaging point
 - 10 Lubrication
 - 11 Fuel/ventilationline
 - 12 Fuel control pump
 - 13 Injection valve
 - 14 Pump guard
 - 15 Lower cylinder
 - 16 Blow out plug
 - 17 Outer cylinder end ring (two sections)
 - 18 Rubber ring (two sections)
 - 19 Impact block
 - 20 Key plate bolts
 - 21 Trip cam lever release point
 - 22 Hammer guides
 - 23 Exhaust ports
-
- A Tripping device
 - A1 Guide gibs
 - A2 Lever to activate driving pin
 - A3 Driving pin
 - A4 Powl
 - A5 Trip cam lever

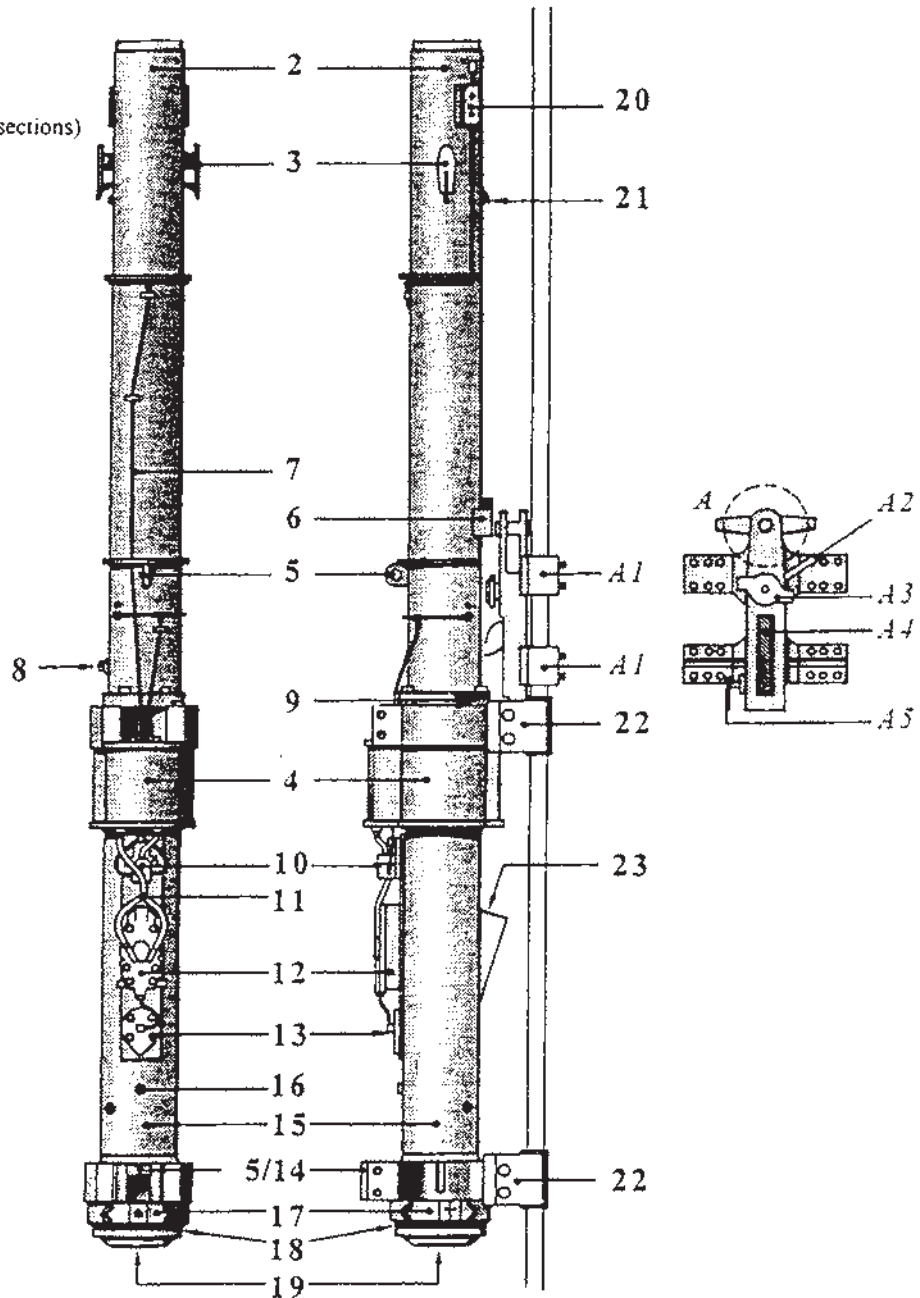

Components of diesel pile hammer D12-32

6.3 Components of Diesel pile hammers D12-32

- 2 Upper cylinder
 - 3 Lifting ears
 - 4 Fuel tank with integral lubricant and ether tank
 - 5 Lifting padeyes
 - 6 Lifting dogs
 - 7 Lubrication lines
 - 8 Locking screw (piston)
 - 9 Trip cam lever engaging point
 - 10 Lubrication pump
 - 11 Fuel ventilation line
 - 12 Fuel control pump
 - 13 Injection valve
 - 14 Pump guard
 - 15 Lower cylinder
 - 16 Blow out plug
 - 17 Outer cylinder end ring (two sections)
 - 18 Rubber ring (two sections)
 - 19 Impact block
 - 20 Key plate bolts
 - 21 Trip cam lever release point
 - 22 Hammer guides
 - 23 Exhaust ports
-
- A Tripping device
 - A1 Guide gibs
 - A2 Lever to activate driving pin
 - A3 Driving pin
 - A4 Pawl
 - A5 Trip cam lever

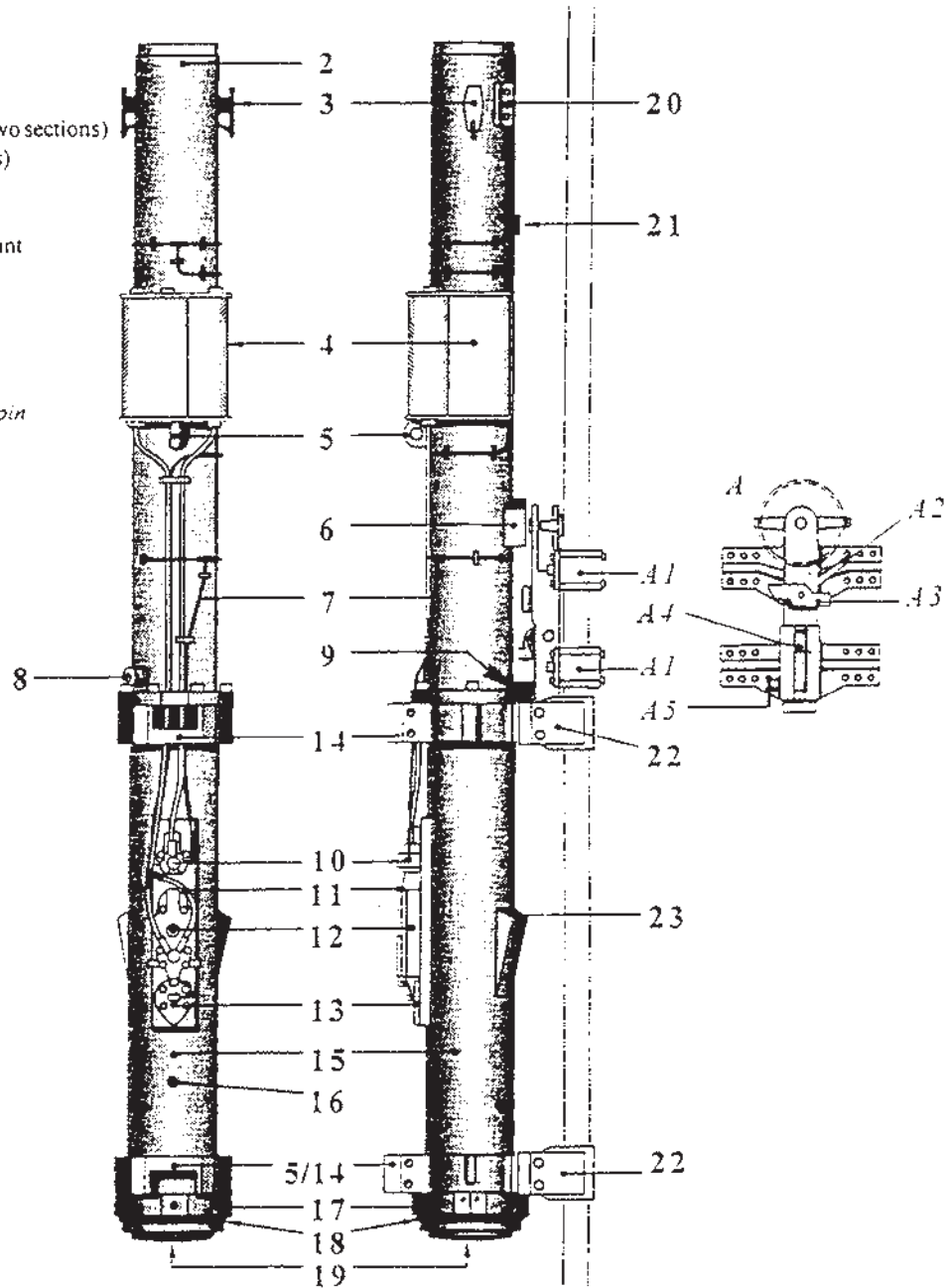

Components of diesel pile hammer D16-32 and D19-42

6.4 Components of Diesel pile hammer D16-32 and D19-42

- 1 Upper cylinder extension
- 2 Upper cylinder
- 3 Lifting ears
- 4 Fuel tank with integral lubricant and ether tank
- 5 Lifting padeyes
- 6 Lifting dogs
- 7 Lubrication lines
- 8 Locking screw (piston)
- 9 Trip cam lever engaging point
- 10 Lubrication pump
- 11 Fuel / ventilation line
- 12 Fuel control pump
- 13 Injection valve
- 14 Pump guard
- 15 Lower cylinder
- 16 Blow out plug
- 17 Outer cylinder end ring (two sections)
- 18 Rubber ring (two sections)
- 19 Impact block
- 20 Key plate bolts
- 21 Trip cam lever release point
- 22 Hammer guides
- 23 Exhaust ports
- 24 Flange with catch ring groove

- A Tripping device
- A1 Guide gibs
- A2 Lever to activate driving pin
- A3 Driving pin
- A4 Pawl
- A5 Trip cam lever

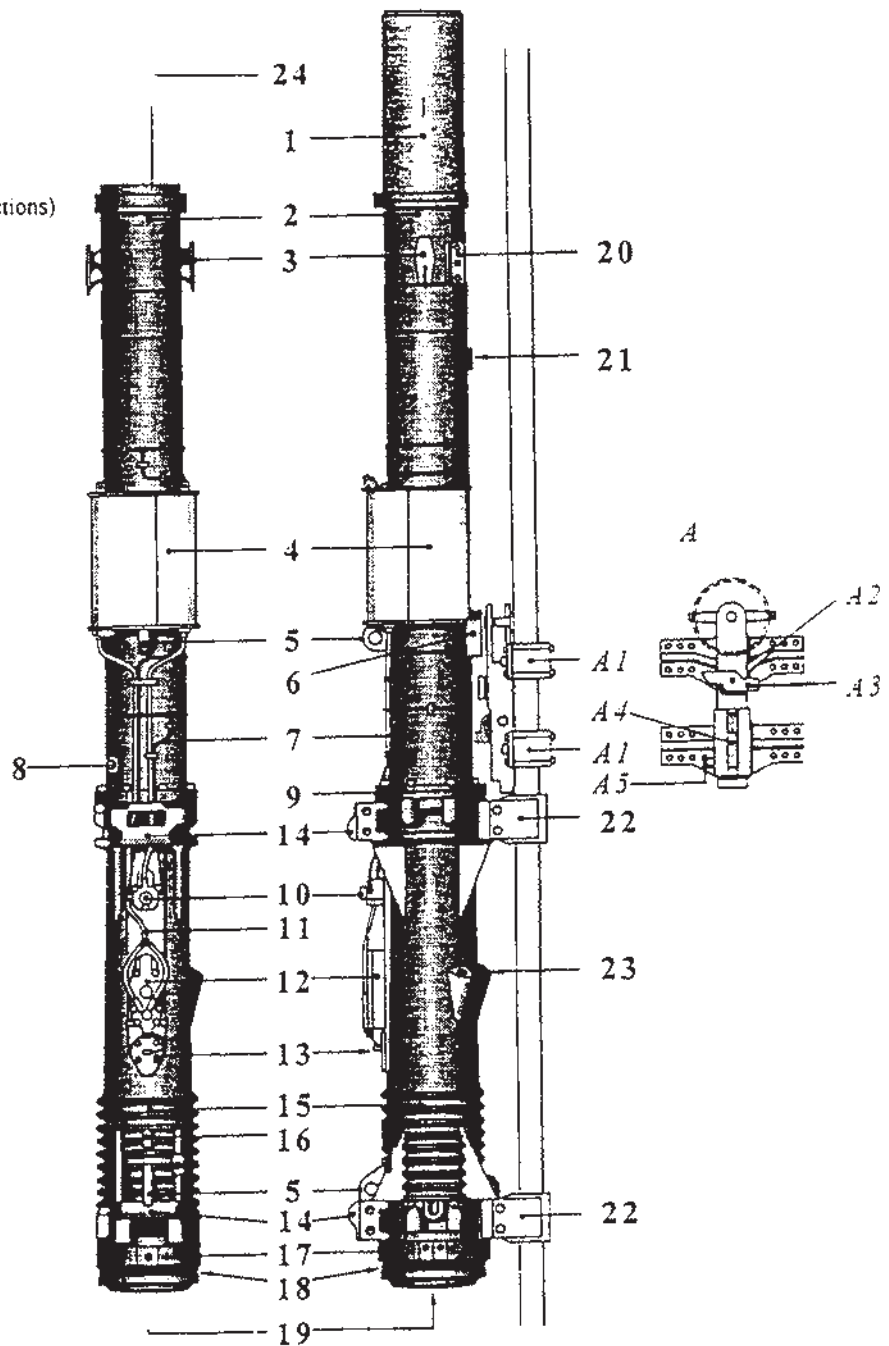

Components of diesel pile hammer D25-32/33 and D30-32/33

6.5 Components of Diesel pile hammer D 25-32/33 and D 30-32/33

- 1 Upper cylinder extension
- 2 Upper cylinder
- 3 Lifting ears
- 4 Fuel tank with integral lubricant and ether tank
- 5 Lifting padeyes
- 6 Lifting dogs
- 7 Lubrication lines
- 8 Locking screw (piston)
- 9 Trip cam lever engaging point
- 10 Lubrication pump
- 11 Fuel ventilation line
- 12 Fuel control pump
- 13 Injection valve
- 14 Pump guard
- 15 Lower cylinder
- 16 Blow out plug
- 17 Outer cylinder end ring (two sections)
- 18 Rubber ring (two sections)
- 19 Impact block
- 20 Key plate bolts
- 21 Trip cam lever release point
- 22 Hammer guides
- 23 Exhaust ports
- 24 Flange with catch ring groove

- A Tripping device
- A1 Guide gibs
- A2 Lever to activate driving pin
- A3 Driving pin
- A4 Pin
- A5 Trip cam lever

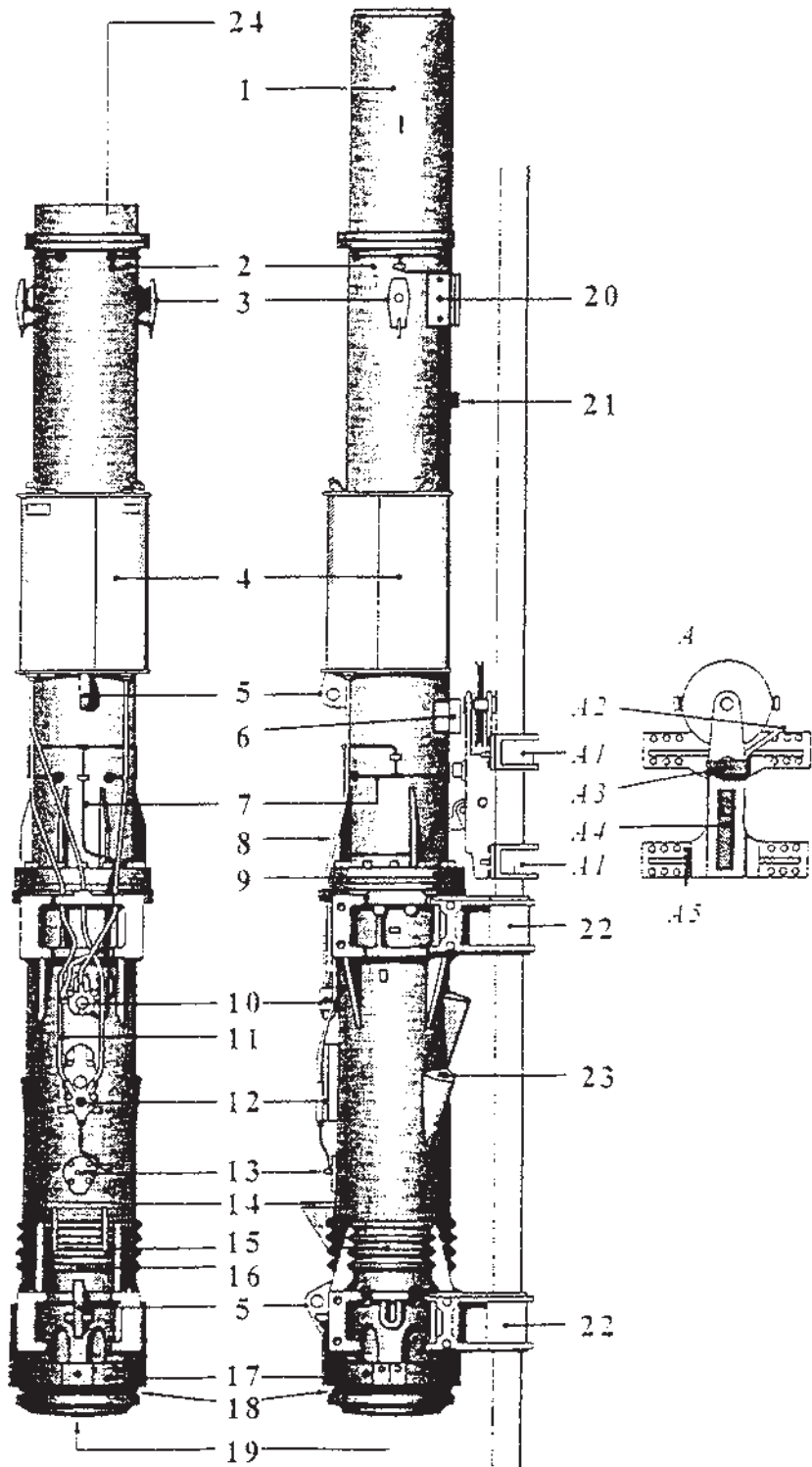

Components of diesel pile hammer D36-32/33 and D46-32/33

6.6 Components of Diesel pile hammer D36-32/33 and D46-32/33

- 1 Upper cylinder extension
- 2 Upper cylinder
- 3 Lifting ears
- 4 Fuel tank with integral lubricant and ether tank
- 5 Lifting padeyes
- 6 Lifting dogs
- 7 Lubrication lines
- 8 Locking screw (piston)
- 9 Trip cam lever engaging point
- 10 Lubrication pump
- 11 Fuel/ventilation line
- 12 Fuel control pump
- 13 Injection valve
- 14 Pump guard
- 15 Lower cylinder
- 16 Blow out plug
- 17 Outer cylinder end ring (two sections)
- 18 Rubber ring (two sections)
- 19 Impact block
- 20 Key plate bolts
- 21 Trip cam lever release point
- 22 Hammer guides
- 23 Exhaust ports
- 24 Flange with catch ring groove

- A Tripping device
- A1 Guide gibs
- A2 Lever to activate driving pin
- A3 Driving pin
- A4 Pawl
- A5 Trip cam lever

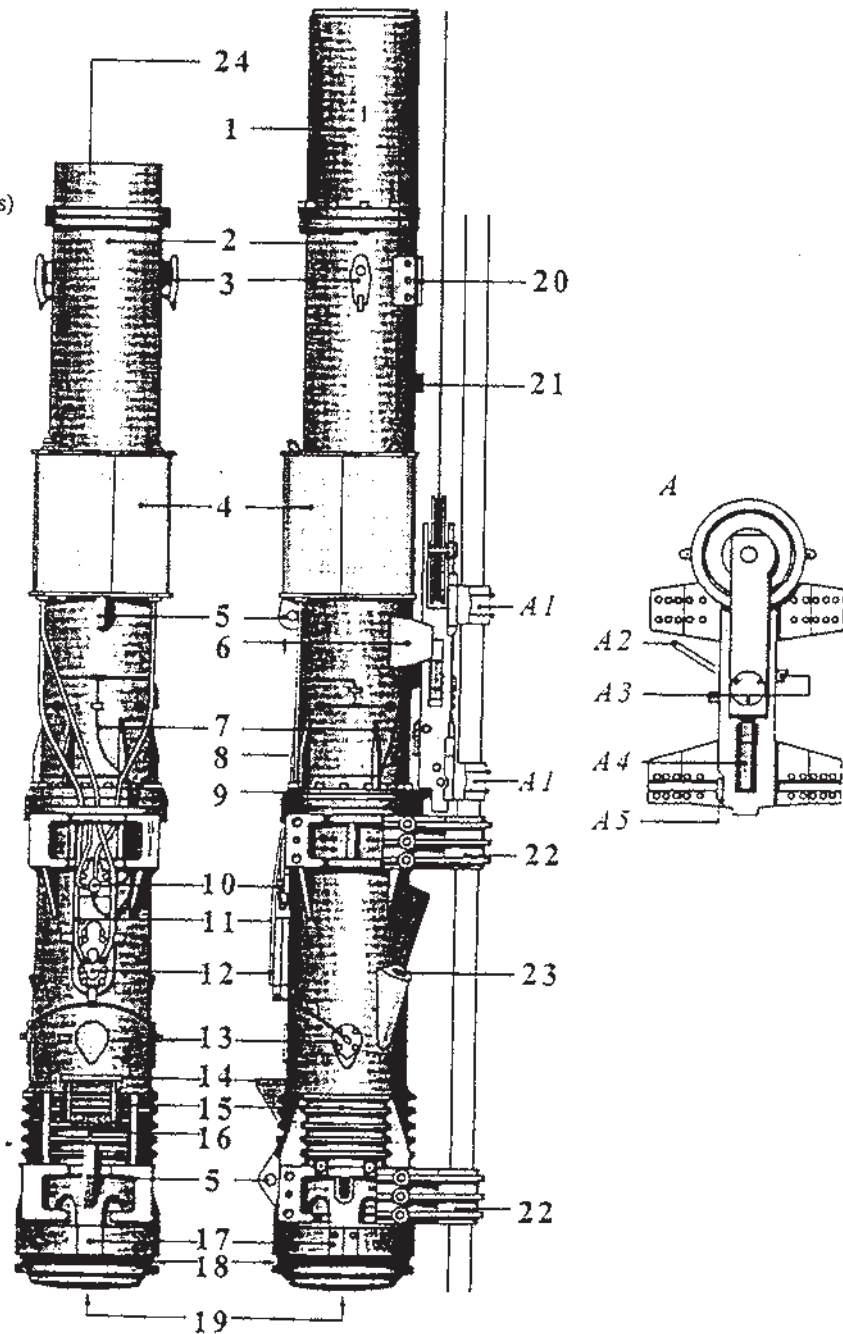

Components of diesel pile hammer D62-22

6.7 Components of Diesel pile hammer D62-22

- 1 Upper cylinder extension
 - 2 Upper cylinder
 - 3 Lifting ears
 - 4 Fuel tank with integral lubricant and ether tank
 - 5 Lifting padeyes
 - 6 Lifting dogs
 - 7 Lubrication lines
 - 8 Locking screw (piston)
 - 9 Trip cam lever engaging point
 - 10 Lubrication pump
 - 11 Fuel ventilation line
 - 12 Fuel control pump
 - 13 Injection valve
 - 14 Pump guard
 - 15 Lower cylinder
 - 16 Blow out plug
 - 17 Outer cylinder end ring (two sections)
 - 18 Rubber ring (two sections)
 - 19 Impact block
 - 20 Key plate bolts
 - 21 Trip cam lever release point
 - 22 Hammer guides
 - 23 Exhaust ports
 - 24 Flange with catch ring groove
- A Tripping device
 - B Guide gibs
 - C Lever to activate driving pin
 - D Driving pin
 - E Pawl
 - F Trip cam lever

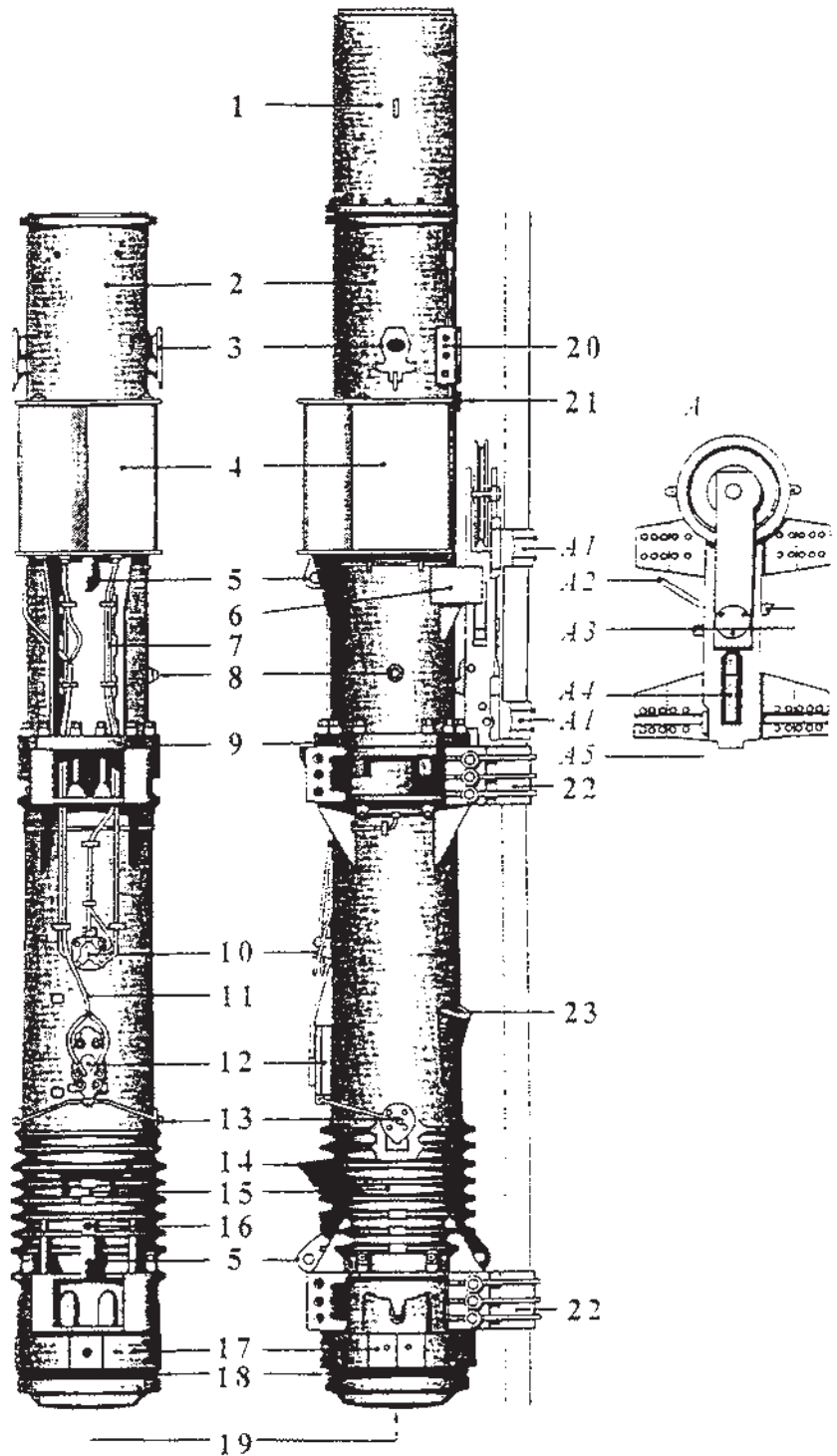

Components of diesel pile hammer D80-23 and D100-13

6.8 Components of Diesel pile hammer D80-23 and D100-13

- 1 Upper cylinder extension
 - 2 Upper cylinder
 - 3 Lifting ears
 - 4 Fuel tank with integral lubricant and ether tank
 - 5 Lifting padeyes
 - 6 Lifting dogs
 - 7 Lubrication lines
 - 8 Locking screw (piston)
 - 9 Trip cam lever engaging point
 - 10 Lubrication pump
 - 11 Fuel/ventilation line
 - 12 Fuel control pump
 - 13 Injection valve
 - 14 Pump guard
 - 15 Lower cylinder
 - 16 Blow out plug
 - 17 Outer cylinder end ring (two sections)
 - 18 Rubber ring (two sections)
 - 19 Impact block
 - 20 Key plate bolts
 - 21 Trip cam lever release point
 - 22 Hammer guides
 - 23 Exhaust ports
 - 24 Flange with catch ring groove
- A Tripping device
 - A1 Guide gibs
 - A2 Lever to activate driving pin
 - A3 Driving pin
 - A4 Pawl
 - A5 Trip cam lever

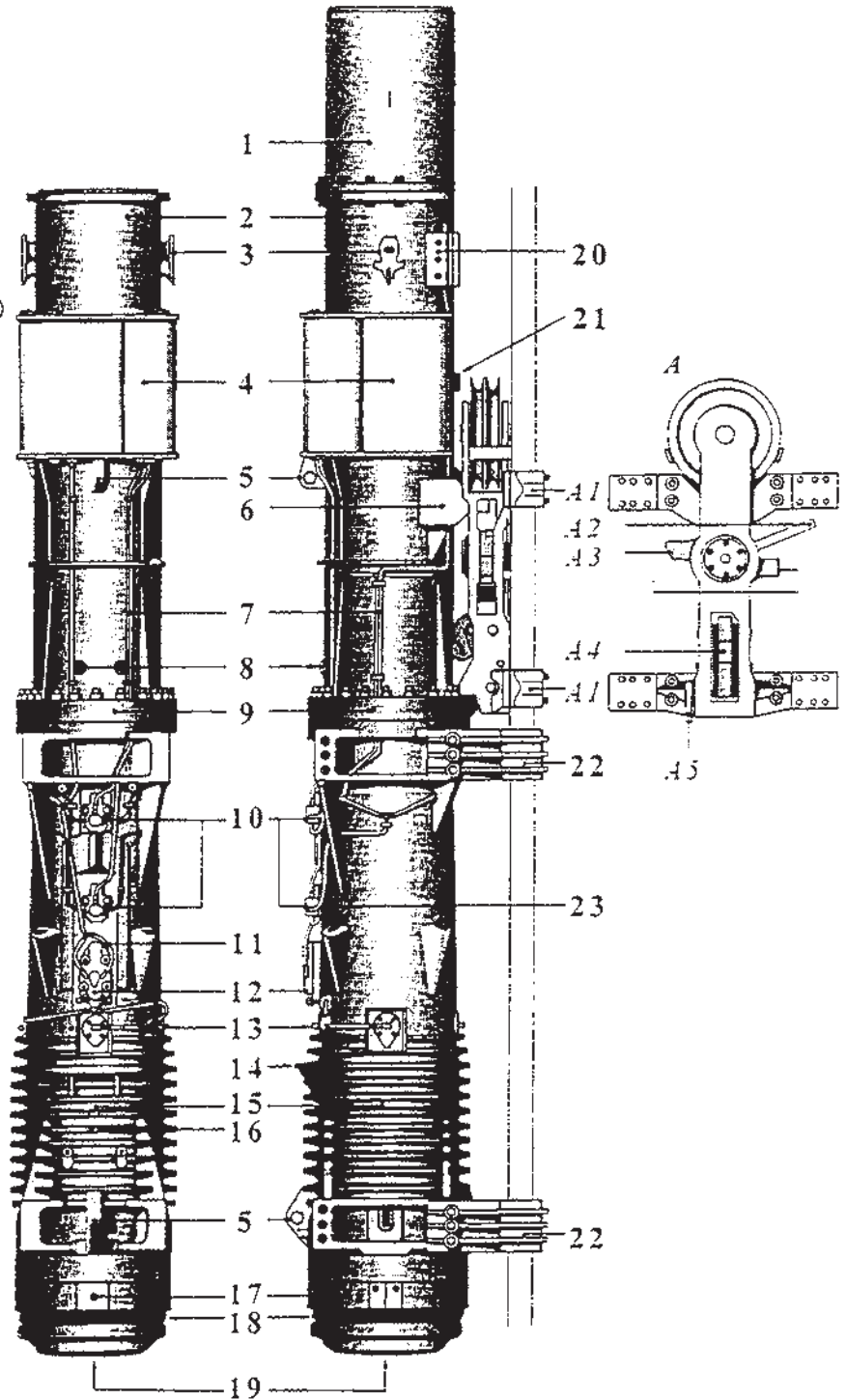

Longitudinal section

6.9 Longitudinal section

- 2 Upper cylinder
- 10 Lubrication pump
- 12 Fuel control pump
- 18 Rubber ring (two sections)
- 19 Impact block
- 23 Exhaust ports
- 24 Flange with catch ring groove
- 26 Piston
- 27 Piston catch ring
- 28 Cylinder sleeves
- 29 Inner damp ring

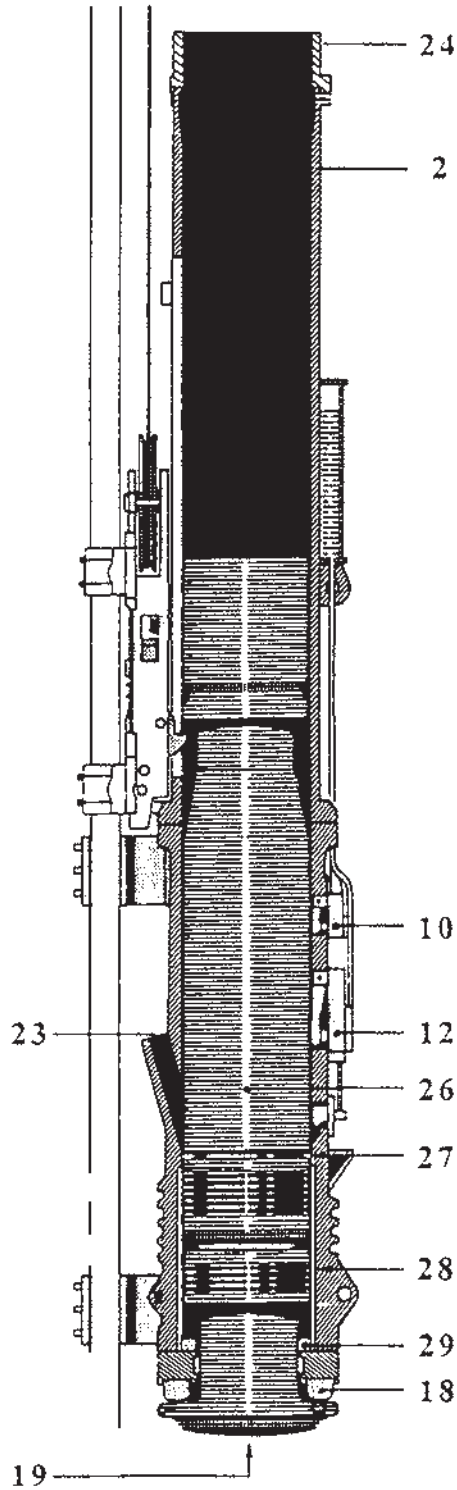

Operating mode of the diesel pile hammer

6.10 Operating mode of the Diesel pile hammer

Diesel pile hammers are used to drive pile into a supporting soil layer. The mode of operation is similar to that of a hammer used to drive a nail.

The piston activates the pump lever during its fall. The Diesel fuel is in that manner sprayed onto the surface of the impact block (1). The air in the cylinder is compressed as soon as the piston runs past the exhaust openings. The strongly increasing compression pressure drives the piston and the impact head below it on the material to be driven.

The following occurs when the hammer impacts (2):

- The pile is driven into the soil
- The Diesel fuel is atomized.

The atomized Diesel fuel ignites, because the enormous compression causes a substantial increase in the air temperature of the cylinder volume (working principle of the Diesel engine). There is an explosion. The explosion causes the following:

- It drives the pile further into the soil.
- The piston is driven upward (stroke).

The exhaust openings become exposed with the upward driving of the piston. The pressure in the cylinder volume causes the exhaust gases to be pushed through the exhaust (3). This reduces the pressure in the cylinder to zero.

The piston continues to move upward. This causes a suction effect (vacuum) in the cylinder volume. Said vacuum ensures that fresh air is suctioned in to purge the cylinder volume (4).

The pump lever is released during the further upward movement of the piston. The pump lever returns to its original position. Diesel fuel is again supplied to the fuel control pump.

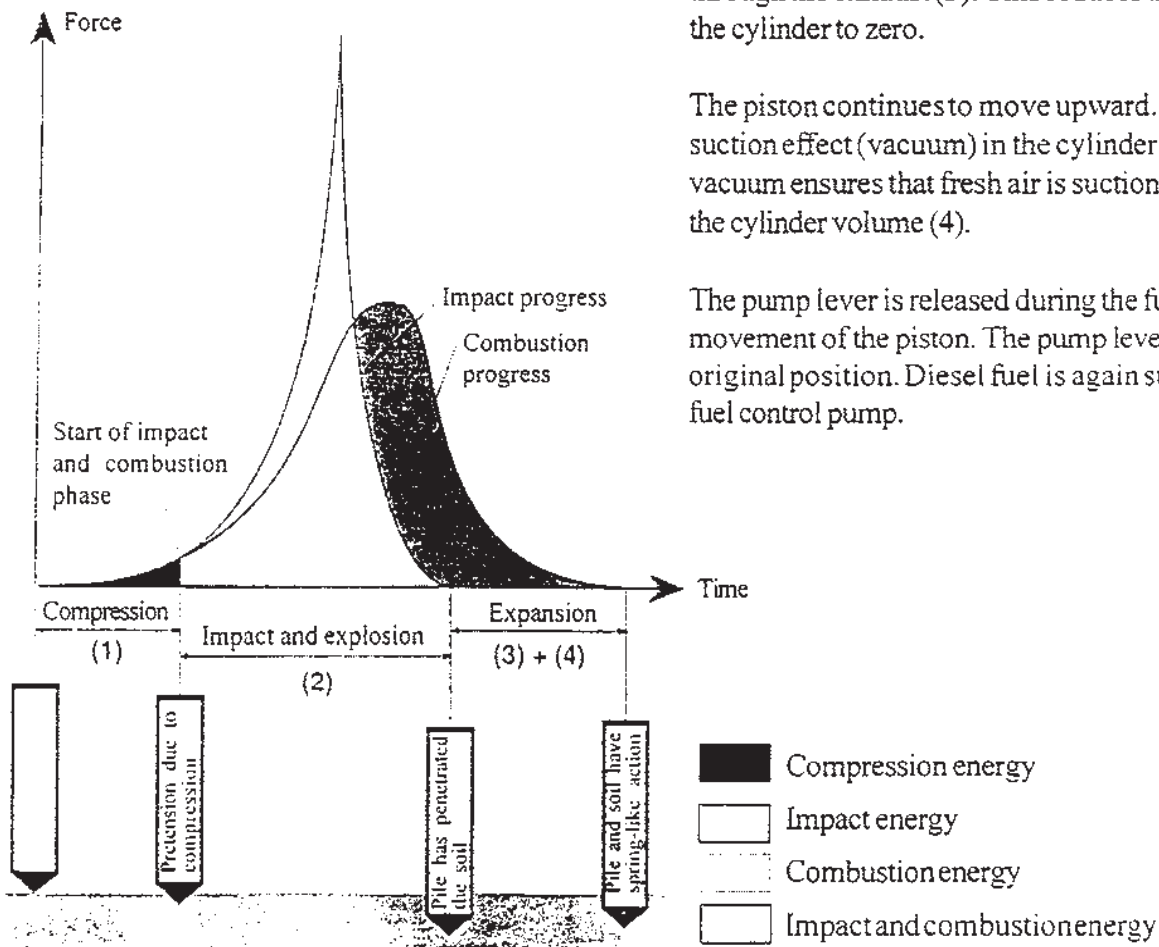

Operating mode of the diesel pile hammer

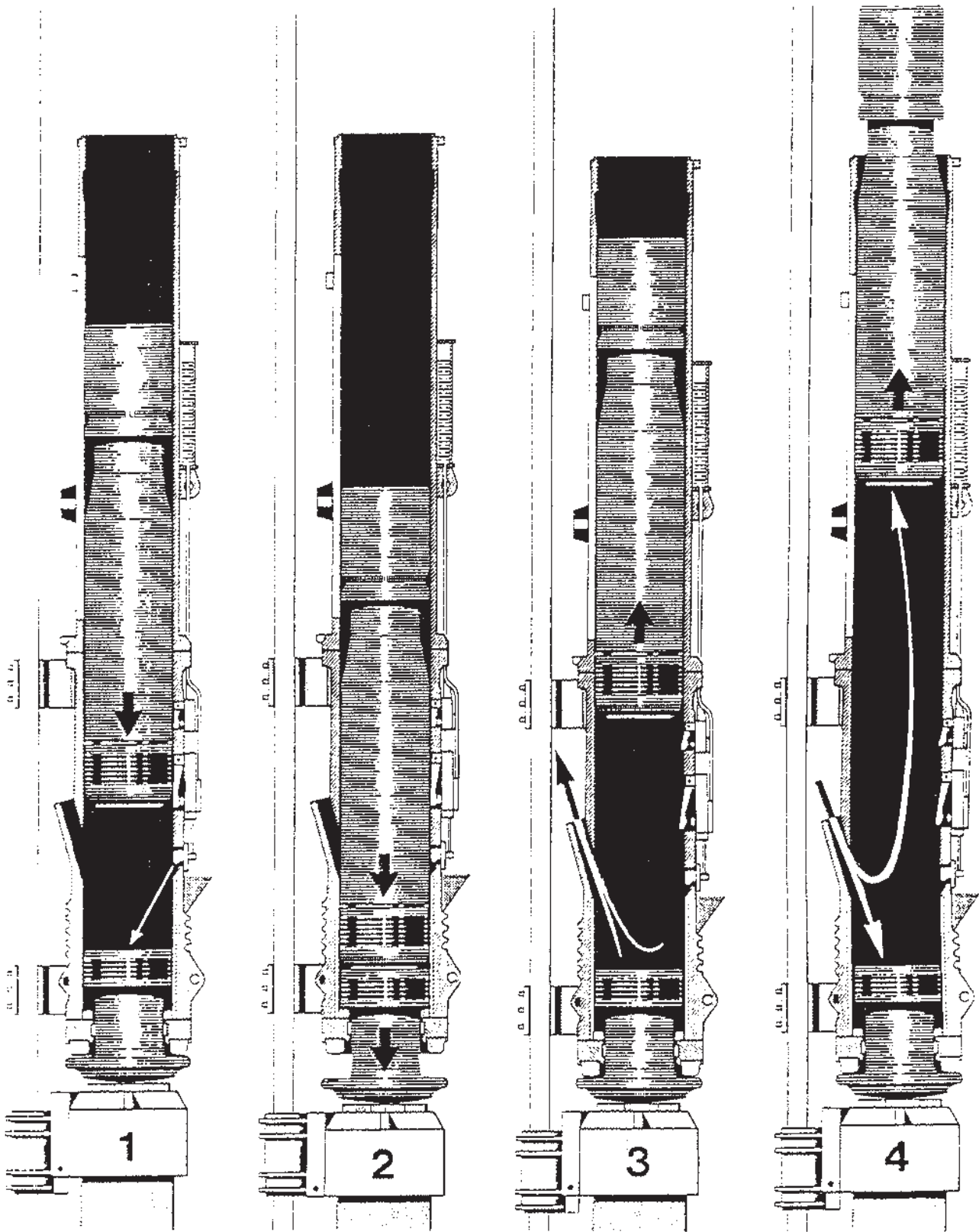

7. Assembly and conversion

7.1 Guiding possibilities

The following indicates and describes different possibilities to guide the Diesel pile hammer with a lead. You must consult with DELMAG should you decide on a different guiding system for the Diesel pile hammer.



Danger

Follow the operating instructions for the lead! Use only leads with a sufficiently high capacity and stability! Danger to life!

Guiding in front of the lead

The Diesel pile hammer is attached to the front of the lead using the guide brackets.

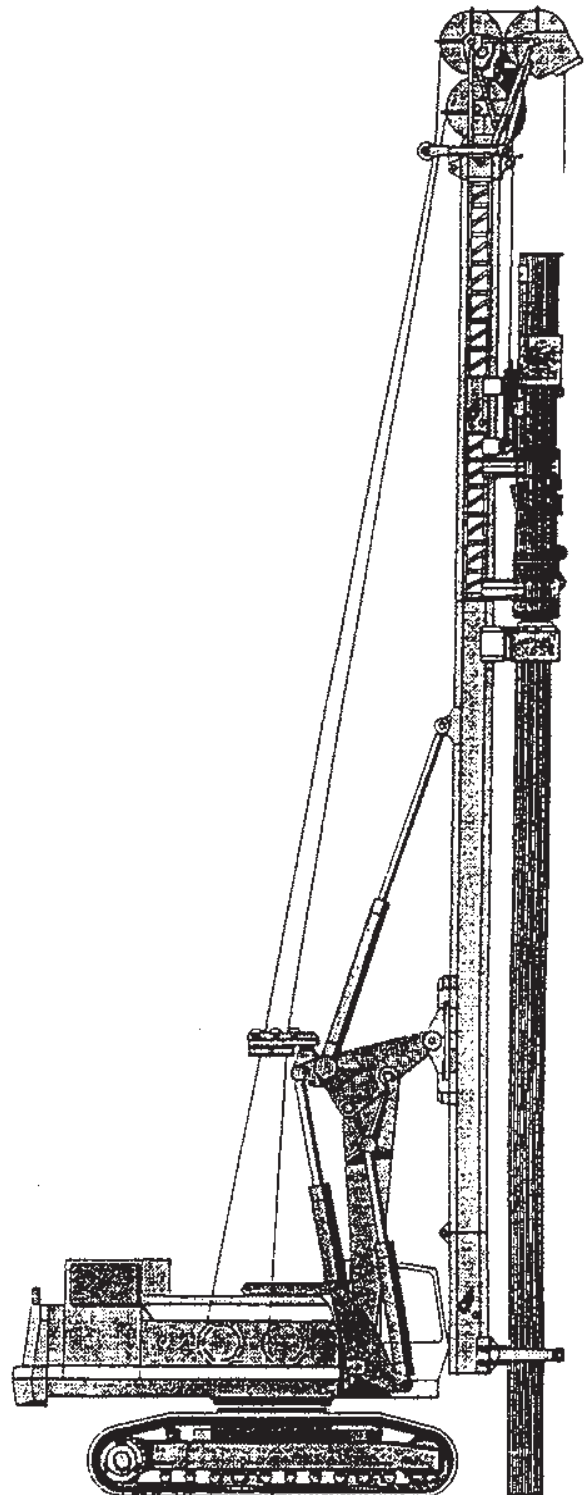

Example: drilling and pile-driving equipment RH 1433 used with a hydraulic excavator Liebherr HS 841 HD Special.

Guiding inside cable-suspended lead

Guiding in the rope suspended /caisson type lead

In this variant, the Diesel pile hammer is attached in the lead using the guiding brackets. The lead encloses the Diesel pile hammer.

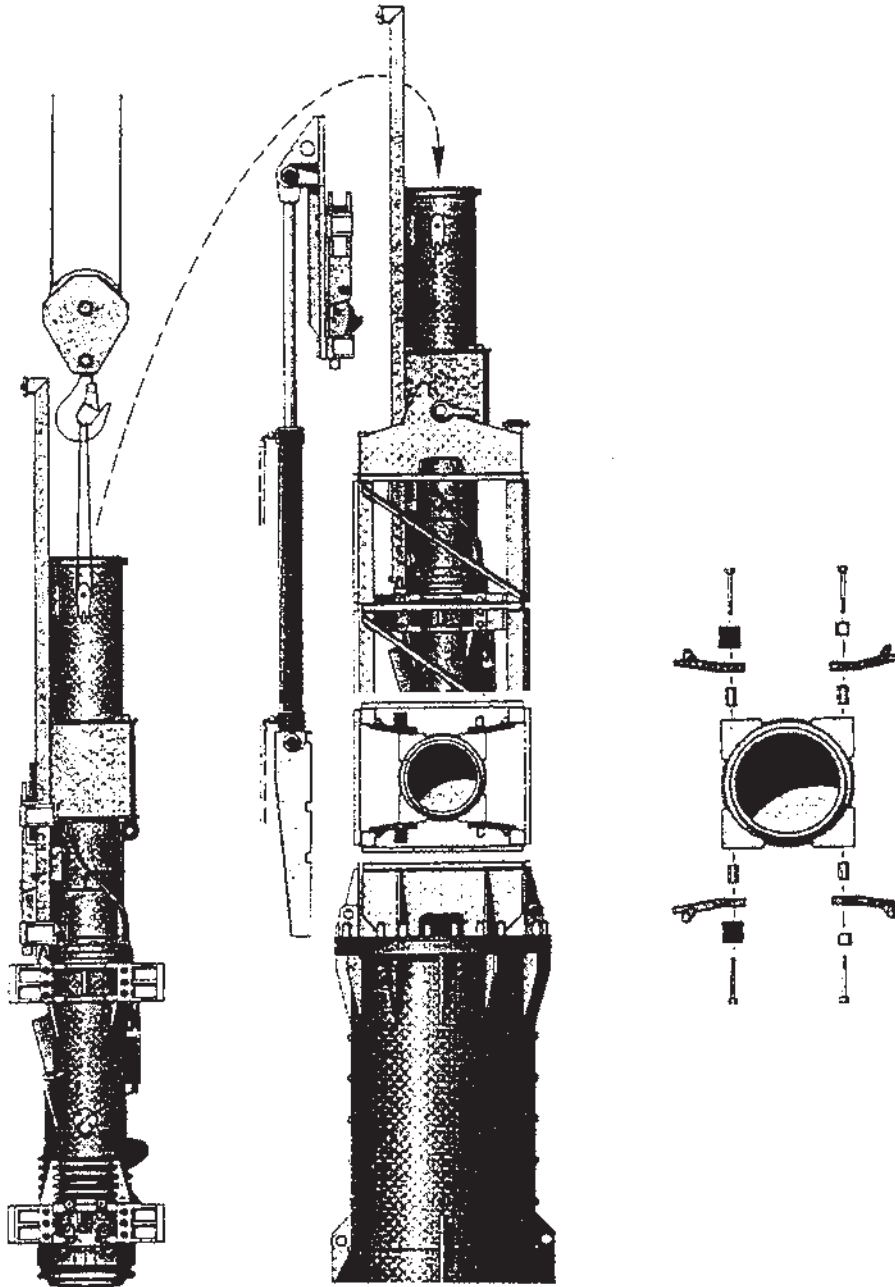

Example: rope suspended lead Typ MAR (for piles and pipes). Tripping device on the Diesel pile hammer, activated by cable or hydraulic.

Guiding in the rope suspended lead

Guiding in the rope suspended lead

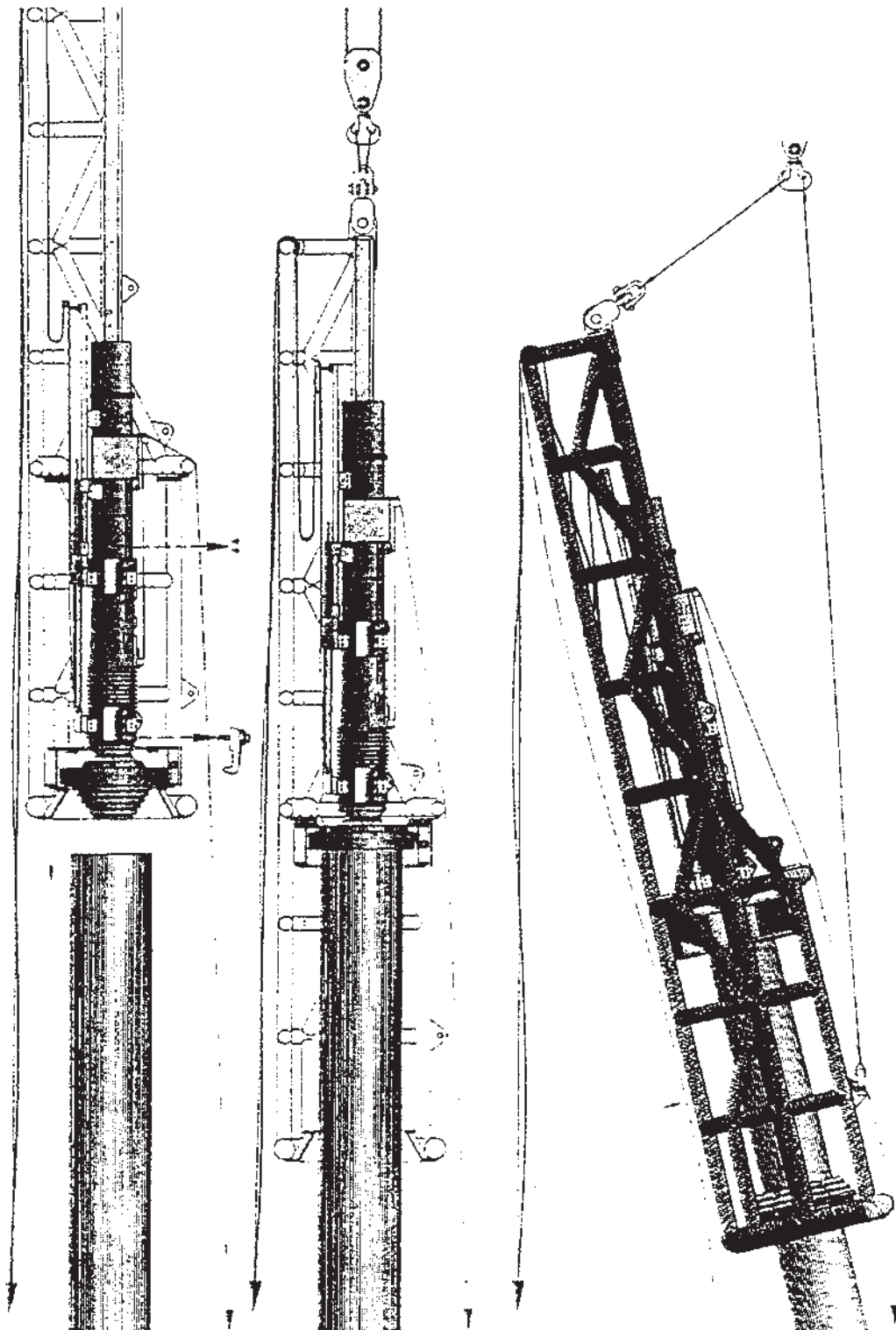

Example: rope suspended lead Typ MAR 8017, designed for D80/100, with hydraulic starter unit on the Diesel pile hammer.

Guiding in the U-type lead

Guiding in the U-type lead

The Diesel pile hammer is attached in the lead using the guide brackets. The U-type lead encloses the Diesel pile hammer on three sides.



The tripping device must be continuously adjusted to match the pile-driving progress!

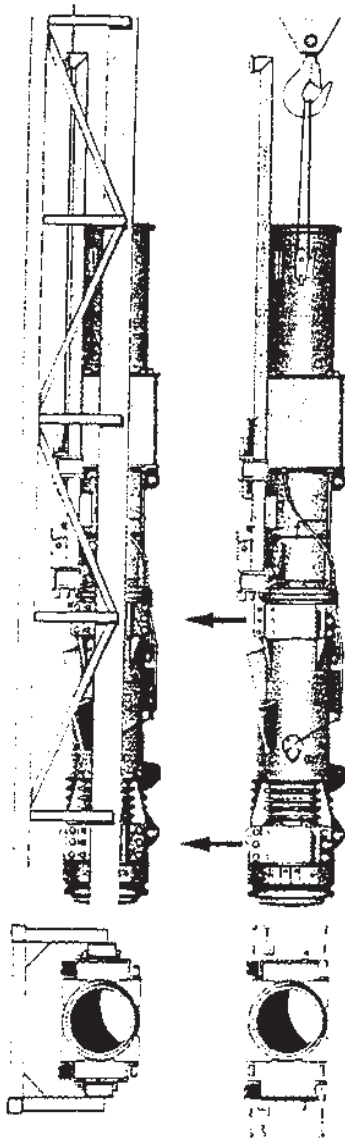

Example: U-type lead; tripping device at the Diesel pile hammer

Guiding in the Dutch-type lead

The Diesel pile hammer is attached between the two columns of the lead using the guide brackets. The lead guides the Diesel pile hammer on both sides.



The tripping device must be continuously adjusted to match the pile-driving progress!

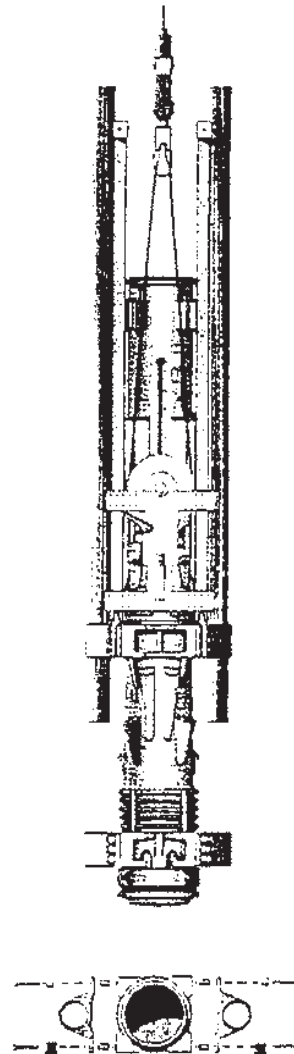

Example: Dutch-type lead; tripping device at the Diesel pile hammer

Conversion for the driving of batter piles

7.2 Conversion for the driving of batter piles

The use of the extension of the upper cylinder section for the driving of batter piles is a function of the batter. Calculate the required batter prior to putting the equipment into operation! Check the following points with the help of these two diagrams:

- Is the available Diesel pile hammer suited for the required batter?
- Is it necessary to extend the upper cylinder section?
- Is the blow energy still at a sufficient level?

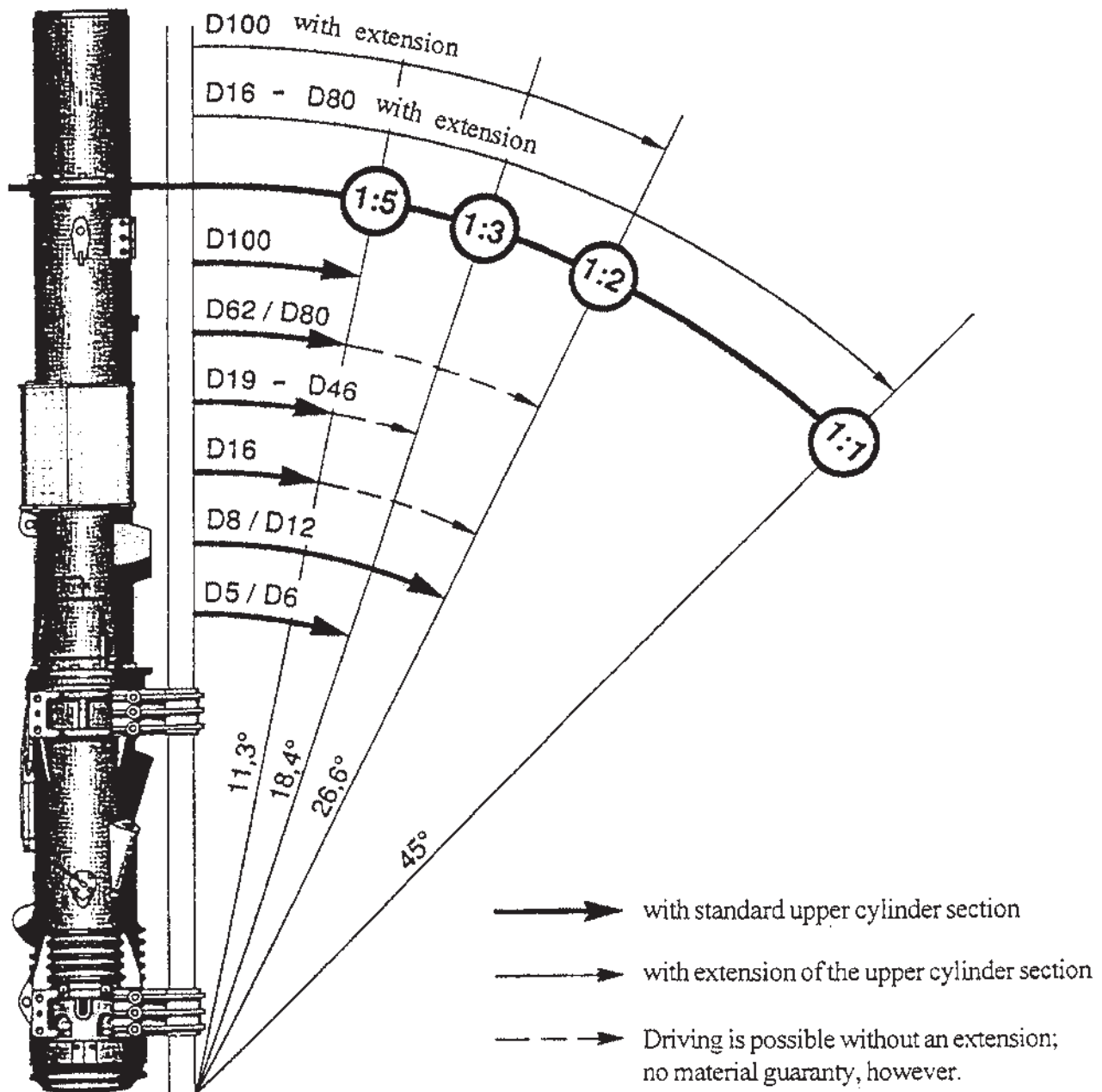

Blow energy for the driving of batter piles

Blow energy for the driving of batter piles

The increased friction of the piston and of the impact block causes a decrease in the blow energy when driving batter piles. The wear on the cylinder and guiding components, for example, is also increased. The remaining blow energy can be calculated with the formula shown below:

$$\text{Remaining blow energy (in \% of the max. blow energy)} = \frac{\cos \alpha - 0,1 \sin \alpha}{\cos \alpha + 0,1 \sin \alpha} \times 100$$

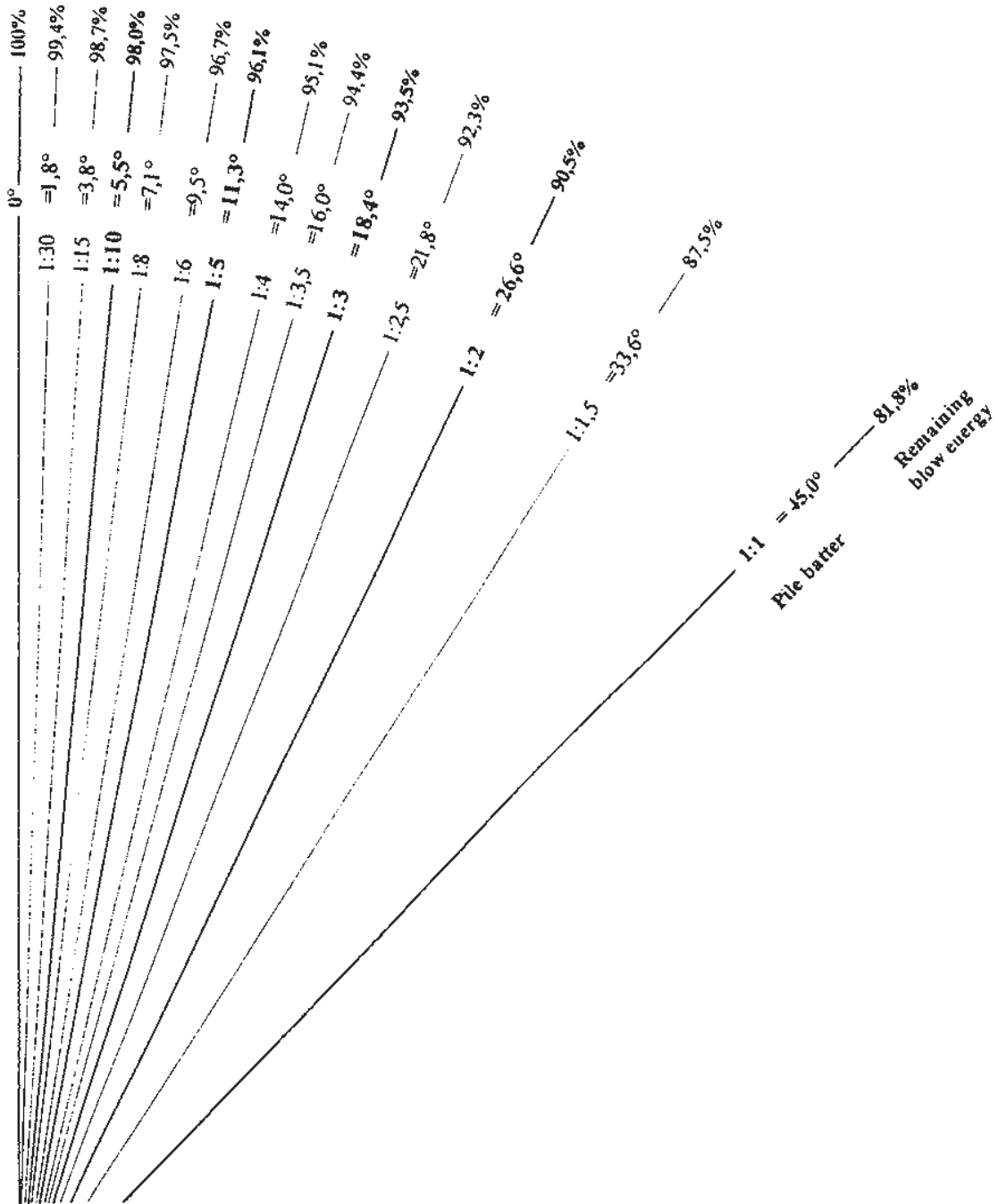

Assembly and disassembly of the cylinder extension

7.3 Assembly and Disassembly of the cylinder extension

When required, the upper cylinder section of Diesel pile hammers D16-32 through D100-13 can be extended. For these Diesel pile hammers, such an extension is required for a batter of more than 1:5.



Conversion work can be carried out only in the lower position! Let the Diesel pile hammer rest on the lower stop device or on the material to be driven! Danger to life!

Use a height safety device to prevent a fall (mandatory above 16 feet (5 meters), see Chapter 7.4 "Installation of the safety devices")!



Conversion work shall only be carried out by qualified and authorized experts!

Hard hat, safety boots and suitable work clothes must be worn! A life vest must be worn when working above a water surface!



Work stages:

1. Disassemble the upper end ring (24)! To do so, unscrew all hexagonal bolts of the upper end ring! Remove the upper end ring by lifting it upward!
2. Install the supplied extension for the upper cylinder section (1)!

3. Bolt the extension of the upper cylinder section (1) to the upper cylinder section (2)! Use the bolts of the upper end ring. Solidly tighten the bolts (Torque 750 Nm; 1500 Nm for D62 and higher, see also Chapter 12.2 "Screwed/Bolted connections")! Replace missing or damaged bolts or nuts with new ones!
4. Install the supplied extension for the lubricant line!

The disassembly of the extension is the reverse of the above!



Diesel pile hammers D16-32 through D100-13 shall be operated only with an installed upper end ring or extension of the upper cylinder section!

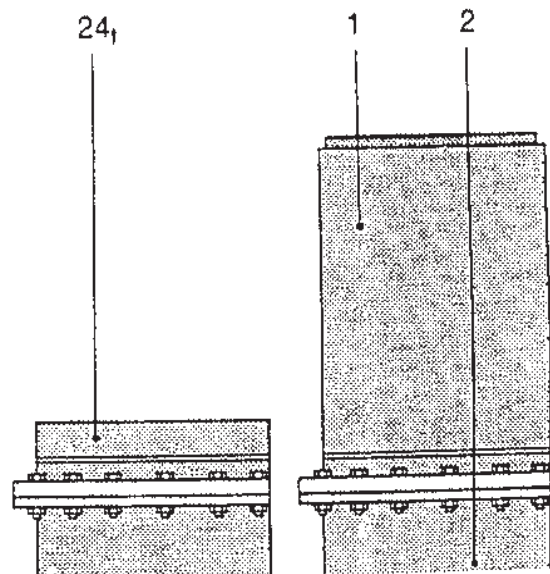

Installation of the safety devices

7.4 Installation of the safety devices

Height safety device

The height safety device is installed to prevent a fall! The use of a height safety device is mandatory above a lead height of 16 feet (5 meters)!

1. Install the unit at the location given by the lead manufacturer.
2. Attach one end of the supplied Perlon rope to the hook of the height safety device.
3. Attach the other end of the Perlon rope to the foot of the lead!



Do not keep the hook of the catch rope connected to the lead foot for a long time! This may over-stress the automatic coiling unit! The prevention of a fall is thus no longer ensured!

Use:

1. Wear a suitable safety belt!
2. Pull the catch rope down with the Perlon rope.
3. Properly attach the hook of the height safety device to the safety belt!

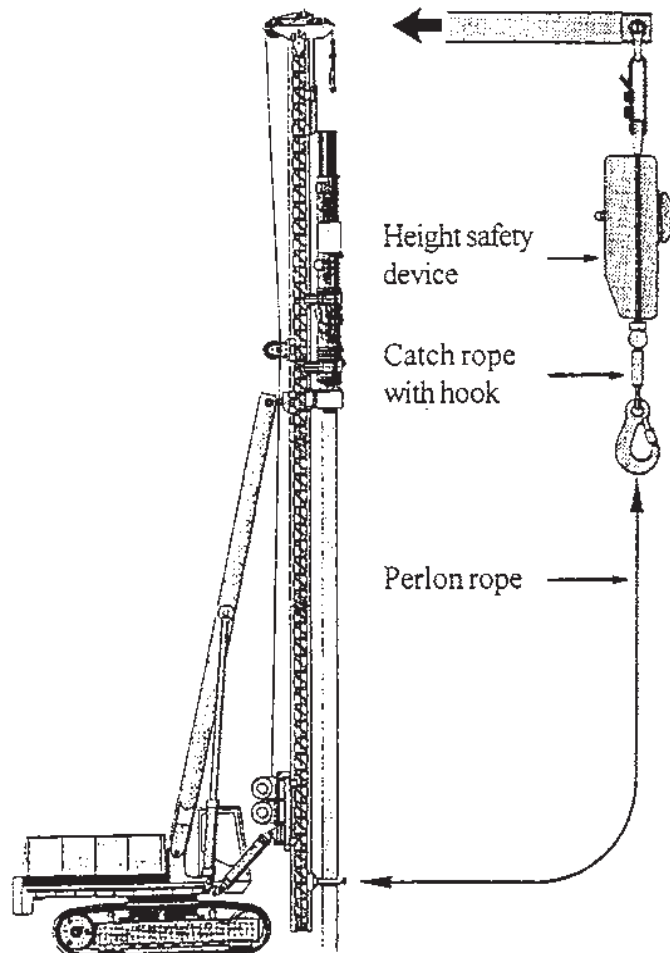

Support device

Support device

The support device is perfectly suited to support the Diesel pile hammer at a certain height at the lead. The Diesel pile hammer must be supported on the lower support device (or on the material to be driven) for conversion work and any other work carried out on the Diesel pile hammer.



You must follow the installation instructions provided by the manufacturer of the lead and support device! DELMAG will accept no liability for self-manufactured leads.

The Diesel pile hammer must be elevated sufficiently prior to putting it into operation! The respective support device is in that manner placed into the at-rest position! The rope for the support device must not be attached! This would prevent a return of the support device to the at-rest position! The support device and the guiding components would thus be destroyed when putting the unit into operation! Danger of a fall!

Use:

1. Use the tripping device to have the Diesel pile hammer rise to a point, at which it is located above the desired support device!
2. Pull downward on the rope at the support device and keep it taut!
3. Let the Diesel pile hammer slowly descend until it rests solidly on the desired support device!

4. Release the rope of the support device! The Diesel pile hammer now rests on the support device until the Diesel pile hammer is lifted with the help of the tripping device!

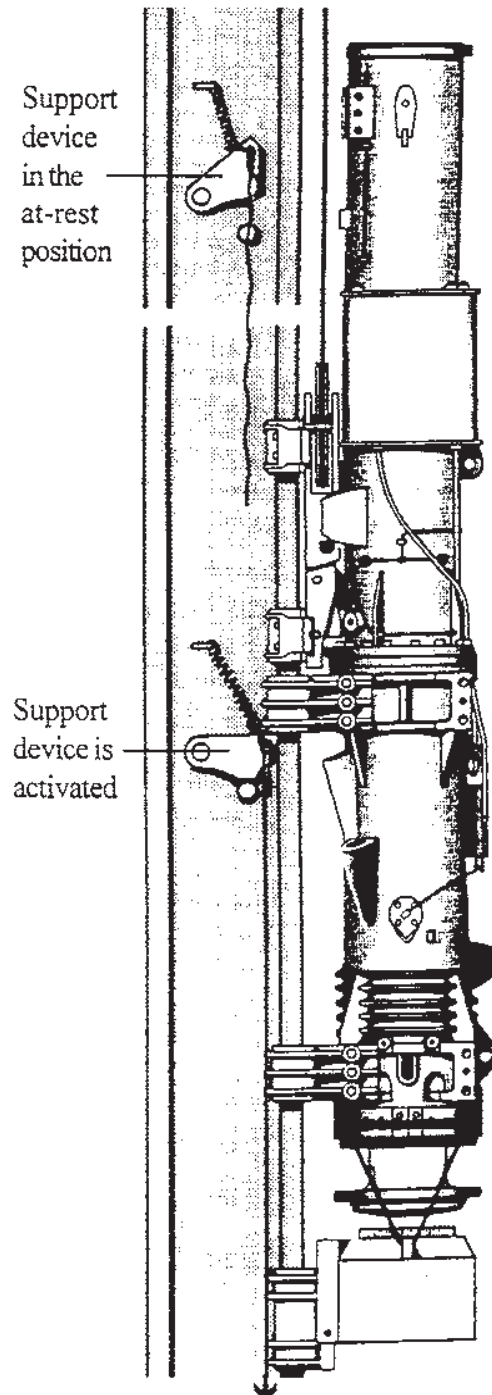

Pull until the Diesel pile hammer rests on the support

Bridle

Bridle

Unless a legislative body specifically asks for a certain type of safety device, the Diesel pile hammer can be secured by other means such as a bridle



The bridle should never be used to lift the Diesel pile hammer! The Diesel pile hammer should only be moved upward using the tripping device! This is the only way to ensure safe conditions for the Diesel pile hammer!

Follow the installation instructions issued by the manufacturer of the lead and bridle! DELMAG will accept no liability for self-manufactured bridles!

The bridle must be positioned approximately at the center between the upper and lower guide prior to putting the Diesel pile hammer into operation. The bridle must be adjusted continuously to match the driving progress. The bridle will be destroyed otherwise!

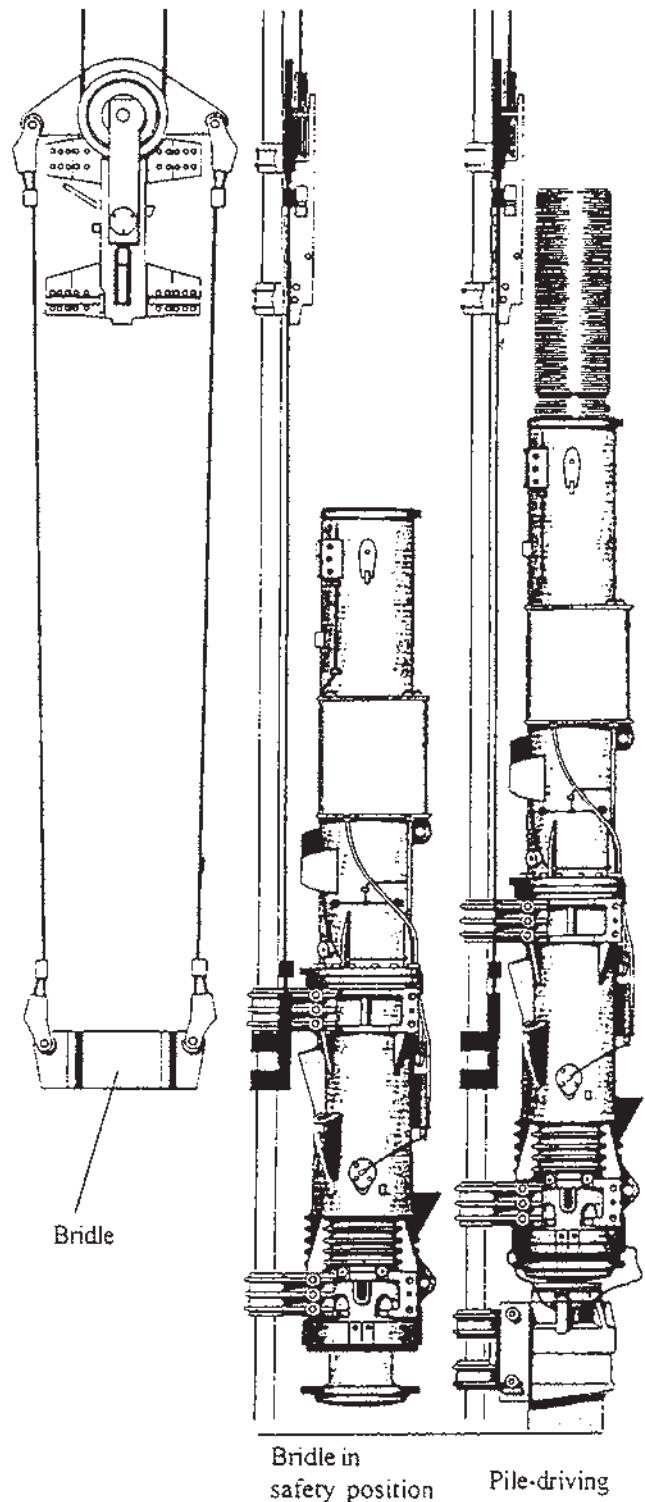

Piston replacement

7.5 Piston replacement

The following Diesel pile hammers can be converted to another type (see also Appendix A3 “Summary of pile hammer types”):

- D25-33 to D30-33
- D30-33 to D25-33
- D36-33 to D46-33
- D46-33 to D36-33

These Diesel pile hammers are fitted with two exhaust levels. One of the two exhaust levels is closed with a plug. To convert a unit, it will be necessary to replace the piston, move the exhaust plugs and to subsequently replace the pump element of the fuel control pump.

1. Replace the piston (See Appendix A3 “Summary of the pile hammers”)! To do so, disassemble the upper end ring or the extension of the upper cylinder (See Chapter 7.3 “Assembly and disassembly of the extension”)! Lift the piston, remove it at the top and install the new piston from the top (See Chapter 12.10 “Piston and impact block rings”)! Again install the upper end ring or the extension of the upper cylinder (See Chapter 7.3 “Assembly and disassembly of the extension”).
2. Remove the exhaust plug! To do so, tap the clamping pins from the exhaust plugs and pull the exhaust plugs from the exhaust opening!



Caution

Make sure neither the clamping pins nor other foreign objects fall in the exhaust opening! The impact area may be damaged otherwise when the unit is put into operation!

3. Check the sealing rings of the exhaust plugs! Replace damaged sealing rings with new ones!
4. Place the exhaust plugs into the respective exhaust openings!

Smaller impact weight	= decreased stroke volume	= lower exhaust level is open
Larger impact weights	= increased stroke volume	= upper exhaust level is open

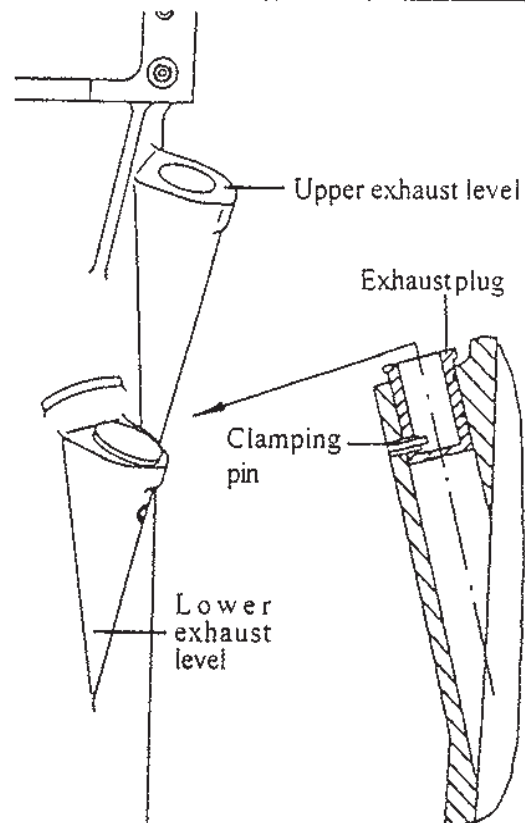

Assembly and conversion

5. Apply the clamping pins to the exhaust plugs
Check for a proper fit of the exhaust plugs!
6. Replace the pump element of the fuel control
pump (See also Page 12-10)!

Type	Pump element Diameter(mm)	Order No.
D25-33	20	66522
D30-33	22	65528
D36-33	24	64804
D46-33	27	64813



Caution

The upper end ring or the extension of the upper cylinder section must be in place when operating Diesel pile hammers of the types D16 through D46!

The smaller piston should never be used with the larger stroke volume (upper exhaust plane is open)! The piston weight may move upward too much and thus damage the Diesel pile hammer when starting the unit! Danger of an accident!

You must use the pump element intended for the respective Diesel pile hammer exclusively! An injection quantity that is too large may lead to accidents and to damage to the Diesel pile hammer!

Putting in operation

8. Putting into Operation



Danger

Carefully read and follow Chapter 3 “Safety measures” prior to putting the unit into operation!

All installation work required to put the unit into operation must be carried out by qualified and authorized experts!

8.1 Filling of lubricant lines with oil



Caution

The lubricant lines of the lubricant system must always remain filled with lubricant! Otherwise, the Diesel pile hammer will be supplied with the lubricant only after some time has passed! This will damage the Diesel pile hammer!

You must wear a hard hat, safety gloves, safety boots and suitable work clothes! Danger of injuries!



The lubricant lines of the lubricant system must be replenished prior to the first putting-into-operation and after repairs to the lubrication system:

1. Lay the Diesel pile hammer down in a horizontal position (See Chapter 5 “Transport”).
2. Remove the lubricant lines from the lubricant pump (Type D80 through D100: 2 lubricant pumps).

To do so, loosen the lubricant clamps!

Subsequently pull the lubricant lines from the connection fitting!

3. Fill the lubricant lines with motor oil using a squirt can (EO 20, 40 or 50 as a function of the application temperature; see Chapter 11 “Maintenance”)! Keep on filling the lubricant lines from the bottom with oil, until oil exits at all connection nozzles!
4. Push the lubrication lines back on the respective connection fittings!
5. Tighten the lubricant clamps again! Make sure all lubricant lines are solidly attached to the connection fittings (retighten, if necessary).
6. Put the Diesel pile hammer into a vertical position (See Chapter 5 “Transport”)!
7. Check the lubricant level in the lubricant tank! The tank must be full!

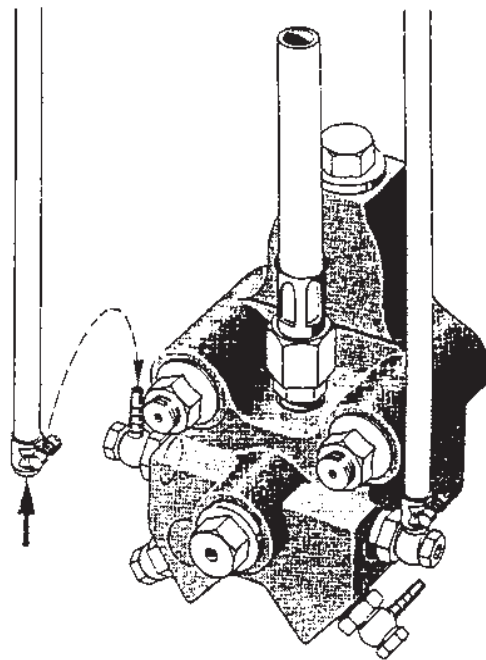

Motor oil as described in Chapter 11 “Maintenance”

Assembly of pile helmet cushions

8.2 Assembly of pile helmet cushions

The pile helmet cushion transfers the impact from the impact block to the material to be driven. A targeted assembly can dampen the impact to a certain degree (See Appendix A3 “Reduction factors for different pile helmet cushions”).

Assembly

1. Place the pile helmet cushion of the desired arrangement in the pile helmet (See Appendix A3 “Reduction factors for different pile helmet cushions”).

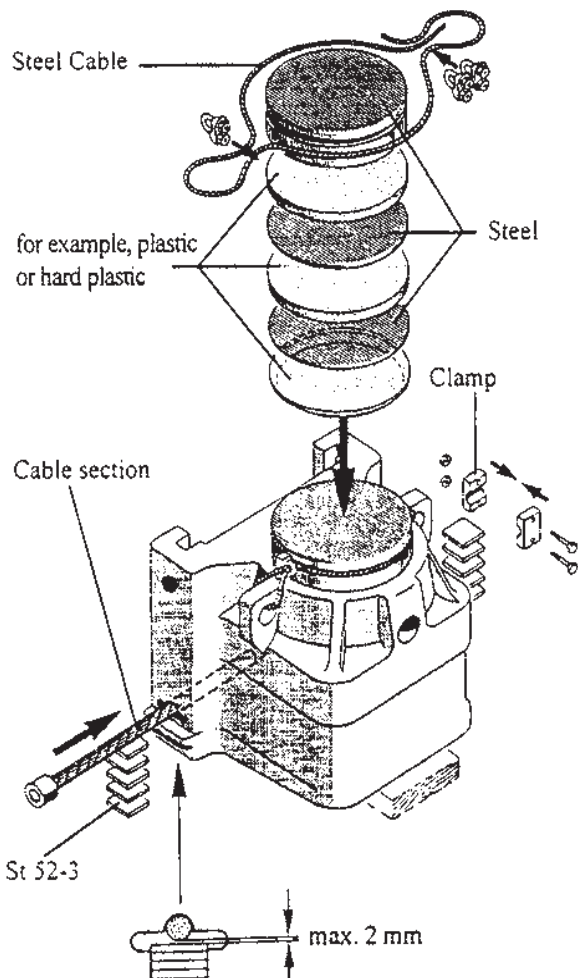

2. Attach the pile helmet cushion to the pile helmet! Use a suitable steel cable and the appropriate clamps to clamp the steel cable!
3. Guide the supplied cable section through the upper guide (This does not apply to pile helmets that are closed at the top)!
4. Secure the cable section with a clamp!
5. Insert the guide from the bottom into the pile helmet!

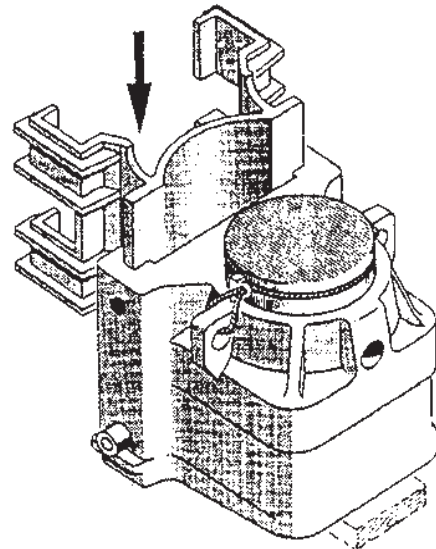

6. Insert the other supplied cable section in the lower guide!
7. Secure the cable section with a clamp!

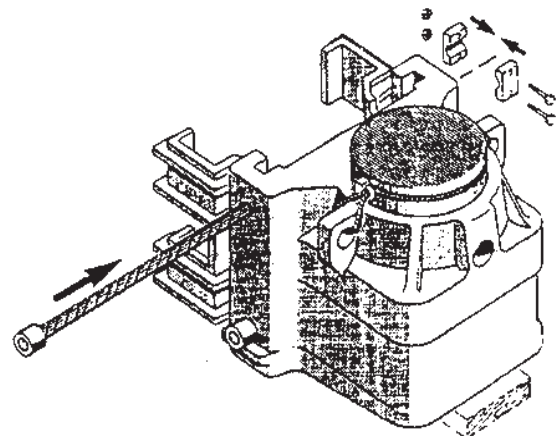

Guiding for the pile helmet

8. Insert as many plates below the lower cable section as it takes to have a spacing of not more than 2 mm between the lower cable section and the plates (See illustration on page 8-2)!
9. Make sure all bolts are tight (retighten, if required)!



Warning

All bolted connections must be tight! Loose bolts can cause serious injuries and property damage!

An incorrect attachment of the pile helmet cushion with the steel cable at the pile helmet can cause the cushion to fall out! Danger of an accident! This will invalidate the warranty!

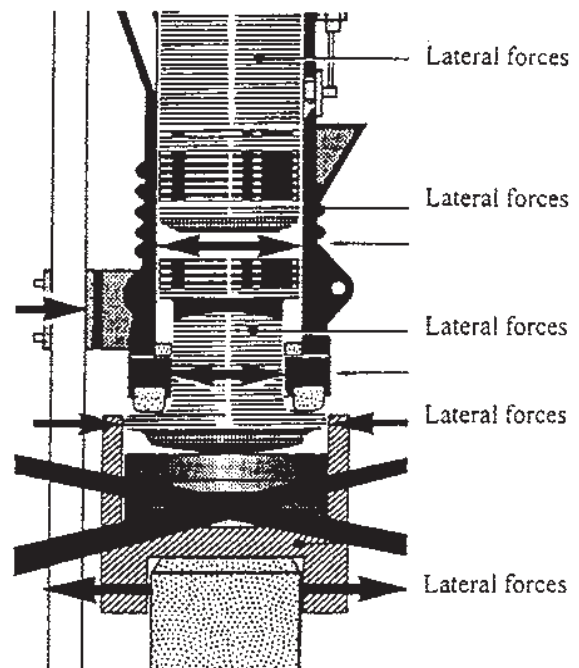

INCORRECT
(Lateral forces cause damage)

8.3 Guiding for the pile helmet

Always guide the pile helmet at the lead and never at the impact block of the Diesel pile hammer!



Caution

The pile helmet cannot be guided at the impact block of the Diesel pile hammer! Otherwise, lateral forces may cause damage to the impact block and the cylinder!

This will invalidate the warranty!

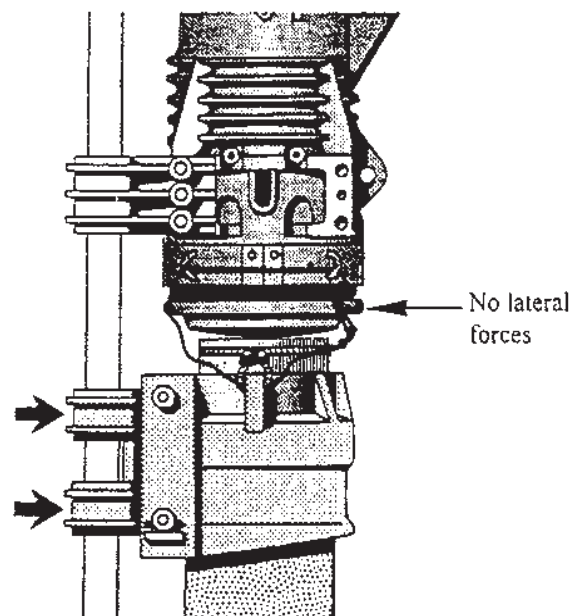

CORRECT
(Guided at the lead)

Bringing into the operating position of diesel pile hammer

8.4 Bringing into the operating position of Diesel pile hammer and pilehelmet

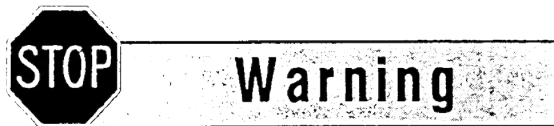

Observe the operating instructions of the carrier equipment!

Use only approved steel cables in accordance with Chapter 5.2 “Transport cables”! You must wear a hard hat, safety gloves, safety boots and suitable work clothes! A lifesaving jacket must be worn for work above a water surface!



1. Place the Diesel pile hammer in front of the lead! Observe the comments made in Chapter 5 “Transport”!
2. Loosen the bolts of the transport angles!
3. Lift the Diesel pile hammer 12 inches (30 cm) in a horizontal position (See Chapter 5 “Transport”)!
4. Remove the transport angles (See Chapter 5.1 “Transport safety”)!
5. Place the Diesel pile hammer on wooden blocks!
6. Remove the transport cables!
7. Place the steel cable loops around the lifting plates (3) and around the hook of the carrier equipment!
8. Carefully pull the Diesel pile hammer to a vertical position and place the Diesel pile hammer in front of the lead!
9. Install the two lower and one upper guide bracket (22)!
10. Lift the Diesel pile hammer 3 feet (1 meter)! Place the guide brackets (22)!
11. Install the second upper guide bracket (22)!
12. Place the pile helmet below the Diesel pile hammer!
13. Let the Diesel pile hammer rest on the pile helmet
14. Remove the locking screw (piston) (Type D80 through D100: 2 pieces) and the impact block clamp (See Chapter 5.1 “Transport safety devices”)!
15. Pull the Diesel pile hammer upwards until the impact block (19) is fully extended, then lower the hammer until you have approximately 6” to 8” of slack between the two piece rubber ring on the bottom of the hammer and the impact block. The impact block should never leave contact from the striker plate.
16. Attach the pile helmet to the cylinder end ring (17) as shown in the illustration! Use the steel cables and steel cable clamps from the tool chest!
17. Slowly lift the Diesel pile hammer while guiding the pile helmet through the lead!

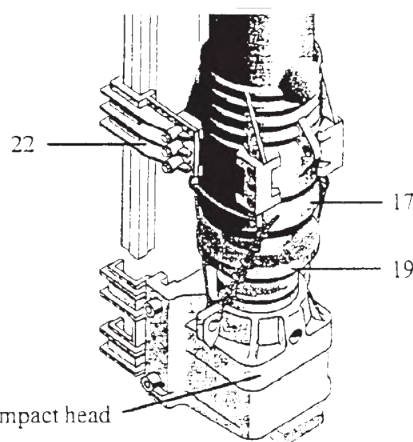

Bringing into the operating position of diesel pile hammer

18. Let the Diesel pile hammer rest on an integral stop device of the lead (See Chapter 7.4 "Installation of the safety devices")!



The Diesel pile hammer shall be operated only with installed and operating safety devices (See Chapter 7.4 "Installation of the safety devices")! The Diesel pile hammer may suddenly fall when this is not observed! **Danger to life!**

19. Remove the steel cable loops from the lifting plates (3) and from the hook of the lifting equipment!
20. Attach both ends of the 230 feet (70 m) long control cable (in the tool box) to the eyelets for the control cable of the fuel control pump (12)!
21. Attach the 115 feet (35 m) long rope to the shutoff valve (center eyelet) of the fuel control pump (12)!
22. Fill the fuel tank with Diesel fuel (See Appendix

A3 "Usable fuels" for alternate fuels). The filling nozzle of the tank indicates "Diesel".

It is important to use a fuel that is suited for the predominant temperature conditions (See the following table)! If this is ignored, the unit may be difficult to start and the fuel lines may become clogged!

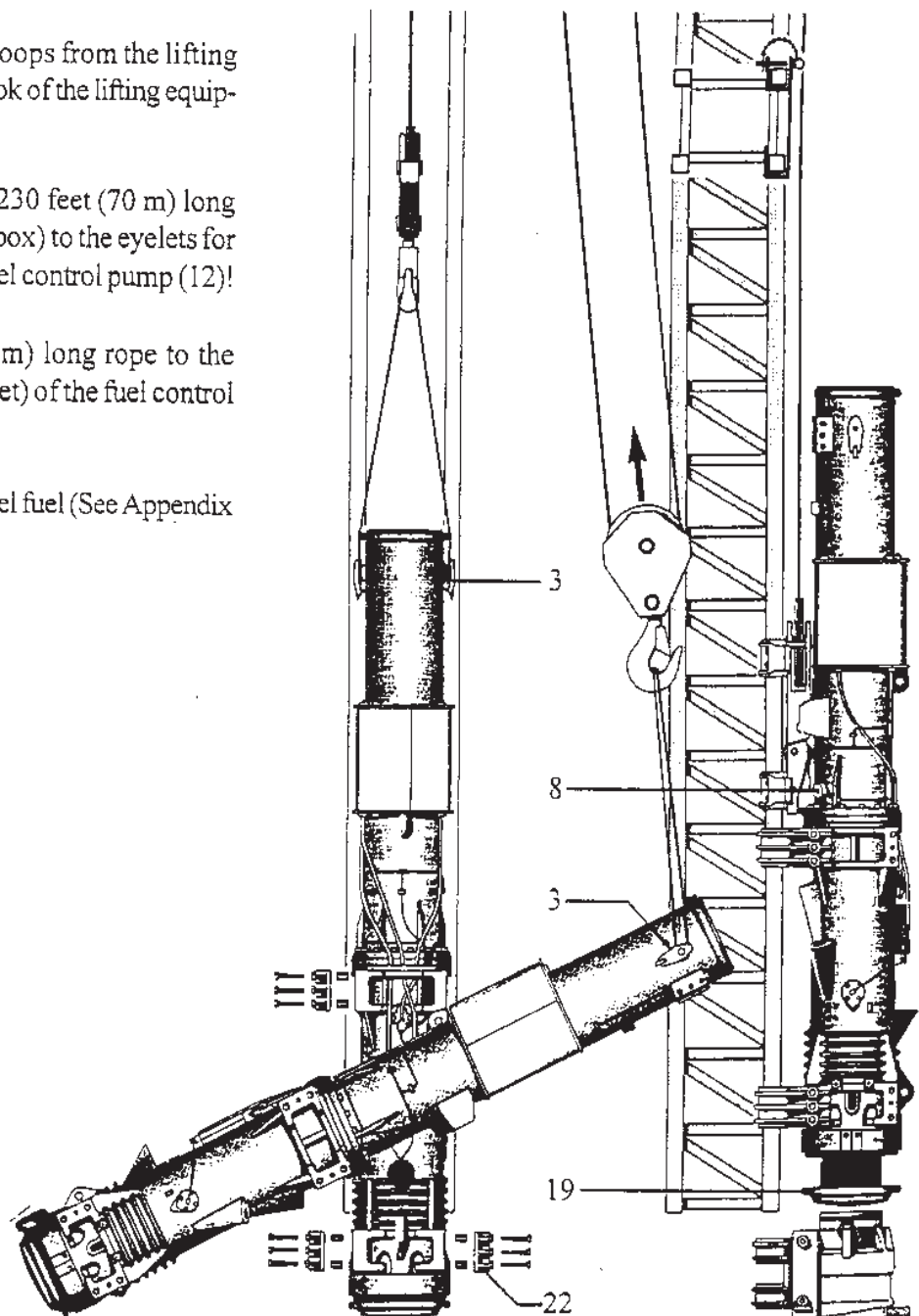
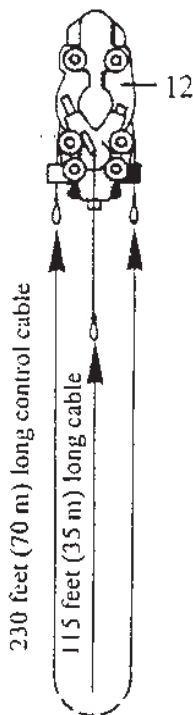

Lifting of piles

Mixing ratio Diesel / regular gasoline
or engine mineral oil

Outside temperature	Summer Diesel fuel	Winter Diesel fuel
above -10 °C	90% / 10%	100% / 0%
-10 °C to -14 °C	70% / 30%	100% / 0%
-14 °C to -20 °C	50% / 50%	80% / 20%
-20 °C to -30 °C	—————	50% / 50%

23. Fill the lubricant tank with lubricant (Oil type as described in Chapter 11 “Maintenance”) The filling nozzle of the lubricant tank shows “Oil”!
24. Remove the transport safety devices (protective hood, protective rail, exhaust cover; see Chapter 5.1 “Transport safety”)!

8.5 Lifting of piles



Follow the operating instructions of the carrier equipment!

Use only approved steel cables in accordance with Chapter 5.2 “Transport cables”!

Observe the following information to prevent an overturning of the unit and damage to the lead and material to be driven!

You must always wear a hard hat, safety gloves, safety boots and suitable working clothes! You must wear a lifesaving vest when working above a water surface!



Never pull the material to be driven from the lead tip! This may cause an overturning of the carrier unit or may bend the lead end!

Always turn the unit in the direction of the impact point of the material to be driven! The inclined pulling force may cause the unit to overturn!

The material to be driven must always be lifted in such a manner that

- there is no permanent deformation,
- no cracks form in the material to be driven,
- the material to be driven hangs vertically after lifting it.

This achieves the following:

Lifting of piles

- The piles can be placed in an optimal manner,
- Sheet piles can be guided properly,
- The pile helmet is easy to place above the pile head.

Concrete piles and similar sensitive material to be driven must be treated with particular care!

The following illustrations show correct and incorrect ways to lift the material to be driven with one or two cables.

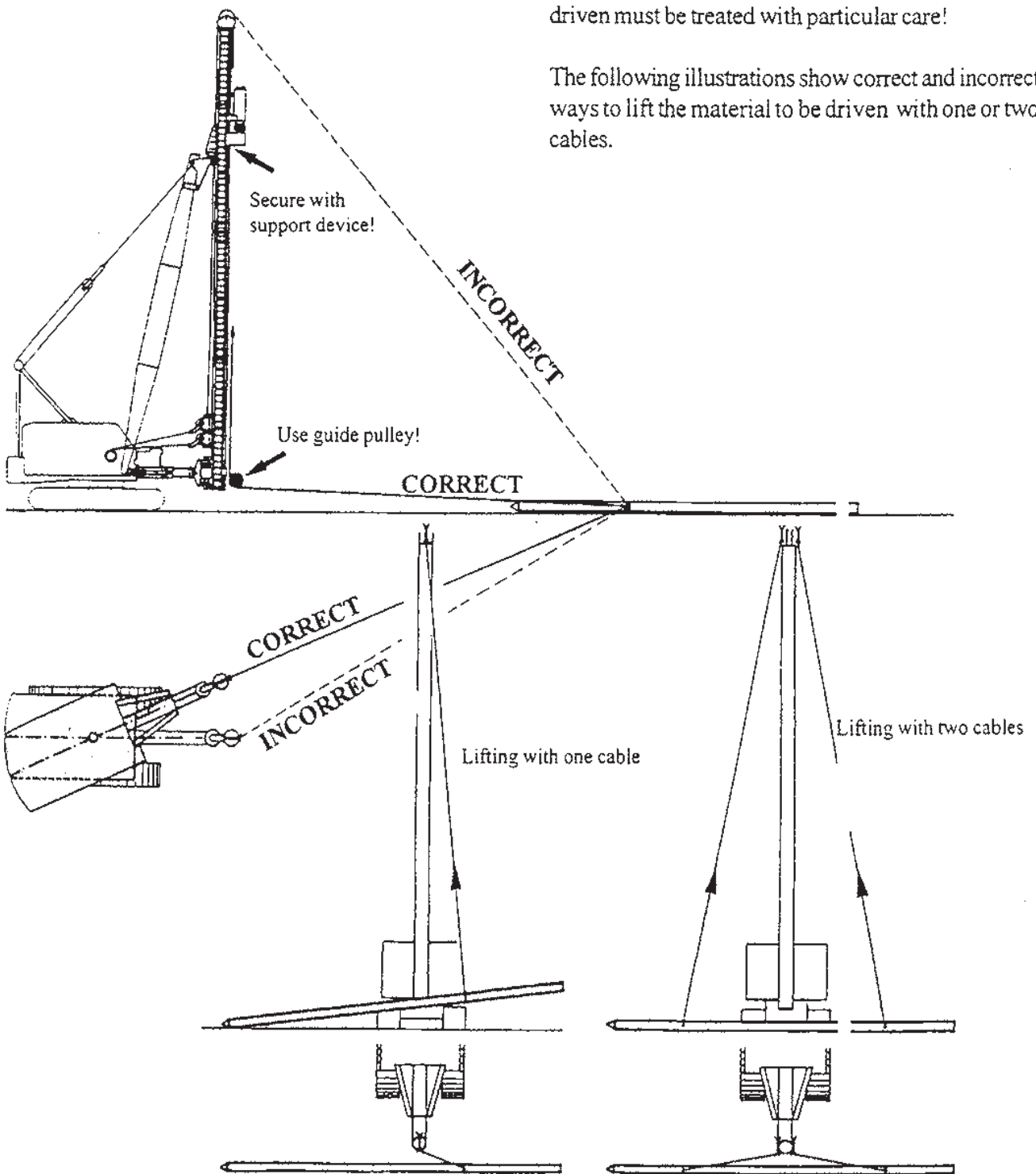

Lifting of piles

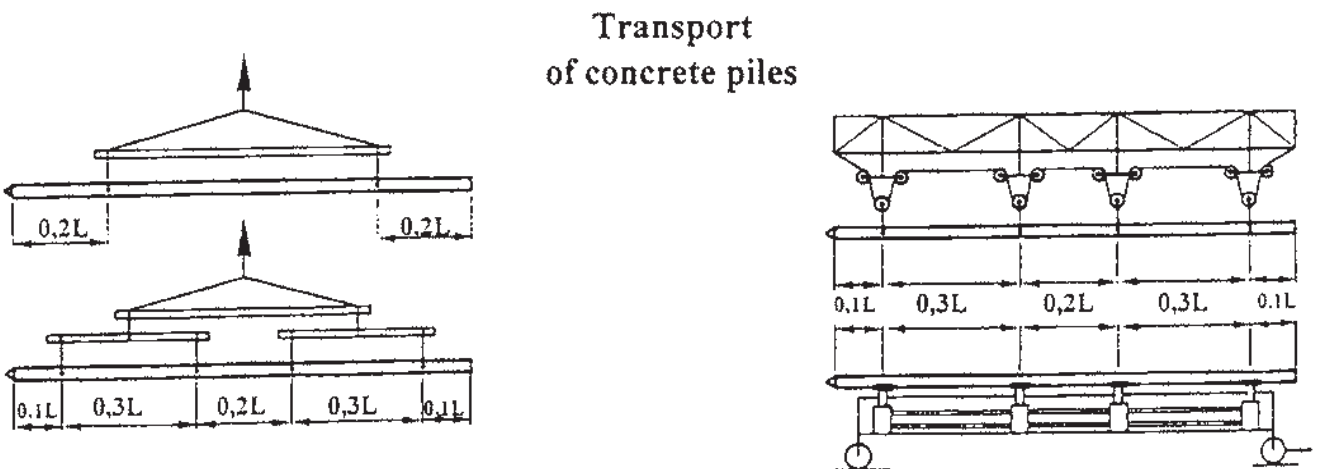
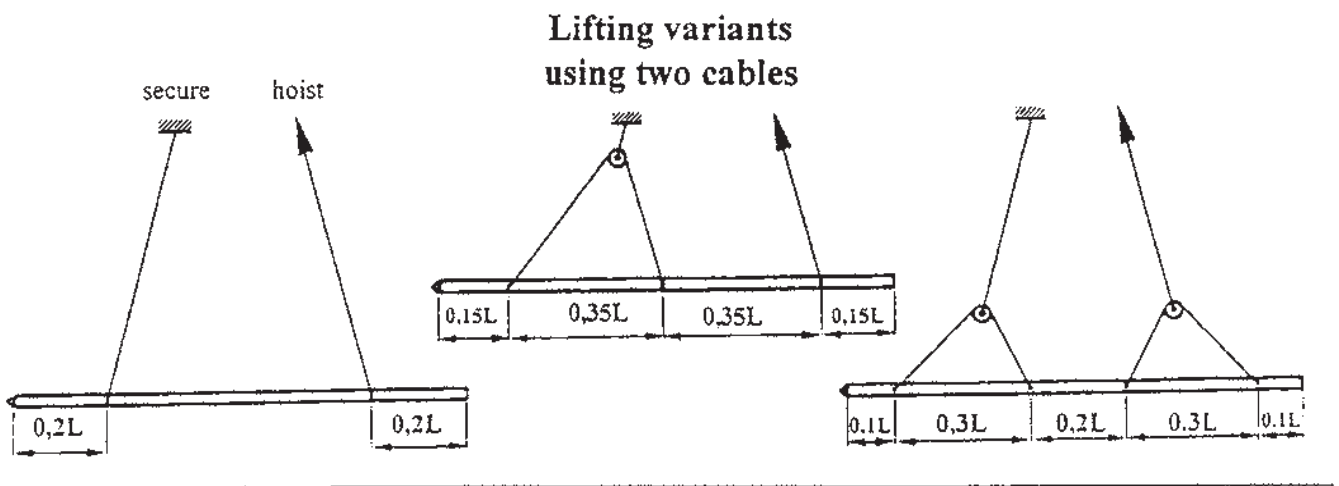
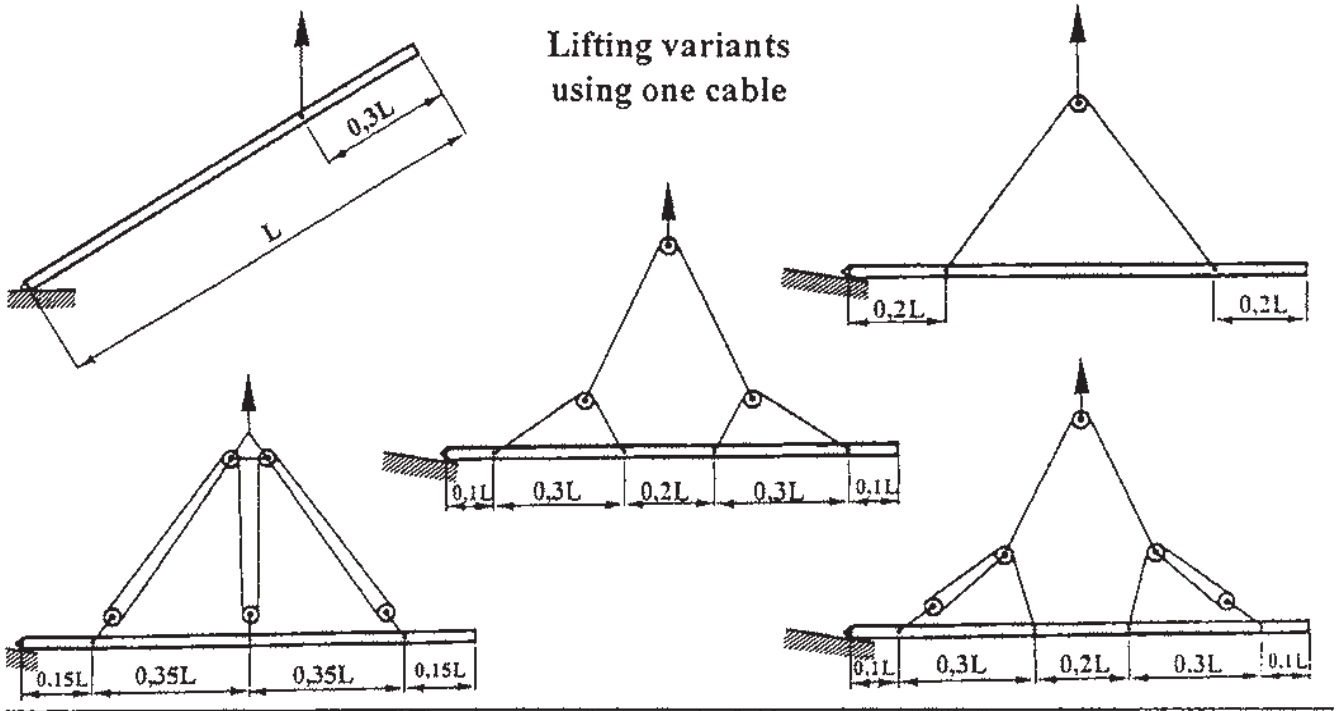

The bending moments on the concrete pile must be kept to a minimum during the transport.

The hydraulic cylinders are coupled to equalize the support forces.

Tripping device

8.6 Tripping device

The tripping device is an auxiliary means

- to lift the Diesel pile hammer at the lead,
- to lower the Diesel pile hammer at the lead,
- to lift the piston when starting the Diesel pile hammer.

The tripping device is operated with the help of a winch on the carrier equipment or hydraulically.

Installation



Danger

You must use the tripping device supplied by DELMAG! Check the tripping device for damage prior to its installation! Use only tripping devices that are technically perfect! Danger to life!

Use a height safety device to prevent a fall (mandatory at a lead height of above 16 feet (5 meters), see Chapter 7.4 "Installation of safety devices")! Danger of a fall!

Use only approved steel cables (See Chapter 5.2 "Transport cables")!



Warning

Follow the operating instructions for the carrier equipment

You must wear a hard hat, safety gloves, safety boots and suitable work clothes.

You must wear a lifesaving vest when working

above a water surface !



1. Attach the two lower and one upper guide strip to the tripping device!
2. Place the steel cable in the cable pulley! To do so, you must remove the cable pulley bolt and install it again when the steel cable is positioned!



Warning

Use the bolt safety to secure the cable pulley bolt after its re-installation! Danger of an accident!

3. Lift the tripping device and place the guide gibs!
4. Install the second upper guide gib!
5. Attach the 115 feet (35 meters) long cable (in the tool box) to the lever (A2)!



Warning

Use only the safety pulling cable supplied by DELMAG! We cannot guarantee a proper functioning with the use of other cable!

6. Pull the tripping device upward for approximately 19 feet (6 meters) (See illustration on page 8-10)!

Operational test

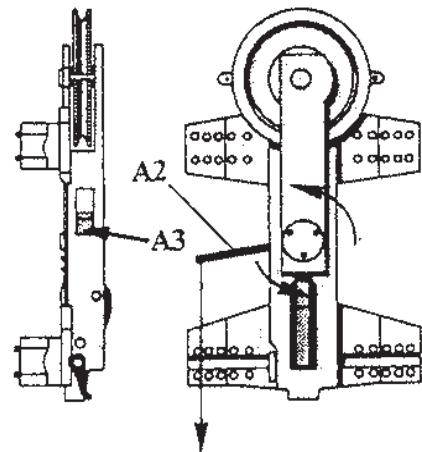
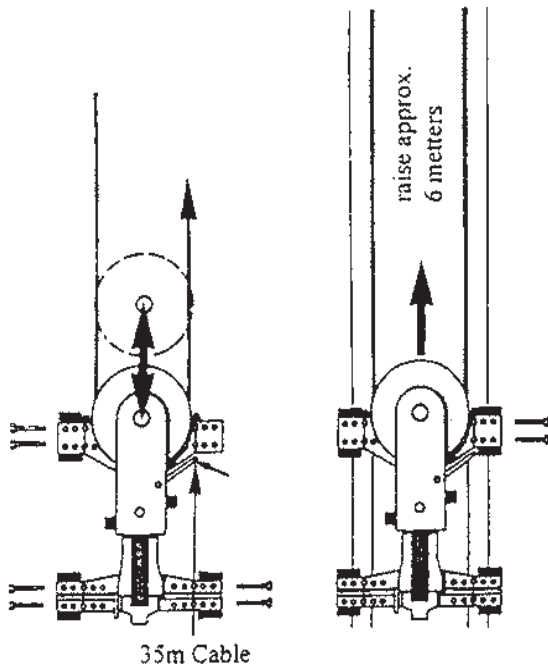

- Lower the tripping device to the lower stop (9)! The trip cam lever (A5) is pushed upward at the trip cam lever engaging point (9). Pawl (A4) is thus pushed into the groove of the piston weight (26).

Operating mode



You must keep a distance of at least 13 feet (4 meters) from the Diesel pile hammer! Wear a hard hat, ear plugs, safety goggles, safety gloves, safety boots and suitable work clothes! A life saving vest must be worn when working above a water surface!



Lowering the tripping device

- Pull the lever (A2) down to the stop using the cable and keep it taut! This retracts the driving pin (A3). The tripping device can move past the latches of the Diesel pile hammer.

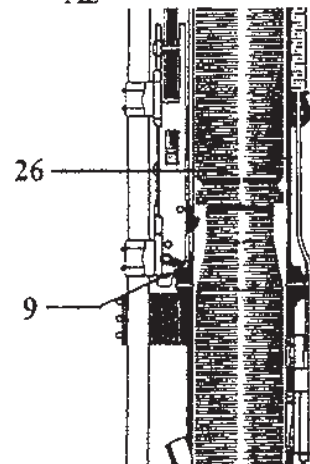
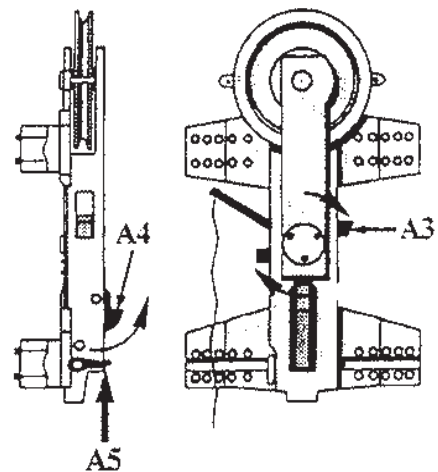

Operational test

3. Release the cable at the lever (A2)!



Danger

The tripping device must always be lowered to the lower stop to ensure that the latch projects fully and is locked. If this is omitted, the Diesel pile hammer may trip prematurely! Danger to life!

The pulling cable must always hang free! Do not tie the pulling rope to the lead or other places! This may cause the Diesel pile hammer to crash down! Danger to life and risk of a destroyed tripping device!

Lift / lower Diesel pile hammer

1. Lower the tripping device as described above!
2. Slowly pull the tripping device upward using the cable winch! Do not pull on the cable at the lever (A2)! During the lifting stage, the cams of the rotating catch (A3) grasp below the catch (6) of the Diesel pile hammer. The Diesel pile hammer now hangs from the tripping device.



Caution

Pay attention to the fact that the piston has indeed fallen into a notch of the tripping device during the lifting of the Diesel pile hammer!

3. Use the cable winch to place the Diesel pile hammer into the proper position!

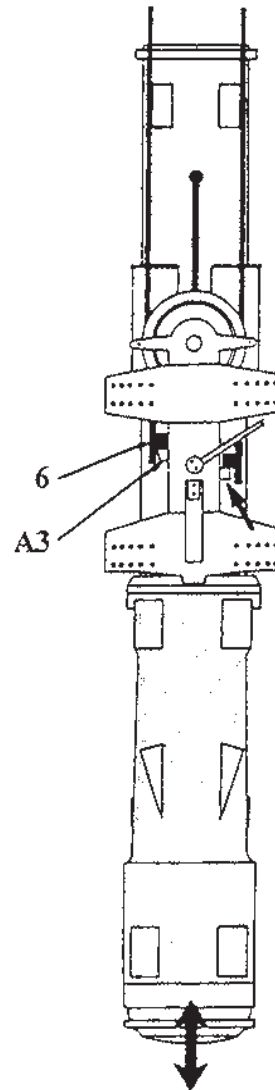

Lifting the impact hammer

1. Lower the tripping device as described above!
2. Pull the lever (A2) down to the stop using the cable and keep the cable taut! This retracts the rotating latch (A3).

Fuel supply control

3. Use the cable winch to slowly pull the tripping device upwards! When pulling it upwards, the piston (26) is also pulled upward and automatically released at the upper stop (21).

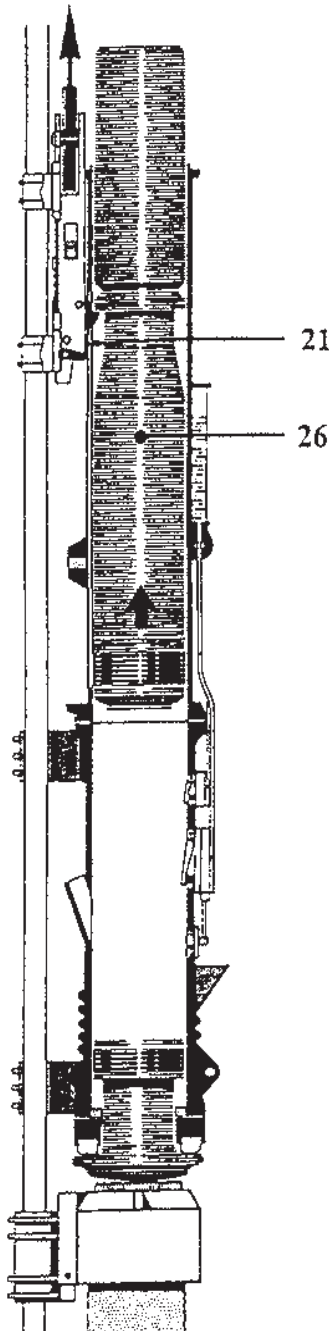

8.7 Fuel supply control

The fuel supply control pump determines the energy per blow and thus the drop height of the piston. The fuel control pump has five settings: Setting "1" (lowest energy, 48%-64% as a function of the type) to Setting "4" (highest energy = 100%) as well as Setting "0" (no fuel supply = shutoff). See Chapter 9.2 "Setting of the blow energy"! In addition to using Setting "0", the fuel supply can also be cut off with the shutoff valve.

Mode of operation



You must keep a distance of at least 13 feet (4 meters) from the Diesel pile hammer! Wear a hard hat, ear plugs, safety goggles, safety gloves, safety boots and appropriate work clothes! A life-saving vest must be worn when working above a water surface!



Increase fuel supply

Jerk on the right rope to the stop and release the cable! This switches the fuel control pump to the next higher setting. Repeat this step until the desired setting has been reached (to the maximum Setting "4")!

Decrease fuel supply

Jerk on the left rope to the stop and release the

Bleeding of fuel control pump and injection valves

able! This switches the fuel control pump to the next lower setting. Repeat this step until the desired setting has been reached (to a maximum setting of “0”).

Fuel supply shut-off

Pull on the center rope to the stop and keep the cable taut until the impact hammer is at rest! This has no effect on the setting of the fuel control pump.

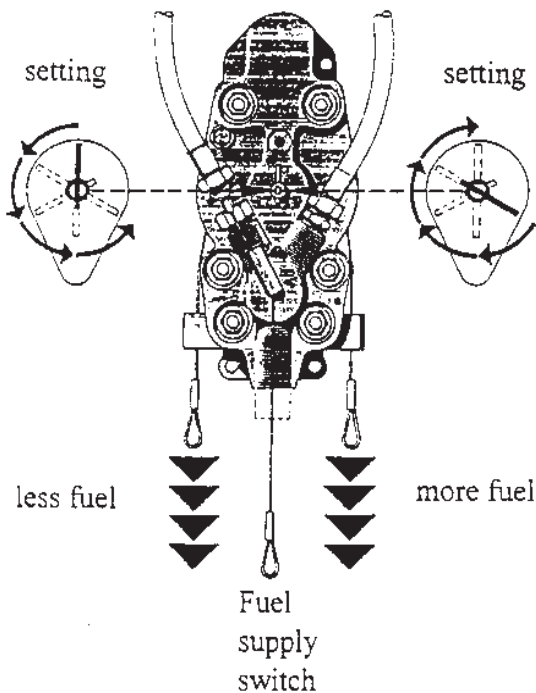

Bleed fuel control pump and injection valves

The fuel control pump and the injection valves (Type D5 through D30: only one injection valve) must be bled

- prior to the first putting-into-operation,
- after repair work,
- when the Diesel pile hammer fails to operate due to a lack of fuel.

Take the following measures:



Use a height safety device to prevent a fall (mandatory at a lead height of above 16 feet (5 meters), see Chapter 7.4 “Installation of safety devices”)! **Danger of a fall!**

Let the Diesel pile hammer cool down fully prior to the bleeding (particularly in the event the Diesel pile hammer stopped working due to a lack of fuel)! **Danger of burns and fire!**

You must wear a hard hat, safety gloves, safety boots and appropriate workclothes. You must wear a lifesaving vest when working above a water surface!



1. Pull the piston upward until the trip cam lever (A5) of the tripping device is located approximately 8 inches (20 cm) below the release point (21) (See Chapter 8.6 “Tripping device, lifting of the impact hammer”)! **The fuel flow to the fuel control pump will be blocked, when the impact hammer is too low. The impact hammer will be released automatically, when the impact hammer is pulled too far upward!**
2. Set the fuel control pump to Setting “4” (full load)!
3. Unscrew the swivel joint at the injection valves (Pos. 13, Type D5 through D30: only one injection valve) by approximately 2-3 turns! **Do not fully unscrew the swivel joint!**

Cleaning of combustion chamber

4. Activate the pump with the right control rope until a fuel without bubbles exits at all swivel joints (Types D5 through D30: only one swivel joint)!
5. Keep the control rope taut and at the same time tighten all swivel joints (Types D5 through D30: only one swivel joint)!
6. Release the control rope!
7. Pull on the center rope for approximately 5 seconds! This opens the shutoff valve. Air can escape into the tank by way of the fuel lines.
8. Release the center rope!
9. Repeat steps 3 through 8 three times!

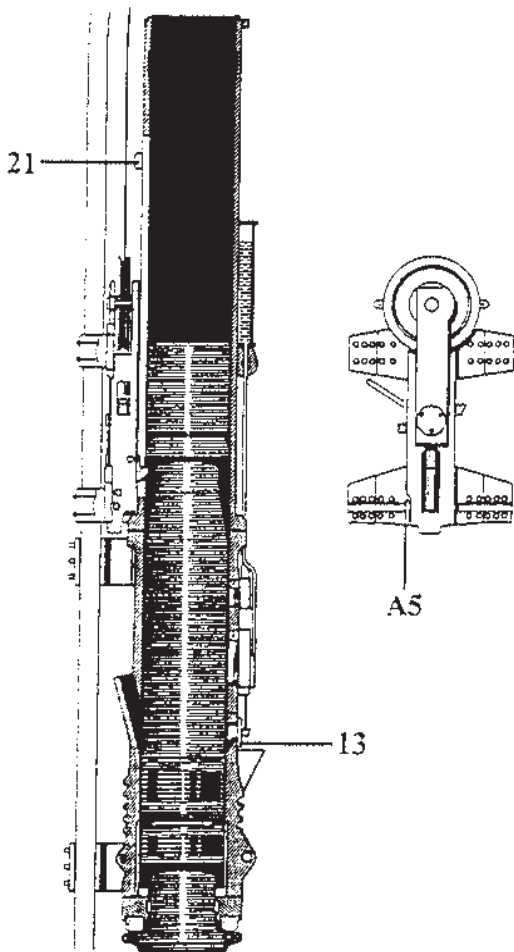

8.8 Cleaning of combustion chamber



Caution

The combustion chamber must be cleaned each day **prior** to the first startup of the Diesel pile hammer. When this is omitted, the lubricant that has accumulated in the combustion chamber would also ignite during starting. The impact hammer may bounce to the catch groove (25) and cause damage.

Take the following steps:



Warning

The Diesel pile hammer must rest on a pile or on the ground (with an appropriate support)! It must never rest on a support device. If this is not observed, the support device will be destroyed and the Diesel pile hammer comes crashing down! Maintain a distance of at least 13 feet (4 meters) from the Diesel pile hammer! Never stand in front of the Diesel pile hammer with a open combustion chamber bolt! Fuel, oil, dirt and material residues will be ejected at a great pressure! This could cause injuries to the eyes or skin as well as burns and poisoning!

You must always wear a hard hat, ear plugs, safety goggles, safety gloves, safety boots and suitable work clothes!.



1. Set the fuel control pump to the setting "0"! To do so, pull the left control cable as often as required!

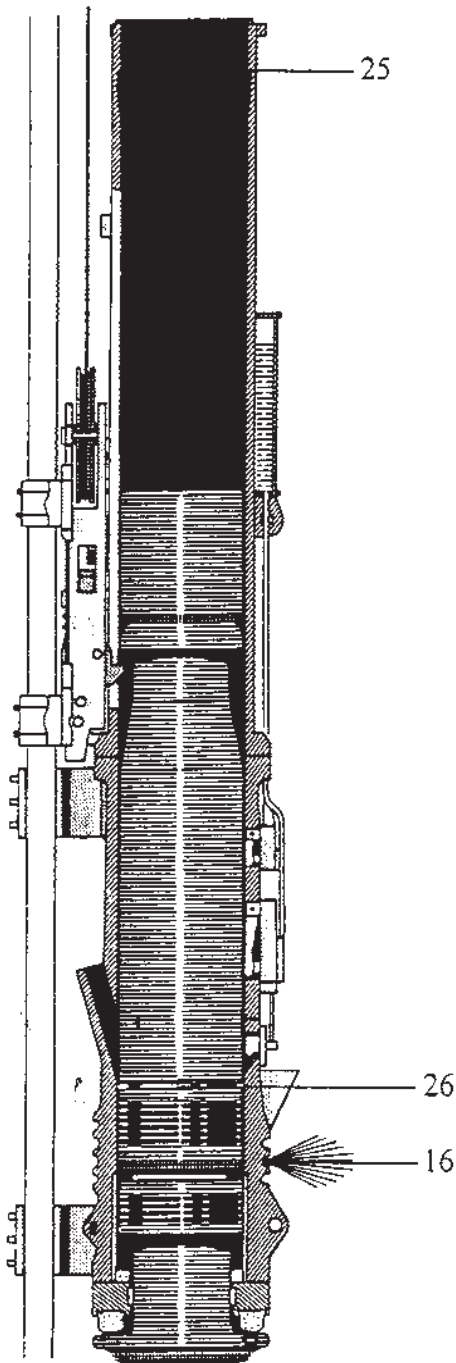

2. Remove the blow out plug (16)!
3. Maintain a safe distance from the Diesel pile hammer, since dirt and material residues will be ejected at a high pressure!

Never stand in front of the combustion chamber opening of the Diesel pile hammer. Always stand to the side of it!

4. Raise the piston five times using the tripping device and let the piston catch at the upper stop (See Chapter 8.6 "Tripping device")! These cold blows allow oil and dirt to escape from the combustion chamber.
5. Screw the plug (16) back in.

8.9 Start and control



Danger

Follow all safety measures described in Chapter 3!

Thoroughly inspect the whole driving equipment system prior to putting it into operation! Check the unit for loose screws and bolts, cracks, wear, leaks and damage caused by vandals! Check the stability of the unit! Make sure all damages are repaired immediately! Operate the equipment only after all damages have been repaired (See Chapter 11 "Maintenance")!

With the exception of the excavator operator, operator and the foreman in charge of the pile driving, make sure no other person stands within a distance of 1.5 times the lead height! Sound a horn to warn others of the impending putting-into-operation of the unit!

Start and control

Immediately halt the driving process in the event of a dangerous situation! Place a sign “Attention: Diesel pile hammer is out of order!” (Supplied with the tool chest)! Operate the Diesel pile hammer only after the dangerous situation has been taken care of!



The Diesel pile hammer should never rest on the support device! The support device will be destroyed and the Diesel pile hammer will come crashing down!

The piston should not bounce into the catch groove (25). The Diesel pile hammer must be shut off immediately in this case! Thereafter, operate the Diesel pile hammer only

- after checking or replacing the screws used to fasten the upper end ring or the extension of the upper cylinder section,
- after checking or tightening the catch groove,
- after checking the catch piston ring!

You must keep a distance of at least 13 feet (4 meters) from the Diesel pile hammer! Wear a hard hat, ear plugs, safety goggles, safety gloves, safety boots and appropriate work clothes!



Procedure

1. Set the fuel control pump to the setting “0”! To do so, pull on the left control rope as often as required (See Chapter 8.7 “Fuel supply control”)!
2. Using the tripping device, pull the impact hammer upward and release it (See Chapter 8.6 “Tripping device”)!
3. **For a pre-driven pile:** Set the fuel/control pump to the setting “2” after the first blow! To do so, jerk the right control rope twice!
For a newly placed pile: Set the fuel control pump to the setting “3” after the first blow! To do so, jerk the right control cable three times!
4. Continuously adjust the fuel injection quantity by jerking the control cables. Do not increase the injection quantity faster than one step per stroke!

Operation - pile driving

9. Operation

9.1 Pile driving



Danger

Follow all safety measures described in Chapter 3!

Operate the Diesel pile hammer and lead only when they are in a perfect technical condition! Particularly the guiding components and tripping device should show no signs of wear! Danger to life!

Immediately halt the pile-driving operation when a dangerous situation develops (e.g., when unauthorized persons enter the danger zone or in the event of damage)! Operate the Diesel pile hammer only after the dangerous situation has been taken care of!

Do not carry out any repair or maintenance work on a moving Diesel pile hammer!



Warning

No person should stand closer than 13 feet (4 meters) from the operating equipment! No unauthorized person should be within a danger zone of 1.5 times the lead height! Said zone must be blocked off and designated with signs written in the language spoken on the job site!

Example:

MH 32103
at hydraulic excavator
Caterpillar 245

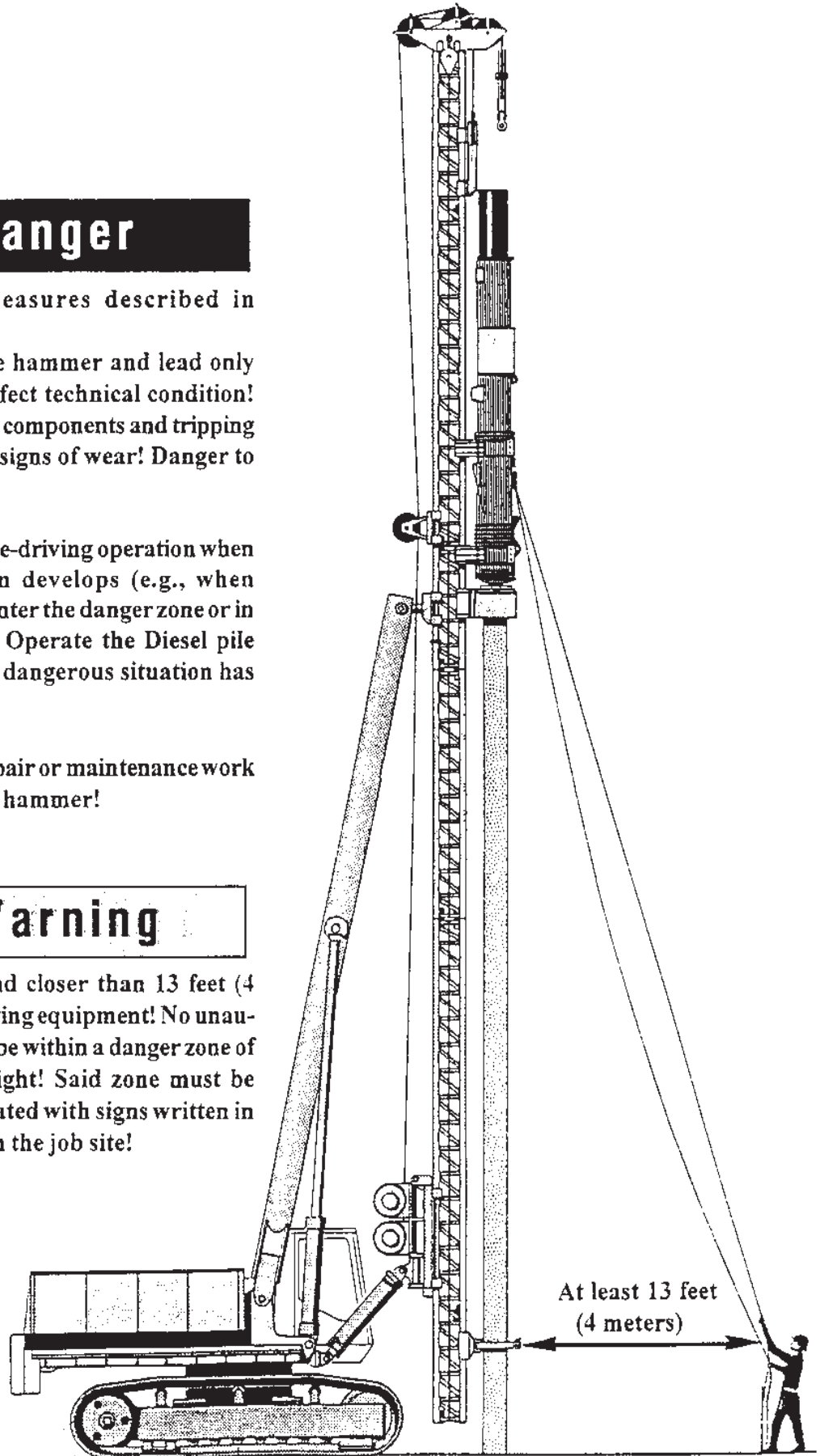



Warning

The Diesel pile hammer should never rest on the support device during operation! The support device will be destroyed and the Diesel pile hammer will come crashing down!

The piston shall not bounce into the catch groove! This may damage the catch ring piston, catch groove and attachment screws! The safety of the Diesel pile hammer is thus no longer ensured!

When using a bridle, the bridle must be adjusted continuously to the piling progress! The bridle will be destroyed otherwise! The safety against a fall is no longer ensured!

You must always wear a hard hat, ear plugs, safety goggles, safety gloves, safety boots and suitable work clothes!.



Caution

The combustion chamber must be cleaned each day prior to the first startup of the Diesel pile hammer. When this is omitted, the lubricant that has accumulated in the combustion chamber would also ignite during starting. The impact hammer may bounce to the catch groove and cause damage.

Make sure the impact block never hangs out or gets stuck! The Diesel pile hammer does not properly rest on the impact head when the impact section is hanging out (e.g., with sticking guides). This will cause damage to the end ring

and cylinder! With a sticking impact block, the cylinder is unable to freely drop on the impact head unit (possibly due to defective damping rings)!

Piles should never be driven eccentrically! This may cause damage to the cylinder and guide components as well as damage and vibrations to the material to be driven!

Make sure the allowable batter is not exceeded when driving batter piles (See Chapter 7.2 "Conversion to drive batter piles")! Make sure the Diesel pile hammer is maintained regularly and properly (See Chapter 11 "Maintenance")!

Stop the diesel pile hammer if the penetration rate is less than 0,8 in per 10 blow. Lower penetration is possible, but it causes higher wear of the diesel pile hammer. Make sure that maintenance of the diesel pile hammer is carried out regularly and expertly.

Blow area

A perpendicular and plane blow area is required for a perfect driving of piles. The center line of the material to be driven must be in line with the center line of the Diesel pile hammer. This is necessary to avoid jarring blows. Jarring blows could cause

- cracks in and deformation of the cylinder.
- vibrations in and damage to the material to be driven,
- directional deviation for the material to be driven,
- increased wear in the guide components.

Remedy: Use an pile helmet that is guided at the lead and matches the pile profile! Use an pile helmet cushion selected in an optimal manner with respect to the material to be driven and to the blow energy (See Chapter 9.2 "Blow energy stages" and

Shut off

Appendix A3-1 “Reduction factors for different impact head cushions”)! When it is impossible to guide the pile helmet at the lead, it will be necessary to hold the material to be driven at the lead with at least one pile guide!

Deviations from the original directions of the material to be driven can also occur under the best conditions! Accordingly, it will be necessary for the foreman in charge of the pile driving work to continuously monitor the pile driving phase and to have the lead corrected, when required!

Observe the maintenance intervals (See Chapter 11 “Maintenance”)!

Shutting off

Pull the center rope (at the shutoff valve) and keep it taut until the piston is completely at rest!

The Diesel pile hammer can also be shut off by setting the fuel control pump to the setting “0”! To do so, jerk the left control rope as often as required!

9.2 Blow energy stages

The blow energy is adjusted to the respective blow conditions by controlling the fuel supply (See Chapter 8.7 “Fuel supply control”). The fuel control pump has five settings: Setting “1” (lowest energy, 48%-64% as a function of the type) to Setting “4” (highest energy = 100%) as well as Setting “0” (no fuel supply = shutoff).

The blow energy of the respective type at different settings can be taken from the table shown below! You must be aware of the following:

- The given values are measured values. Deviations are possible between Diesel pile hammers of the same type.

- The given blow energy is obtained only for vertical driving work. For batter piles, the blow energy is reduced as a function of the batter (See Chapter 7.2 “Conversion for batter piles”).
- The injection quantity is not proportional to the blow energy, because the fuel is burned at different degrees of efficiency. For example: 50% of the injection quantity does not reduce the blow energy by exactly 50%!

Shutting down and leaving in lead

10. Shutting down and storage

10.1 Shutting down and leaving in lead

The Diesel pile hammer may be left in the lead for a temporary shutoff. There are two possibilities to safely support the Diesel pile hammer:

- Let the Diesel pile hammer rest on the material to be driven
- Let the Diesel pile hammer rest on the lower support device



Danger

Use a height safety device to prevent a fall (mandatory at a lead height of above 16 feet (5 meters), see Chapter 7.4 “Installation of safety devices”)!
Danger of a fall!



Warning

Make sure the carrier unit exhibits a sufficient stability! Take into account a change in the weather (rain, storm)! **Danger of overturning!**

Do not touch the Diesel pile hammer shortly after operation! **Danger of burns!** Let hot components cool for a sufficient period!

You must wear a hard hat, safety gloves, safety boots and appropriate work clothes. You must wear a lifesaving vest when working above a water surface!



Block the danger zone of 1.5 times the lead height! Use warning signs to prevent anyone from entering this zone! Observe local regulations for the blocking of job sites!

Proceed as follows:

1. **When resting on the pile:** Drive the pile to at least half the depth (See Chapter 9.1 “Pile driving”)!
2. **When resting on the pile:** Bring the Diesel pile hammer to rest on the pile! You may, for example, turn the fuel supply off during the driving phase and wait until the piston has come to a complete halt (See Chapter 8.7 “Fuel supply control”).
When resting on the support device: Let the Diesel pile hammer rest on the lower support device (See Chapter 7.4 “Installation of the safety devices”)!
3. Let the Diesel pile hammer cool down completely!
4. Install the protection hood, protection rail and exhaust covers (See Chapter 5.1 “Transport safety”)!
5. Take the carrier unit out of operation (See operating instructions for the carrier equipment)!
6. Secure the carrier unit (Activate locking brake, remove ignition key, close doors, windows and hatches, lock doors)!
7. Secure the danger zone of 1.5 times the lead height in accordance with local regulations for the blocking off of job sites!

Removal from the lead

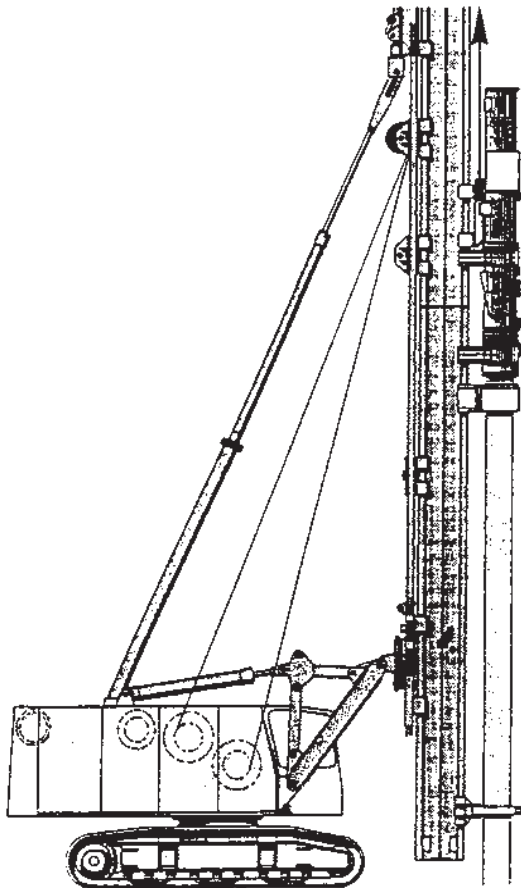

Rest on material to be driven

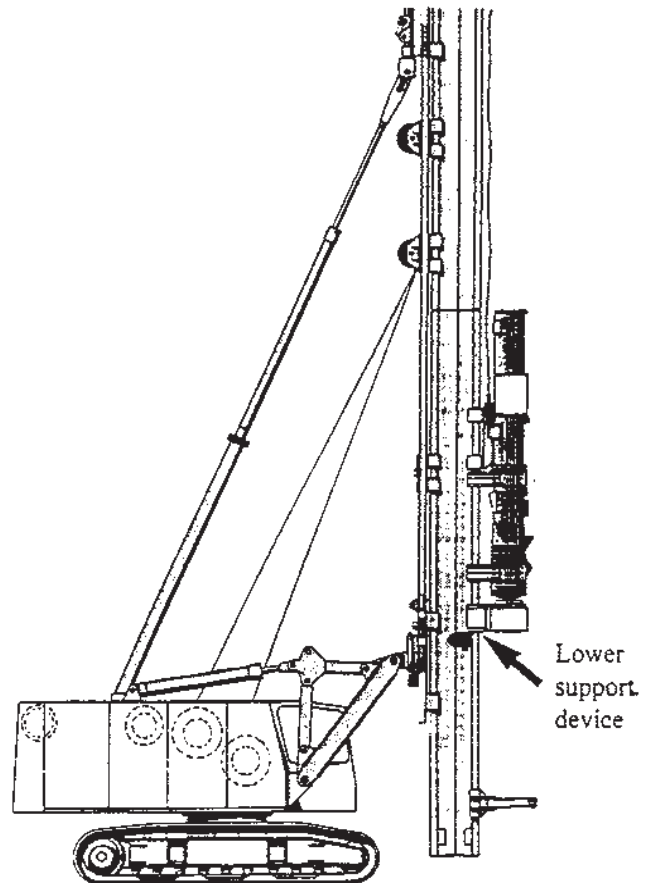

Rest on lower support device

10.2 Removal from the lead

When the Diesel pile hammer will not be operated for several days, it will be necessary to remove it from the lead.



Danger

Use a height safety device to prevent a fall (mandatory at a lead height of above 16 feet (5 meters), see Chapter 7.4 "Installation of safety devices")! Danger of a fall!



Warning

Follow the operating instructions of the carrier equipment! Do not touch the Diesel pile hammer shortly after operation! Danger of burns! Let hot components cool down for a sufficient period!

You must wear a hard hat, safety gloves, safety boots and suitable work clothes. You must wear a lifesaving vest when working above a water surface!



Removal from the lead

Proceed as indicated below:

1. Let the Diesel pile hammer rest on the material to be driven or on the ground!
2. Let the Diesel pile hammer cool down completely!

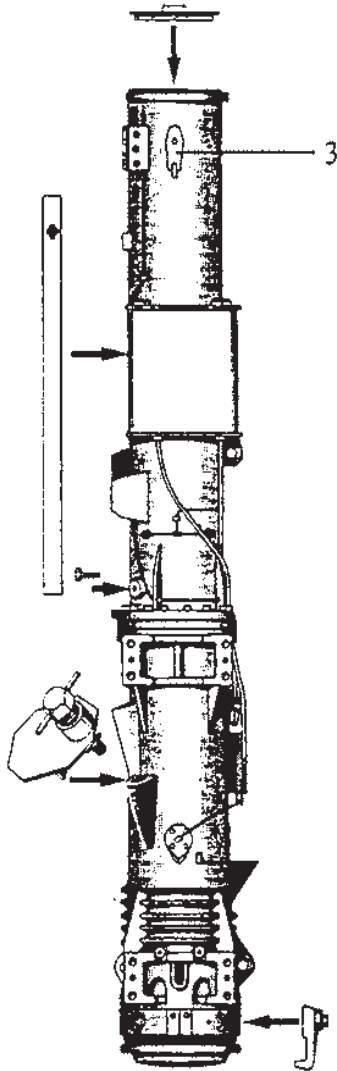

3. Install the piston locking screws, piston safety, protective hood, protection rail and exhaust covers (See Chapter 5.1 "Transport safety")!
4. Remove the ropes from the fuel control pump!
5. Place the steel cable loops around the lifting ears (3) and on the hook of the carrier unit!
6. Lift the Diesel pile hammer approximately 4 inches (10 cm) with the lifting equipment!
7. Remove all four hammer guides of the Diesel pile hammer!
8. Install the transport angles! Then place the Diesel pile hammer horizontally on wooden blocks!
9. Remove the steel cable loops from the lifting plates (3) and from the hook of the carrier unit!
10. Put the carrier equipment out of operation (See operating instructions for the carrier equipment)!
11. Secure the carrier unit (Activate locking brake, remove ignition key, close doors, windows and hatches, lock doors)!
12. Secure the job site in accordance with local regulations for the blocking off of job sites!

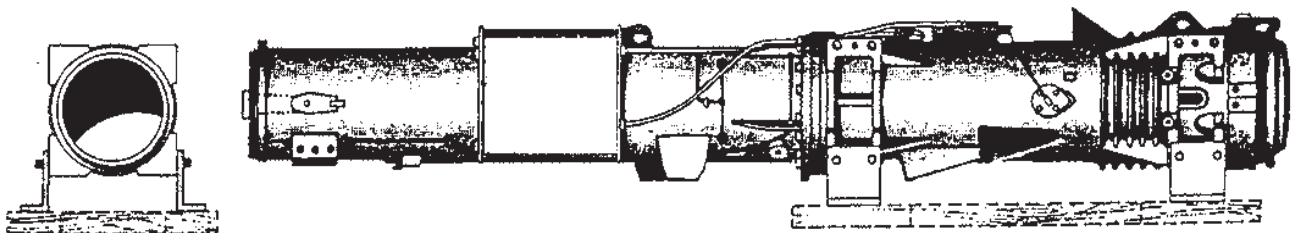

10.3 Storage



Caution

Let the Diesel pile hammer fully cool down prior to storage! Danger of burns and fire!

You must wear safety gloves, safety boots and suitable work clothes. A suitable breathing apparatus must be worn, when required



The following points must be observed when storing the Diesel pile hammer:

1. Check the Diesel pile hammer for damages and wear! Have the necessary repairs carried out immediately! This prevents the work from being forgotten.
2. Check the tanks and lines of the Diesel pile hammer for leaks and a solid fit!
3. When required: Have the impact areas and catch groove machined and replace the damping rings!
4. Drain the tanks (fuel, oil, ether)!



Warning

Fuel, ether and lubricants are extremely flammable and explosive under certain conditions! Drain the tanks only in a well ventilated area!

No smoking or work with open flames or sparks is allowed during the draining of the tanks and in storage areas for fuel, ether and lubricants!

5. Clean the filters!
6. Close the drain openings of the fuel pump with a rubber plug!
7. Remove and clean the piston, impact block, upper and lower cylinder section. Check all connection elements for a solid fit!
8. Clean and check the tripping device as well as the guide components of the Diesel pile hammer and of the tripping device for damage and wear (See Chapter 12.3 "Guides" and Chapter 12.4 "Tripping device")!
9. Clean and check the pile helmet, attachment cables, pile helmet cushion and accessories (bridle, support devices) for damage and wear (See Chapter 12 "Maintenance and troubleshooting")! pile helmet cushions made of wood do not store well and are thus not to be stored for a long time!
10. Check the tool chest and determine its completeness and the condition of the parts! Replace missing or unusable parts with new parts! Check the control cables for the tripping device and fuel control pump for damage and wear (replace, if necessary)!
11. Check the condition and completeness of protection devices and personal safety equipment such as
 - Protective clothing, hard hat, safety gloves and safety boots,

Laying-up

- Safety goggles and ear plugs,
- Lifesaving vest
- Height safety devices

The personal safety equipment must meet local safety regulations!

12. Prepare the Diesel pile hammer for storage (See "Laying-up")!
13. Protect the Diesel pile hammer against the effects of the weather! Cover the Diesel pile hammer and all accessories (Do not use plastic foil or other coated materials)! If possible, store the Diesel pile hammer in an unheated and dry room exhibiting minimal temperature changes! Do not store the Diesel pile hammer in direct sunlight!

Laying-up

The protective effect is very much a function of the thickness and viscosity (ductility) of the material used. We recommend the use of Moly Grease 129; it is a thick grease that you can apply with a rag or brush.

1. Disassemble the Diesel pile hammer! Observe the installation information indicated in Chapter 12 "Servicing and troubleshooting"!
2. Remove all dirt and rust from all components! Replace worn or damaged parts!
3. Touch up the paint! Let the fresh paint dry!
4. Run a corrosion protection oil through the fuel and lubricant pump!

5. Lubricate the tripping device and subsequently apply a rust protection oil to it by brush.
6. Apply a rust protection oil by brush to the guide parts of the Diesel pile hammer and the tripping device!
7. Spray the tank inside with a rust-inhibiting oil! Then solidly close the tanks! Close the fuel tank with accessory screw (ID No. 17184 without ventilation hole)!
8. Apply a rust-inhibiting oil by brush to the impact hood, attachment cables, impact hood cushion and accessories (bridle, support devices)!
9. Carefully apply grease such as Moly Grease 129 by brush to all unpainted parts (including the holes in the end ring, upper and lower cylinder)
10. Assemble the Diesel pile hammer and all transport safety devices! Follow the assembly information in Chapter 12 "Servicing and troubleshooting" as well as Chapter 5.1 "Transport safety devices"!
11. Apply a rust-inhibiting oil to all metal tools in the tool chest!

11. Maintenance



Danger

Maintenance work must be carried out by qualified and authorized experts!

Place the Diesel pile hammer out of operation prior to carrying out any maintenance work! Make sure the unit cannot be put into operation by other persons during maintenance work! Danger to life!

Use a height safety device to prevent a fall (mandatory at a lead height of above 16 feet (5 meters), see Chapter 7.4 "Installation of safety devices")! Danger of a fall!



Warning

Do not touch the Diesel pile hammer after operation! Danger of burns! Let hot components cool down sufficiently!

You must wear a hard hat, safety gloves, safety boots and suitable work clothes. You must wear a lifesaving vest when working above a water surface!



Lubricant)*	Specification	Temperature range	Recommendation)**
EO-20	CD motor oil SAE 20W-20	-10 °C to +15 °C	For a low-smoke combustion
EO-40	CD motor oil SAE 40	+25 °C to +50 °C	MCI (BEL-RAY) EXXON Special 2-T Motor Oil DEA Sprint S2T Texaco Motex 2T
EO-50	CD motor oil SAE 50	-10 °C to +50 °C	
LUB-D	Special lubricant	All year	Almasol 1250 High temp., BEL-RAY (Pileco part No.93551) Molyube 126 EP Grease 2, Molyube 26 HD, Molycote FB 180, TRC Moly high temp., Roco MHT, Texando FO20, Mobilith SHC 460, DEA Spectron FO20, 238 Moly Ultra Supreme (Schaeffer, Pileco, USA) or similar
SP-F	Additional lubricant	All year	BEL-RAY Molyube Friction Modifier (DELMAG Order No.89120)

)* Short designation by the Main Association of the German Building Industry

)** Lubricants were selected especially for DELMAG Diesel pile hammers after extensive tests.

- Applies all the time
- Additional for hard pile-driving work
- Additional for driving batter piles

Maintenance

Maintenance work	Material (See Page 11-1)	Maintenance interval							
		Daily prior to startup	Daily after shutoff	Every 30 minutes	Every hour	Every 2 hours	Once a week	Once a month	When required
<i>Tightening</i> of all screws and bolts on the cylinder end ring and upper cylinder section, fuel control pump, lubricant pump, injection valve cover, guide sleeves and guide strips. See Chapter 12.2 "Screwed/bolted connections"!		●				●			●
<i>Check for wear</i> at guide sleeves for the Diesel pile hammer, guide strips of the tripping device and guides for the pile helmet. See Chapter 12.3		●							
<i>Check for wear</i> at damping rings. See Chapter 12.9		●							
<i>Check for wear</i> at wear strips on the leads. Weld a flat bar as reinforcement, when the thickness of the wear strips is less than 2mm! See Chapter 12.3 "Guides"!		●							
<i>Check the operating mode</i> of the tripping device. See Chapter 12.4 "Tripping device"!		●							●
<i>Lubricate</i> the wear strips on the leads	Multipurpose grease containing MoS ₂	●				●			
<i>Lubricate</i> the impact block and cylinder end ring (generally 5 strokes per grease nipple with a grease gun; 10 strokes for heavy pile-driving work). Impact block must be in place! See Chapter 12.7 "Grease nipple"!	LUB-D	●	●	○	●				
<i>Lubricate</i> the tripping device (5 strokes per grease nipple with a grease gun). See Chapter 12.7 "Grease nipple" and Chapter 12.4 "Tripping device"!	LUB-D						●		
<i>Lubricate</i> the upper cylinder section (10 strokes per grease nipple with a grease gun). See Chapter 12.7 "Grease nipple".	LUB-D for a batter of more than 1:10; add 5% SP-F	○	○		○				
<i>Check</i> the degree of overlapping of the catch between the Diesel pile hammer and the tripping device over the whole lead length. See Chapter 12.4 "Tripping device"!		●							●
<i>Check</i> the reference value for the fuel control pump. See Chapter 12.5 "Pumps"!									●
<i>Check</i> the upper cylinder section for a uniform oil film. See Chapter 12.5 "Pumps"!						●			
<i>Check</i> all cables (Driving cables, pile cables, pile helmet cables, pulling cables for the fuel control pump and tripping device ...) for damage and replace, if required. See Chapter 5.2 (Transport cables"!		●							●
<i>Clean</i> the fuel and lubricant filters. See Chapter 12.6 "Filters"!									●
<i>Clean</i> the combustion chamber. See Chapter 8.8 "Clean the combustion chamber"!		●							●
<i>Clean</i> the Diesel pile hammer and attached components.									●
<i>Disassemble and clean</i> the fuel control and lubricant pumps. See Chapter 12.5 "Pumps"!									●
<i>Replenish</i> the fuel tank. See Chapter 8.4 "Bringing the Diesel pile hammer and the pile helmet into the operating position" for the mixing ratio.	Fuel in accordance with Appendix A3 "Applicable fuels"	●							●
<i>Replenish</i> the lubricant tank (with each filling of the gas tank).	As a function of the temperature; EO-20/40/50	●							●

Servicing and trouble shooting

12. Servicing and troubleshooting



Danger

Maintenance and repair work must be carried out by qualified and authorized experts!

Place the Diesel pile hammer out of operation prior to carrying out any maintenance and repair work! Make sure the unit cannot be put into operation by other persons during maintenance and repair work! Danger to life!

Use a height safety device to prevent a fall (mandatory at a lead height of above 16 feet (5 meters), see Chapter 7.4 "Installation of safety devices")! Danger of a fall!



Warning

Do not touch the Diesel pile hammer after operation! Danger of burns! Let hot components cool down sufficiently!

You must wear a hard hat, safety gloves, safety boots and suitable work clothes. You must wear a lifesaving vest when working above a water surface!



12.1 Troubleshooting

Problem	Possible cause	Symptoms	Fault / Remedy
Diesel pile hammer does not start	Compression too low	Impact block drops quickly when lifting the Diesel pile hammer	Defective or stuck piston rings (Replace as per Chapter 12.10 "Piston and impact block rings").
		Strong blowing effect at impact block	
		After dropping and without a fuel supply, piston does bounce at least three times and then sink slowly	Replace defective or worn parts or have repairs made by a DELMAG-authorized repair shop.
		Grooves in lower cylinder section below exhaust opening	
	Damaged cylinder sleeves	Drop piston several times (cold blows) until there is a sufficient penetration resistance.	
	Low soil resistance		Soft soil, light or pointed or narrow material to be driven, pile runs

Servicing and trouble shooting

Problem	Possible cause	Symptoms	Fault / Remedy
Diesel pile hammer does not start	Oil, grease or water in combustion chamber	Dull sound, when piston impacts the impact block	Clean combustion chamber (See Chapter 8.8 "Clean combustion chamber").
		Black smoke (—> oil and/or grease in the combustion chamber)	
		White smoke (—> water in combustion chamber)	
	Fuel problems	Dull sound, when piston hits the impact block, black smoke (—> too much fuel)	Leaking relief valve (Replace relief valve, clean combustion chamber, see Chapter 8.8 "Clean combustion chamber").
		No smoke or little gray smoke (—> too little fuel)	<p>Air in fuel control pump (Ventilation see Chapter 8.7 "Fuel supply control")</p> <p>Selected setting of fuel control pump is too low (select higher setting, possibly intermediate pumping and activate shutoff valve several times, see Chapter 8.7 "Fuel supply control").</p> <p>Fuel control pump is not working (cleaning and setting as indicated in Chapter 12.5 "Pumps").</p> <p>Clogged ventilation opening at tank screw plug (clean).</p> <p>Defective check valve, suction valve, injection valves or shutoff valve (replace).</p> <p>Damaged or clogged fuel lines (replace or clean).</p> <p>Dirty fuel tank (clean).</p> <p>Dirty fuel filter (clean as indicated in Chapter 12.6 "Filters").</p>
White smoke		Water in fuel (clean fuel tank, fuel filter and fuel lines, clean combustion chamber, see Chapter 8.8 "Clean combustion chamber").	

Servicing and trouble shooting

Problem	Possible cause	Symptoms	Fault / Remedy
Diesel pile hammer runs irregularly (See "Diesel pile hammer does not start")	Fuel problems	Black smoke (→ too much fuel)	Defective check valve, suction valve or shutoff valve at fuel control pump (replace defective valve, see Chapter 12.5 "Pumps", clean combustion chamber, see Chapter 8.8 "Clean combustion chamber").
		Only little gray smoke (→ too little fuel)	Pump element installed in reverse position, supply opening must be at the top (install in correct position, see Chapter 12.5 "pumps"). Sticking pump element, pump lever or guide sleeve or the setting value at the pump lever has been changed (See Chapter 12.5 "Pumps"). Defective pressure unit in fuel control pump (Replace as indicated in Chapter 12.5 "Pumps"). Damaged or clogged injection valves or fuel lines (replace or clean). Clogged ventilation hole at tank screw plug (clean). Dirty fuel filter (clean as indicated in Chapter 12.6 "Filter").
		White or black smoke (→ water or dirt in fuel)	Water in fuel (clean fuel tank, fuel filter and fuel lines, clean combustion chamber as indicated in Chapter 8.8 "Clean combustion chamber") Dirty fuel tank (clean)
	Lack of lubrication	Impact block gets stuck in cylinder or end ring	Too little or incorrect lubricant (use lubricant and maintain lubrication intervals as indicated in Chapter 11 "Maintenance").
	Mechanical	Damage to impact areas damage of piston or impact block	Machine impact areas
Stuck or broken piston rings		Replace defective piston rings (See Chapter 12.10 "Piston and impact block rings").	

Servicing and trouble shooting

Problem	Possible cause	Symptoms	Fault / Remedy
Diesel pile hammer runs irregularly	Mechanical damage	Damaged or deformed upper cylinder section	Replace defective or worn parts or have a DELMAG-authorized repair shop carry out the necessary repair work.
		Worn cylinder or piston (not round)	
	Changing soil conditions	Material to be driven penetrates at different rates	Make adjustments during the pile-driving by regulating the fuel control pump (See Chapter 8.7 "Fuel supply control").
Tripping device does not lift the piston	Piston is not latched	Broken tension sleeves at latch lever	Replace defective or worn parts (See Chapter 12.4 "Tripping device").
		Bent latch lever	
		Damaged bearing, bolts or straps at tripping device or bent clamping pins	
	Piston is not carried along	Rounded edges at piston lifting groove or at latch	
		Bent or broken flat spring at tripping device	
		Loose flat spring screws	
	Worn guide strips or guide sleeves	Immediately replace worn guide parts (See Chapter 12.3 "Guides"! Repair lead!).	
Tripping device does not lift the Diesel pile hammer	Cam of the tripping device does not grasp below the latches at the Diesel pile hammer	Lack of lubrication at the latch of the tripping device	Lubricate (Lubricant and lubrication intervals as indicated in Chapter 11 "Maintenance").
		Broken torsion spring at the latch of the tripping device	Replacement (See Chapter 12.4 "Tripping device").

Screwed/bolted connections

12.2 Screwed/bolted connections

Tighten all screwed or bolted connections again daily prior to the pile-driving work and then after every two hours of operation at the

- (1) Upper cylinder extension
- (2) Upper cylinder
- (10) Lubrication pump
- (12) Fuel control pump
- (13) Injection valve cover
- (17) Cylinder end ring
- (22) Hammer guides
- (A1) Guide gibs

Maintain the torque values indicated in the table below.



Immediately replace overtightened screws with new ones of the same strength! The Diesel pile hammer cannot be operated safely with loose or overtightened screws!

Follow the safety instructions indicated at the beginning of Chapter 12 "Servicing and troubleshooting"!

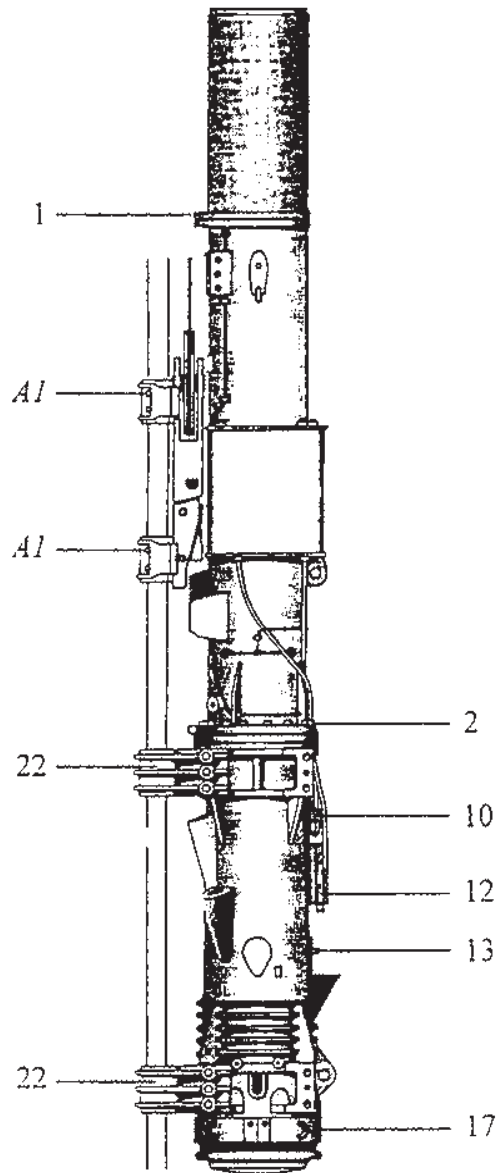

Bolt torque values

Pos. No.	Description	Type					
		D5 to D8	D12 to D19	D25 to D30	D36 to D46	D62	D80 and D100
1	Upper cylinder extension	553 ft.lbs				1106 ft.lbs	
2	Upper cylinder						
10	Lubrication pump	206 ft.lbs					
12	Fuel control pump						
13	Injection valve cover						
17	Cylinder end ring					1106 ft.lbs	
22	Hammer guides	553 ft.lbs				737 ft.lbs	1106 ft.lbs
A1	Guide gibs	369 ft.lbs	428 ft.lbs	553 ft.lbs	295 ft.lbs		

Guiding devices

12.3 Guides

Prior to the driving of piles, it will be necessary to check the wear of the

- Guide sleeves of the Diesel pile hammer
- Guide strips of the tripping device
- Guides of the pile helmet
- Wear strips along the whole lead length!

Prior to the driving of piles, the wear strips must be lubricated daily with a MoS₂-containing multi-purpose grease along the whole lead length!



Worn guide parts must be replaced immediately! Wear strips at the lead that are too thin must be reinforced immediately! If this is not done, the Diesel pile hammer, impact block or tripping device may jump out of the guides! Danger of crash!

Use only DELMAG spare parts! We cannot guarantee the safe operation of the Diesel pile hammer when other spare parts are used!

Follow the safety instructions indicated at the beginning of Chapter 12 "Servicing and troubleshooting"!

The play for the guide sleeves and guide strips shall not exceed 1/4" or 9/32" (6 mm or 7 mm) (See illustration on right). When it exceeds the above values, the guide sleeves and guide strips must be replaced immediately!

The wear strips must have a minimum thickness of 5/64" (2 mm) along the whole lead length (See illustration on left). When they are thinner, the guide strips must be "reinforced" by welding flat bars to them!

Lead form

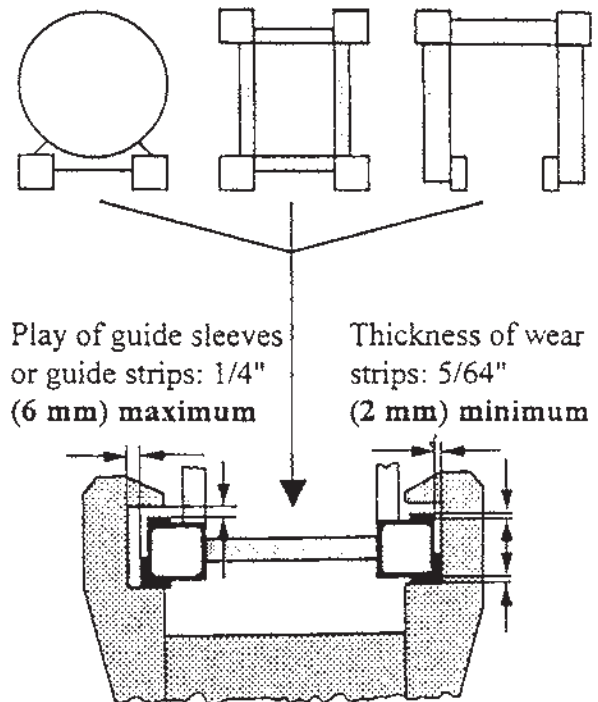

Lead form

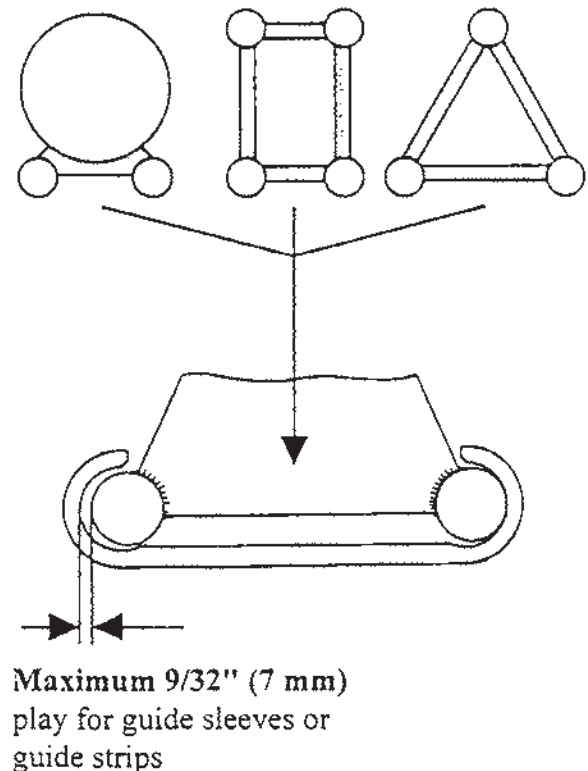

Tripping device

12.4 Tripping device

The following items must be checked daily prior to the driving of the piles and when problems are suspected:

- The proper functioning of the latch and the tripping mechanism of the tripping device
- The degree of overlapping between the Diesel pile hammer and tripping device along the whole lead length
- The play in the guides of the tripping device

Lubricate the tripping device weekly with LUB D (5 strokes with a grease gun per grease nipple)!



Danger

Do not operate the Diesel pile hammer, when the tripping device does not function properly or the overlapping distance between the Diesel pile hammer and the tripping device is too short! Danger of crash!

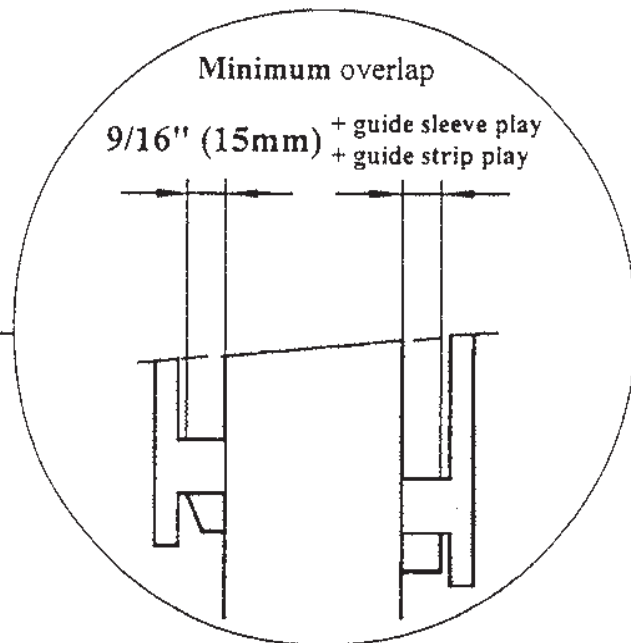
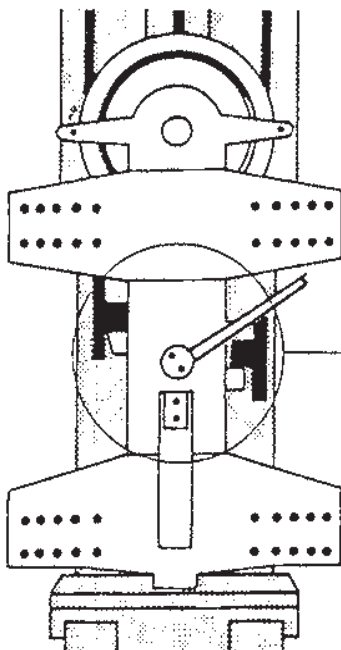

Warning

Worn guide strips must be replaced immediately! When this is not done, the tripping device may jump out of the guide! Danger of crash!

Use only DELMAG spare parts! We cannot guarantee a proper functioning of the tripping device when other spare parts are used!

Follow the safety instructions indicated at the beginning of Chapter 12 "Servicing and troubleshooting"!

Along the whole lead length, the overlap of the latches between the Diesel pile hammer and the tripping device must be at least 9/16" (15 mm) greater than the play of the guide strips (See Chapter 12.3 "Guides")!

The play of the guide strips must be less than 1/4" or 9/32" (6 mm or 7 mm) (See Chapter 12.3 "Guides"). If this is not the case, the guide strips must be replaced immediately!

Operational test

Testing the proper operation

The tripping device is considered inoperative, when one of the following criteria is not met:

1. Lower the tripping device (See Chapter 8.6 "Tripping device")!
2. Make sure the trip cam lever (A5) is pushed up when the tripping device impacts the lower support device (9)! At the same time, pawl (A4) must swing out fully and must lock!
3. Check the tension and the screw connection of the flat spring!
4. Pull down on the cable at lever (A2)! The driving pin (A3) must fully reach its end position!
5. Release the cable at lever (A2)! The driving pin (A3) must swing out fully (horizontal position)!
6. Check the proper functioning of the guide pulleys!
7. Check the tripping device for wear! Particularly the pawl (A4) with straps and bolts as well as the driving pin (A3) should not be rounded or exhibit visible wear!

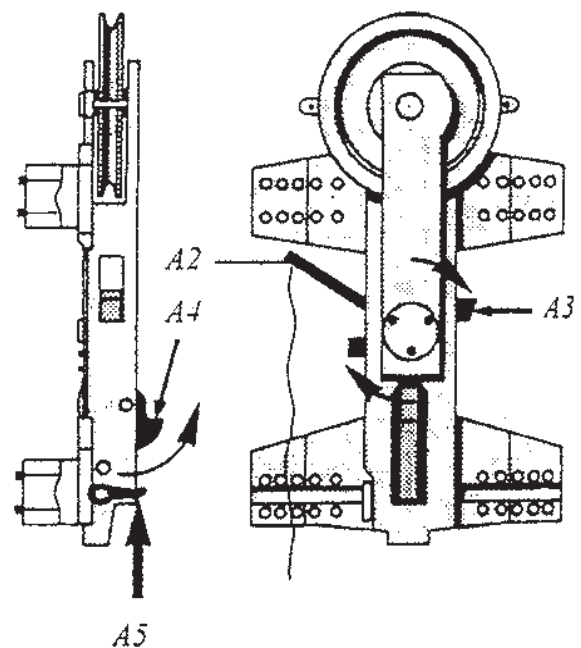
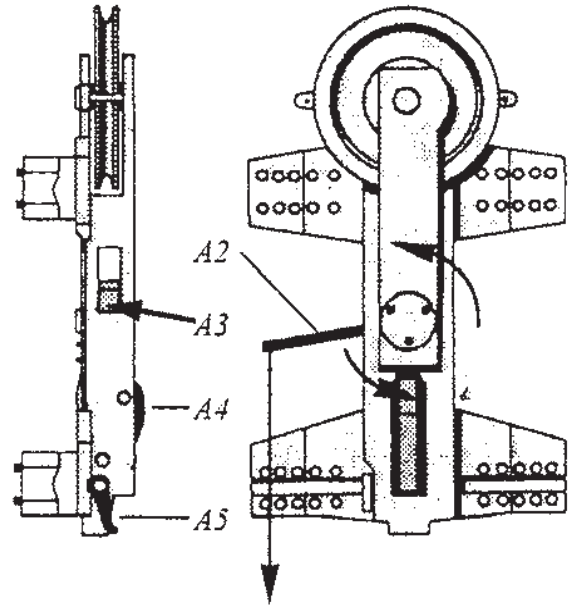

Pumps - Disassembly and cleaning of pumps

12.5 Pumps



Warning

Problems with the fuel or lubricant system must be remedied immediately! Such problems pose an increased fire risk and may cause the destruction of the Diesel pile hammer!

Use only DELMAG spare parts! We cannot guarantee a proper functioning of the tripping device when other spare parts are used!

Follow the safety instructions indicated at the beginning of Chapter 12 "Servicing and troubleshooting"!

Disassembly and cleaning of pumps

The fuel control pump and lubrication pump shall be disassembled and cleaned when necessary (See spare parts list)! Remove all paraffin and dirt residues! Make sure all moving parts move easily! Replace worn and defective parts! The following steps are needed to install the sealing surfaces:

1. Carefully remove any grease from the sealing surfaces as well as from the support surface between the fuel control pump and the upper cylinder section! Use a suitable grease remover! Let the grease remover evaporate fully.
2. Brush "Hylomar SQ32H" (See table for properties) evenly on the sealing surfaces, leaving no bubbles! One tube of "Hylomar SQ32H" is contained in the tool chest.
3. Let the sealing dry for approximately 10 to 15 minutes!

4. Install the sealing surfaces!
5. Check for leaks!

The sealing surfaces can be separated and joined without applying a new sealing mass up to three times. No foreign material should be left on the sealing mass!

Properties of Hylomar SQ32H	
Base	Polyester/urethane mixture
Flash point	No flash point
Storage period	Indefinitely
Temperature resistance	-50 °C to 300 °C
Application quantity	approx. 12 mg/cm ²

Lubricant pump

After each 30 minutes of pile-driving work, check that the upper cylinder section is properly supplied with the lubricant! The upper cylinder section must be covered with a uniform thin lubricant film! The following should be checked as well:

- Is the lubricant tank empty?
- Are the lubricant lines clogged or defective?
- Is the pump lever worn?
- Is the lubricant pump contaminated or defective?

Operate the Diesel pile hammer only after the problems have been remedied!

Use a motor oil for the appropriate temperature range (See Chapter 11 "Maintenance")!

Fuel control pump

Fuel control pump

The control dimension at the fuel control pump is significant for the fuel quantity supplied with each stroke. A dimension that is too long causes an excessive fuel supply to the Diesel pile hammer. Accordingly, there is the risk of the piston jumping into the catch groove. When the control dimension is too small (e.g., due to wear at the pump lever or guide sleeve), the fuel supply will be too low. The Diesel pile hammer is thus unable to reach the maximum blow energy.

Check the control dimension of the fuel control pump as required. Reset the control dimension when it deviates from the nominal dimension!

1. Set the fuel control pump to setting "4" (full load)! To do so, jerk on the right control ropes often as required!
2. Measure the control dimension (See illustration).
3. Compare the measured control dimension with the nominal dimension (See table below)!

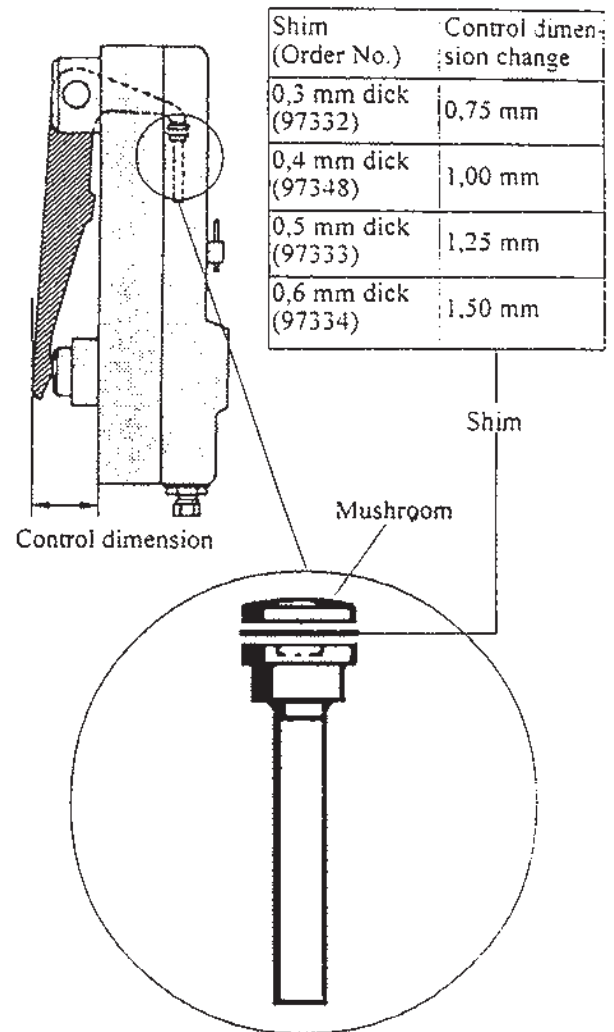

Type	Control dimension (mm)	Supply quantity at full load (cm ³ /stroke)	Fuel control pump Order No.	Injection valve		Pump element			
				Number	Order No.	Diam. (mm)	Order No.		
D5-43	54,0 ^{-0,3}	0,96	130977	16	127950	10	130967		
D6-32	53,5 ^{-0,3}	1,60	122499			13	124300		
D8-22		1,75	41865			14	22903		
D12-32		2,10	122469			15	122470		
D16-32	53,5 ^{-0,3}	2,40	104675			16	44015		
D19-42	54,6 ^{-0,1}	3,54	105758			19	44027		
D25-32/33	54,5 ^{-0,3}	3,90	108780			20	66522		
D30-32/33		4,70	105172			22	65528		
D36-32/33	54,0 ^{-0,3}	5,65	105731			2	63841	24	64804
D46-32/33	54,5 ^{-0,3}	7,15	105202					27	64813
D62-22	53,5 ^{-0,3}	8,70	100259	2	104675	31	67218		
D80-23	55,0 ^{-0,3}	10,50	66948	4		32	67207		
D100-13		12,50	103964			35	14655		

Filter

4. The control dimension must be reset, when the measured control dimension is not within the tolerance. This is achieved by changing the number and thickness of the shims between the pressure section and the mushroom! It is generally sufficient to remove one shim or to use a thinner shim. The pump lever is worn, when it is no longer possible to remove shims. In that case, replace the pump lever and reset the control dimension!
5. Check the injection valve! The pistons in the injection valves must move smoothly and close well. Replace the injection valves when this is not the case!



Caution

Never grind the pressure section or mushroom!

The supplied fuel quantity can be measured directly with the DELMAG test unit for fuel control pumps (Special accessory; Order No. 63417) (See Appendix A2 "Accessories").

12.6 Filter



Warning

Follow the safety instructions indicated at the beginning of Chapter 12 "Servicing and troubleshooting"!

When required, clean the filter of the fuel and lubricant tanks as described below:

1. Drain the fuel tank!
2. Pull the fuel line from the filter nozzle!
3. Unscrew the filter nozzle!

4. Clean the filter insert!
5. Screw the filter nozzle back in!
6. Push the fuel line again on the filter nozzle!
7. Fill the fuel tank!
8. Check the filter nozzle for leaks!
9. Clean the filter of the lubricant tank in the same manner!

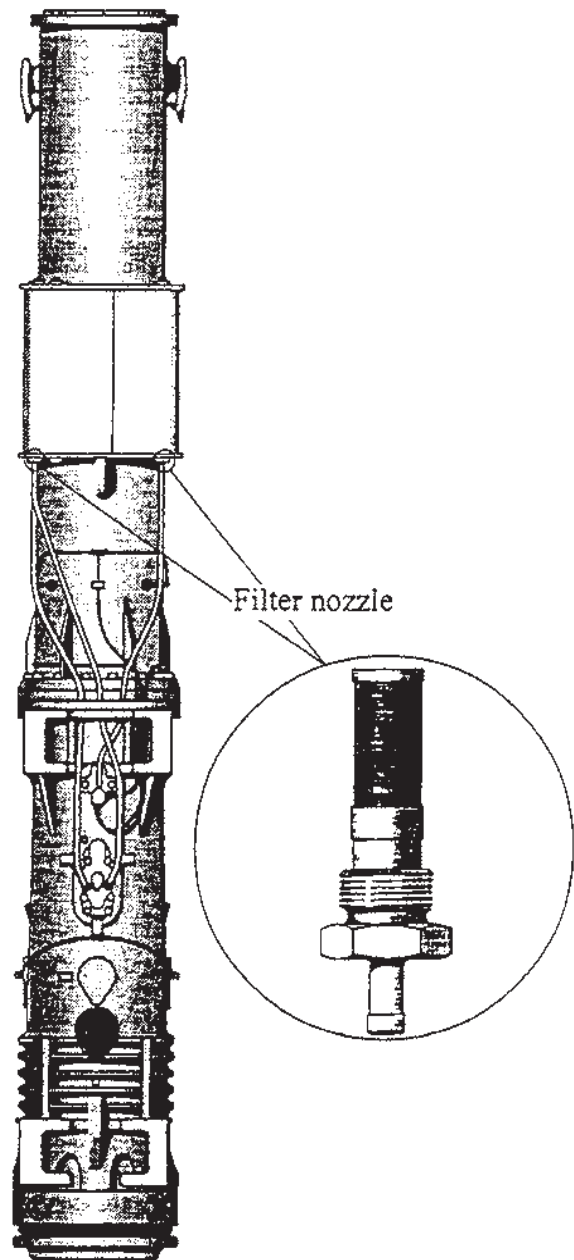

Grease nipple

12.7 Grease nipple



Caution

Be careful when working on a hot Diesel pile hammer! Do not touch hot components! Danger of burns!



The grease nipples and lubrication openings must be free of dirt and carbonization and must allow a free flow for the lubricant. Clogged grease nipples must be replaced!

Pump fresh grease again in the grease nipples of the impact head, cylinder end ring and upper cylinder section after shutting off the Diesel pile hammer! This prevents a carbonization of the grease located in the hot grease nipple!

12.8 Catch groove and piston catch ring

The material to be driven penetrates slowly in particularly solid soil or in the case of a very blunt pile. In such a case, the drop height of the impact hammer may continue to increase. You must, in a timely manner, reduce the fuel supply to prevent the piston catch ring from bouncing into the catch groove of the upper cylinder section (See Chapter 8.7 "Fuel supply control")!

The operation of the Diesel pile hammer must be discontinued immediately, when the piston catch ring has bounced into the catch groove of the upper cylinder section! Check the catch groove and the piston catch ring! Both must always be in perfect condition. Machine a damaged catch groove! Replace damaged piston catch rings!



Warning

The Diesel pile hammer must not be operated with a damaged catch groove!

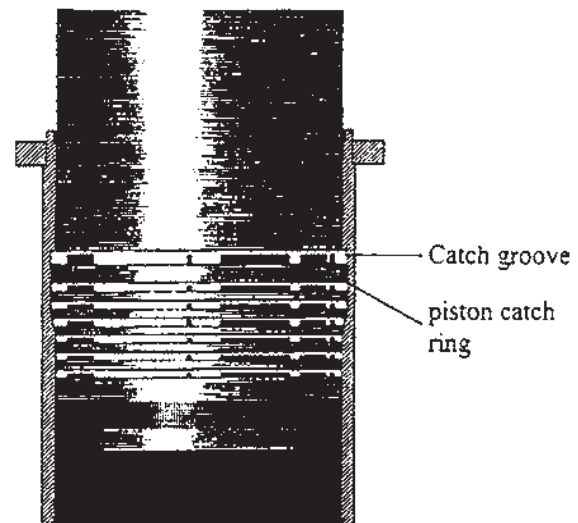

D5 through D12

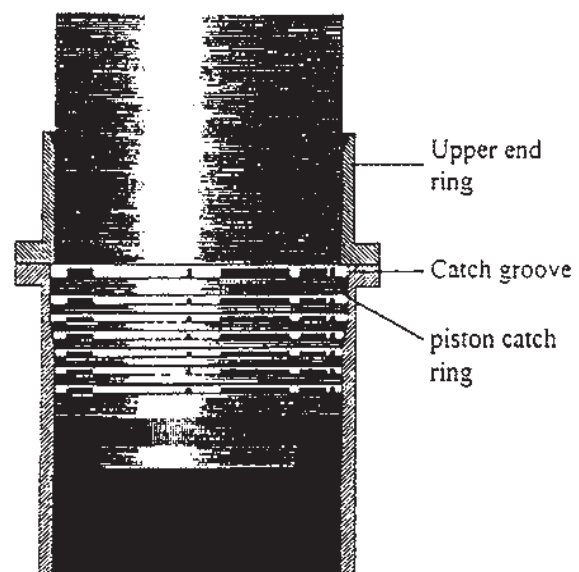

D16 through D100

Damping rings

12.9 Damping rings

Damping rings are components subject to wear. The service life of damping rings (operating hours to wear) can vary tremendously. The service life of the damping rings is a function of

- the type of pile-driving work,
- the number of strokes per minute,
- the quality of the maintenance work,
- outside effects (weather, dirt ...)

Worn or damaged damping rings shall be replaced as described below:



Follow the safety instructions indicated at the beginning of Chapter 12 “Servicing and troubleshooting”!

1. Let the Diesel pile hammer rest on the impact block (19)!
2. Remove the impact block safety device, if present!
3. Lift the Diesel pile hammer until the impact block (19) is fully extended! **Secure the Diesel pile hammer against a falling down (See Chapter 7.4 “Installation of the safety devices”)!**
4. Using a screwdriver, push the two-piece outer damping ring (18) out of the groove! Keep the loose metal guard for the later installation! Work steps 5 through 19 can be ignored, when it is necessary to replace only the two-piece outer damping ring (18).
5. Secure the impact block (19) with wedges against a tilting toward the pile helmet!

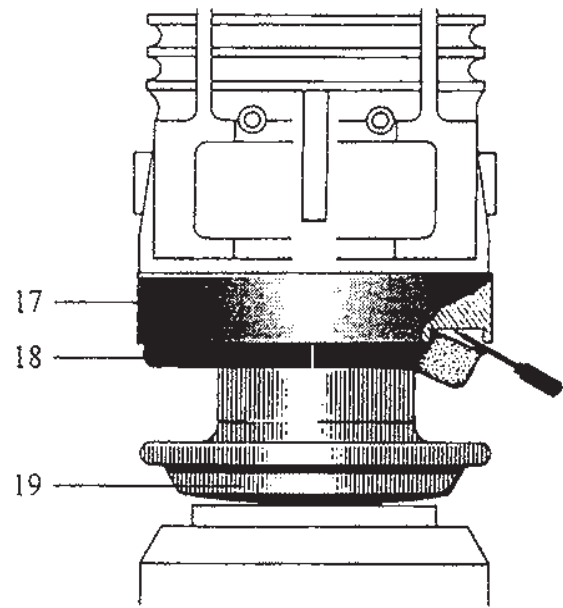

6. Attach the supplied installation plates to the two-piece cylinder end ring (17)!
7. Screw the installation bolts in the lower cylinder section (15)!
8. Unscrew all expansion screws of the cylinder end ring (17)! Keep the expansion screws at a safe place!

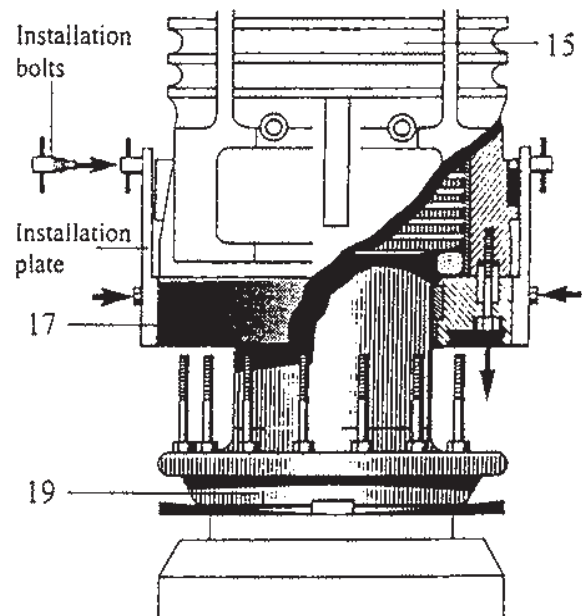

9. Remove the cylinder end ring (17)! To do so, screw four expansion screws in the re-

Damping rings

spective threads (See illustration)! The width is restricted by the installation bolts.

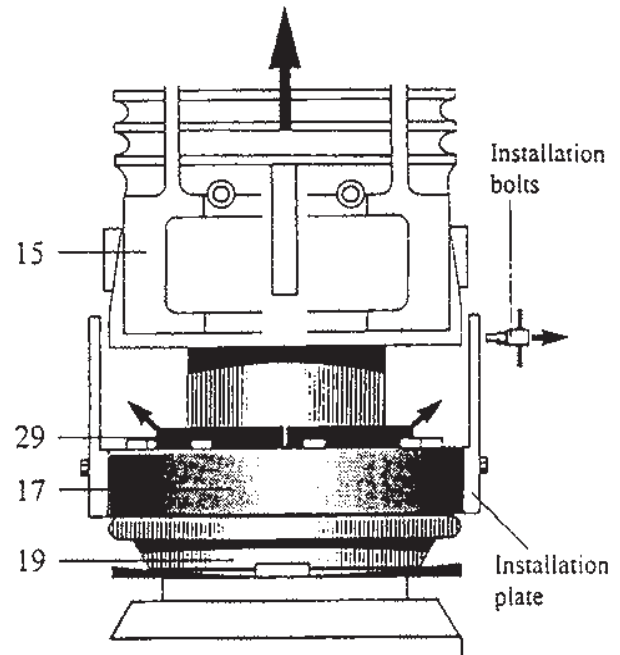
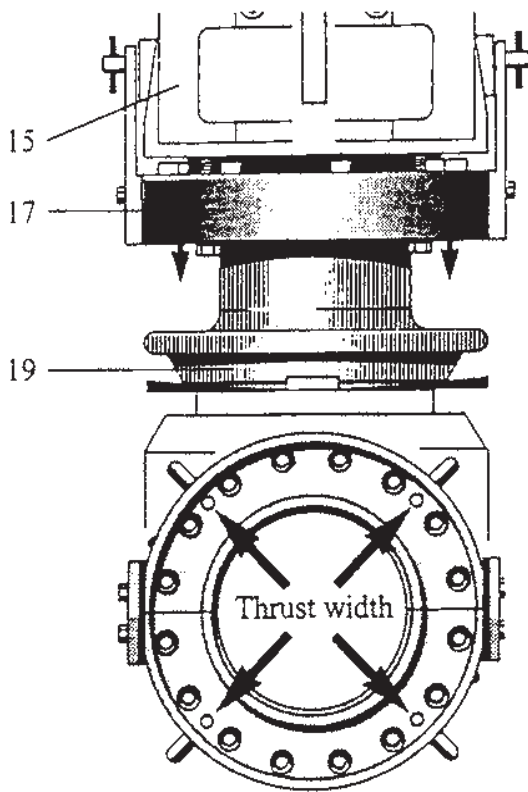

The piston rings remain in the cylinder!
Secure the Diesel pile hammer against a falling down (See Chapter 7.4 “Installation of the safety devices”)!

10. Let the Diesel pile hammer rest on the impact block flange!
11. Unscrew the installation bolts from the lower cylinder section (15)!
12. Pull the Diesel pile hammer upward until the inner damping ring (29) is easy to replace!
Secure the Diesel pile hammer against a falling down (See Chapter 7.4 “Installation of the safety devices”)!
13. Replace the inner damping ring (29)!
14. Let the Diesel pile hammer rest on the impact block flange (15)!
15. Screw the installation bolts in the lower cylinder section (15)!
16. Lift the Diesel pile hammer until the impact block (19) is fully extended!

17. Remove the four thrust screws!
18. Screw all expansion screws back in the cylinder end ring (17)! Follow the torque data (See Chapter 12.2 “Screwed/bolted connections”)!
19. Remove the installation plates!

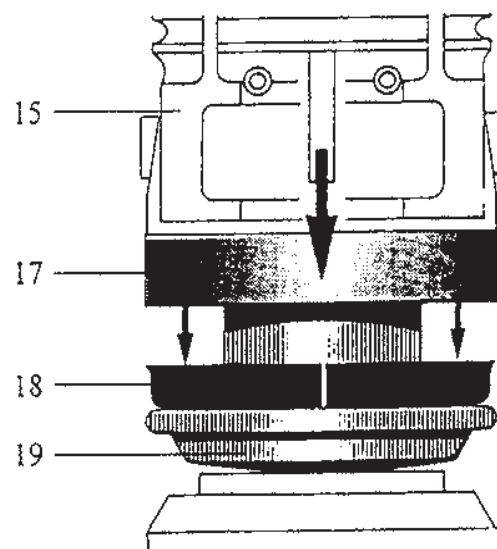

Piston and impact block rings

20. Place a new two-piece outer damping ring (18) on the impact block flange!
21. Place the metal guards indicated in work step 4 on the two-piece outer damping ring (18)!
22. Lower the Diesel pile hammer! With its self-weight, the Diesel pile hammer presses the two-piece outer damping ring (18) into the groove.

12.10 Piston and impact block rings

Worn or damaged piston or impact block rings must be replaced as indicated below:



Follow the safety instructions indicated at the beginning of Chapter 12 "Servicing and troubleshooting"!

With Diesel pile hammers of the types D16 through D46, it will be possible to pull the piston upward and out after disassembling the upper end ring. Work steps 18. and 23. Change accordingly!

1. through 11.
Execute the work steps as indicated in Chapter 12.9 "Damping rings"!
12. Lift the Diesel pile hammer approximately 3 feet (1 meter)! The cylinder end ring (17) is kept together with the installation plates and remains on the impact head flange.
Secure the Diesel pile hammer against a falling down (See Chapter 7.4 "Installation of the safety devices")!

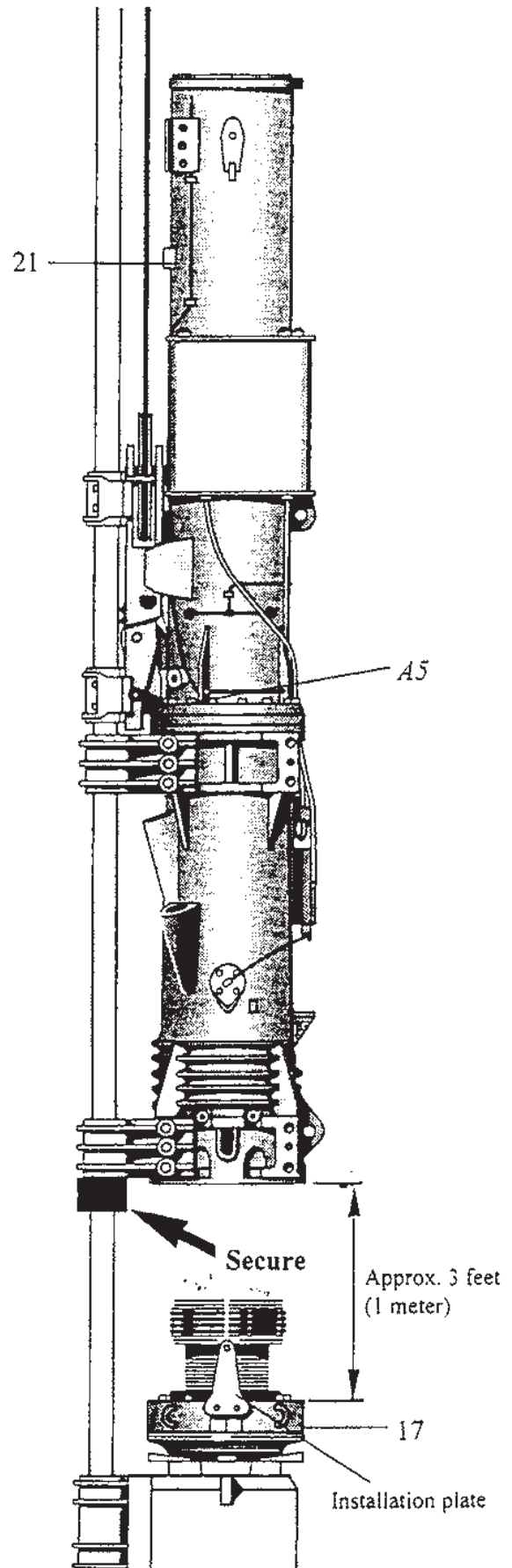

Piston and impact block rings

13. Pull the piston (26) upward with the help of the tripping device and stop just prior to reaching the upper stop (21) (See Chapter 8.6 "Tripping device")!



The catch lever (A5) must not touch the upper stop (21)! This may cause a release of the piston (26) and it may thus come crashing down! Danger of an accident!

14. Screw the supplied ring screw into the piston (26)!
15. Attach a suitable steel cable to the ring screw and the lifting equipment!
16. Lift the piston approximately 2 inches (5 cm)!
17. Push the catch lever (A5) down by hand!
18. Lower the piston until all piston rings are easily accessible!
19. Remove the piston and impact block rings using special piston ring installation pliers (included with the tool chest)!
20. Carefully clean the piston and impact block ring grooves and apply the special grease LUB-D (See Chapter 11 "Maintenance")!
21. Install the new piston and impact block rings using the special piston ring installation pliers (included with the tool chest)!
22. Place the supplied piston ring installation strap around the piston rings!
23. Carefully pull the piston upward until you are able to push the catch (A4) into the groove of the piston (26) by pressing the catch lever (A5) upward by hand.

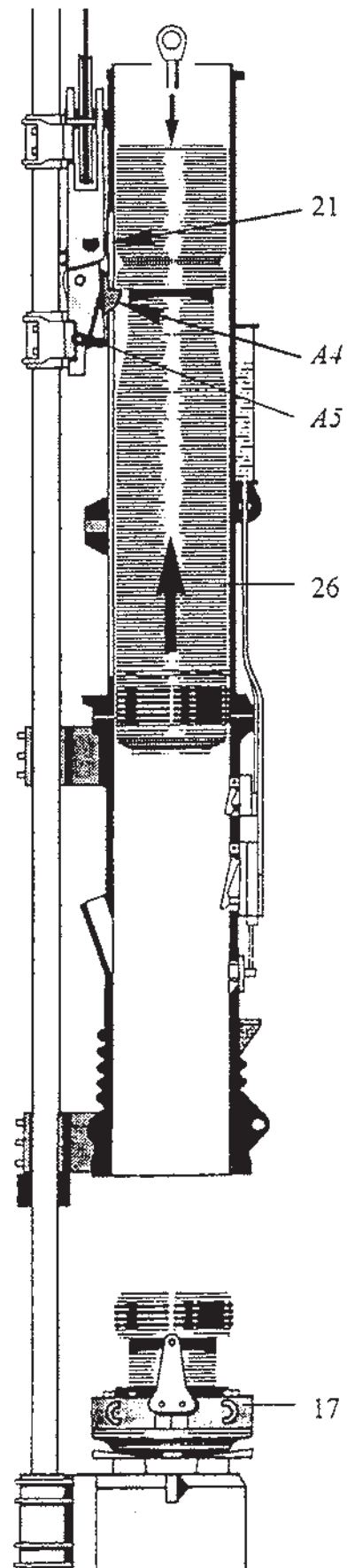

Piston and impact block rings

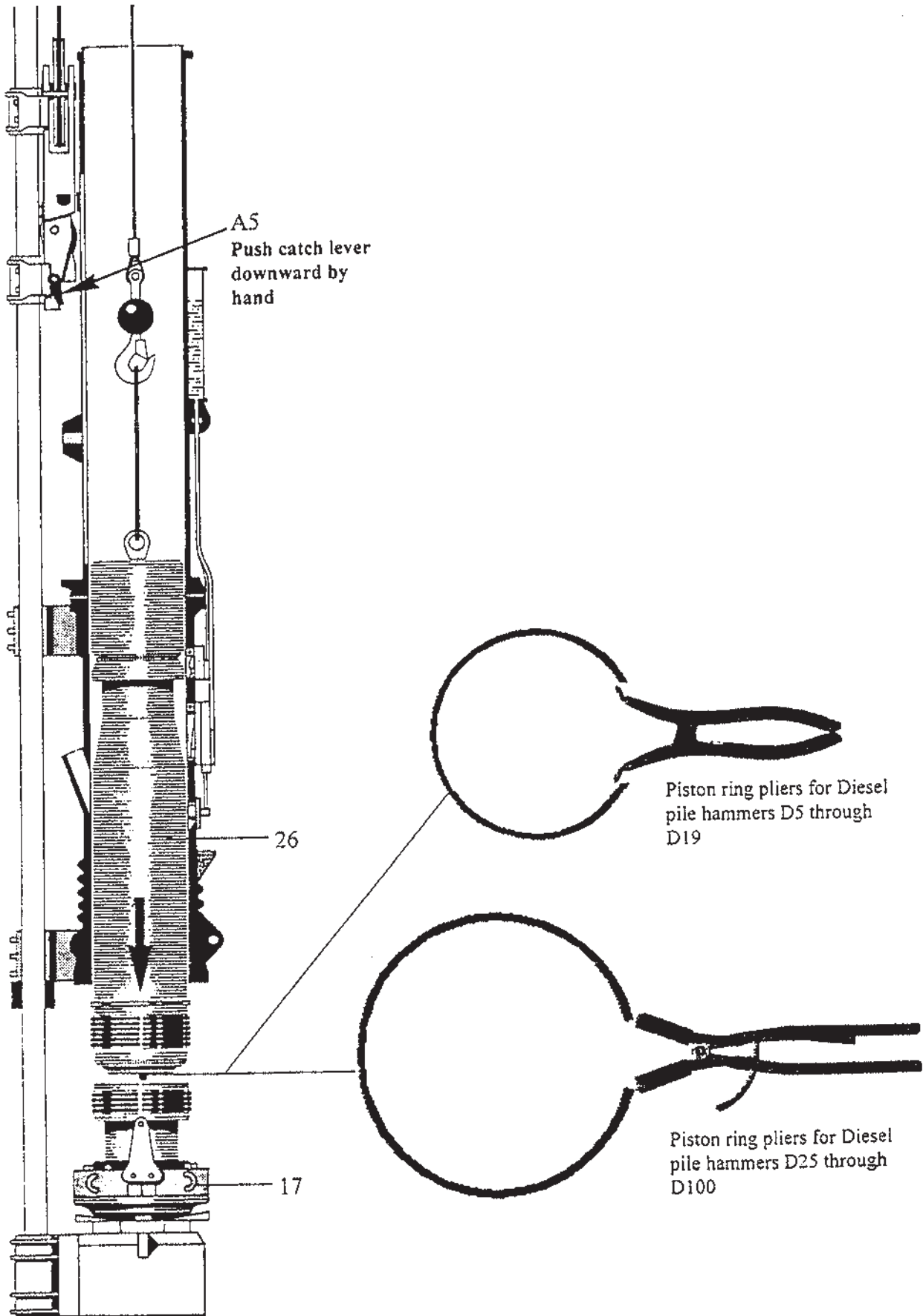

Piston and impact block rings

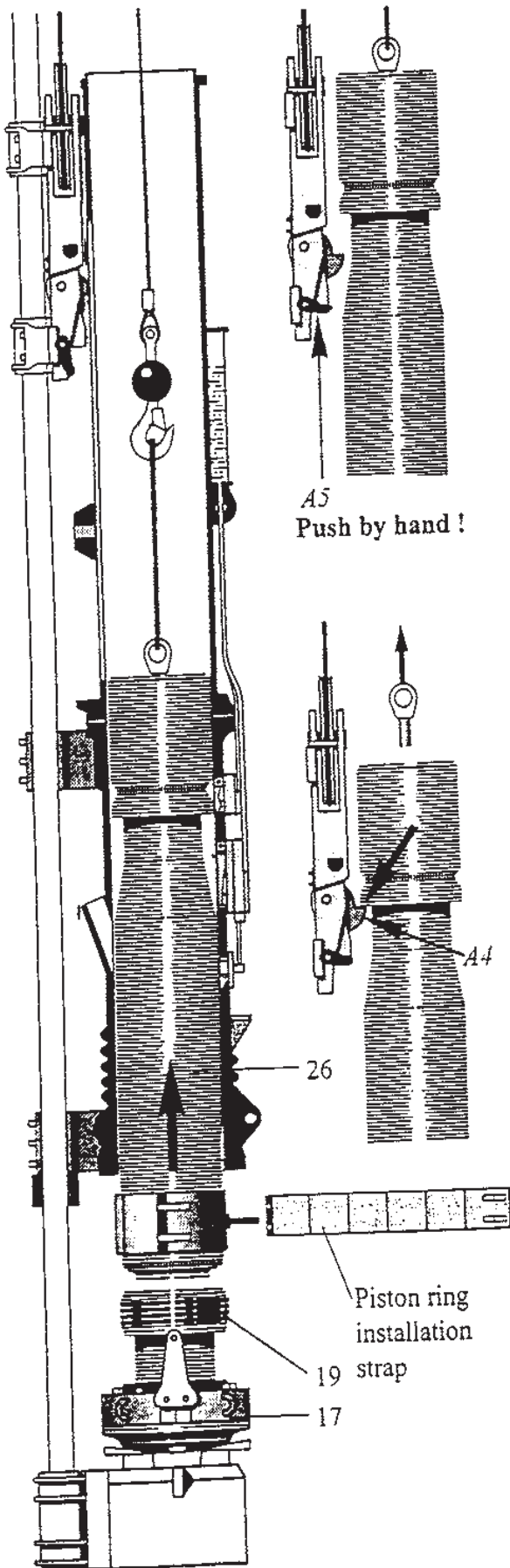

Make sure the piston ring installation strap does not get stuck, when the piston (26) is lifted into the cylinder!

24. Let the piston (26) rest on the catch (A4)!
25. Remove the cable and ring screw from the piston (26)!
26. Lower the piston (26) to the lower stop using the tripping device (See Chapter 8.6 "Tripping device")!

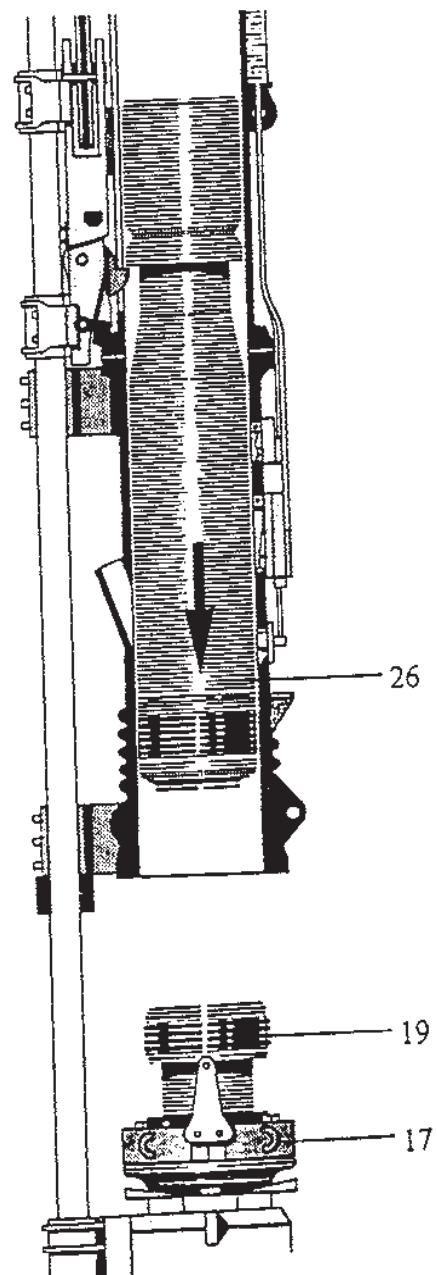

Piston and impact block rings

27. Place the piston ring installation strap around the impact block (19)!
28. Slightly raise the Diesel pile hammer to unlatch the tripping device! Then lower the Diesel pile hammer! Guide the impact block (19) during said phase! Make sure the piston installation strap is not compressed on the cylinder end ring (17) (Stop the downward movement at the appropriate time)!
29. Remove the piston ring installation strap!
30. Install the inner and outer damping rings (See Chapter 12.9 "Damping rings", work steps 13. through 22.)!



Warning

The Diesel pile hammers of the types D16 through D46 may be operated only with the upper end ring or the extension of the upper cylinder section in place! Danger of an accident!

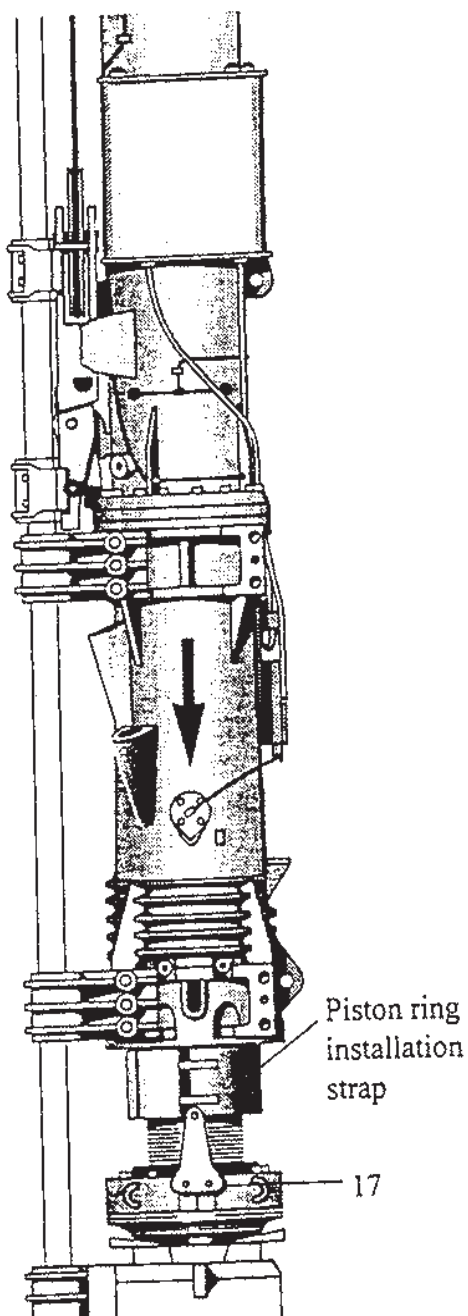

12.11 Compression

Starting difficulties may be caused by a compression that is too low. A major decrease in the compression during the pile-driving work will cause the piston to reach lower and lower heights. The Diesel pile hammer will stop in the extreme case.

The compression can be checked as described below:



You must wear a hard hat, ear plugs, safety goggles, safety gloves, safety boots and suitable work clothes!



1. Place the Diesel pile hammer on a hard pile or a test stand!
2. Set the fuel control pump to setting "0"! To do so, jerk the left control rope as often as required (See Chapter 8.7 "Fuel supply control")!
3. Pull the piston upward until it trips (See Chapter 8.6 "Tripping device")!
4. Watch the piston! Compression is sufficient when the piston bounces after impacting the impact head and comes to rest after at least another three upward and downward movements.

Causes for a compression that is too low:

- Defective or stuck piston rings;
- Insufficient lubrication of impact block or piston;
- Grooves in the lower cylinder section below the exhaust openings;
- Damaged cylinder bushings;
- Inside diameter of the lower cylinder section is not round;
- The pile "runs" (soft soil; light, pointed and narrow material to be driven).

Replace the defective components (See Chapter 12 "Servicing and troubleshooting")! Lubricate the impact block and piston in accordance with the maintenance schedule (See Chapter 11 "Maintenance")!

The following steps are helpful in case of a "running" pile:

Starting difficulties: Let the piston drop several times with the fuel supply shutoff (Setting "0") (cold blows) until the penetration resistance is sufficient for the starting.

Steel cables

12.12 Steel cables

Follow the instructions of Chapter 5.2 “Transport cables”!

Visually inspect the steel cables in accordance with DIN 15020, Page 2, prior to each use. This prevents accidental breaks. Check the cables for possible damage (See Chapter 5.2 “Transport cables”) and for corrosive effects!

Placing and coiling

Avoid sharp edges and kinks! Watch for shifts in the individual strands! This applies in particular to non-twisting steel cables!

Make sure no loops are formed when rolling off the cable! Breakouts are formed when loops are pulled together! Such a cable cannot be used. For that reason, the cable should never be pulled laterally from the reel or spool; coil or roll it off (see illustration)!

Cable care

Steel cables must be stored in a dry area that is free of sand and soil! This prevents corrosion and friction wear. Clean the steel cables and all parts, with which they come into contact (cable drums etc.)!

Regularly apply grease to the steel cables!

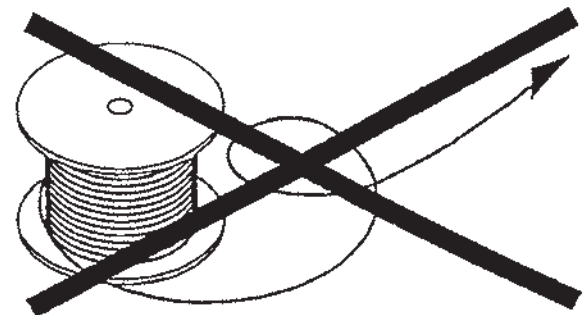
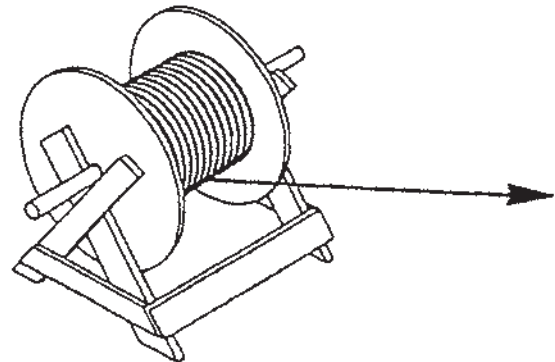
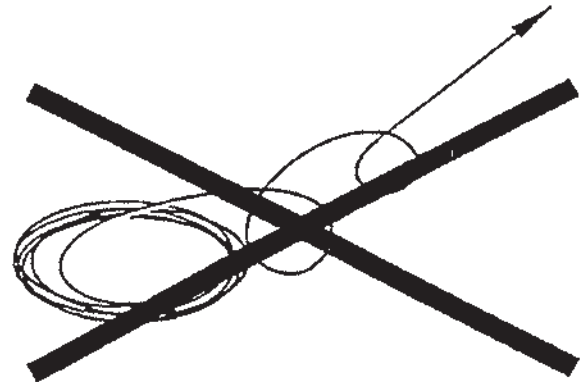
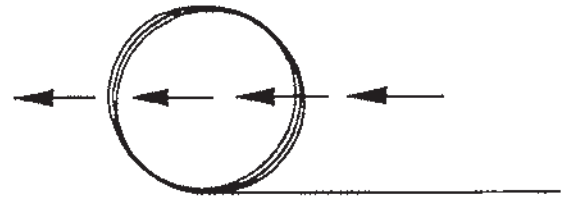

Other starting device for the Diesel pile hammers

A2 Accessories

A2.1 ● Other starting device for the Diesel pile hammers



Read and observe the operating instructions “Diesel Pile hammers” as well as all safety instructions contained in them!

Ether must be handled carefully! Take appropriate measures to prevent a spilling, igniting, inhaling and swallowing as well as contact with skin and eyes! Ether should never be stored in containers for foodstuff! Danger to life!

Mode of operation

The ether starting device is used to inject an adjustable ether quantity into the cylinder of the Diesel pile hammer. The Diesel pile hammer will thus start easier (See Chapter 8.9 “Starting and Control”). The standard tripping height is not sufficient to start the Diesel pile hammer under unfavorable conditions (low temperature, driving of batter piles at a large batter). In these cases, the starting of the Diesel pile hammer will become possible with the ether starting device. Because of its low self-ignition temperature, the ether is used to achieve an ignition and to have the released piston raised to a sufficient height due to its explosion power. During the drop, the piston will then be able to sufficiently compress and ignite the injected fuel.

Installation

1. Remove the protective cap at the screw-in nozzle of the ether tank (B1)!
2. Screw the ether valve (B2) in!
3. Weld the supplied plate (B4) to the flange of the upper cylinder. The plate (B4) must be vertical below the ether valve (B2)! The plate is used to guide the cable.

4. Guide the supplied cable (B12) through the plate (B4)!
5. Attach the upper cable end to the ether valve (B2)!
6. Turn the screw-in nozzle (B8) into the lower cylinder!
7. Push the screw cap (B10) and the cutting ring (B9) onto the supplied elbow (B11)!

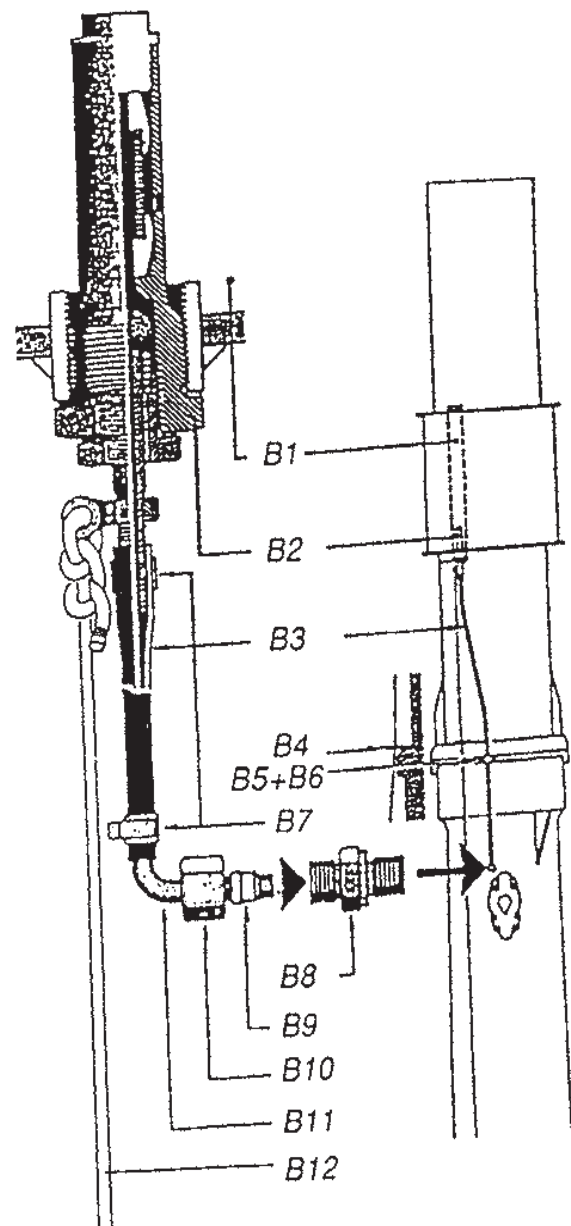

Other starting device for the Diesel pile hammers

8. Screw the screw cap (B10) onto the screw in nozzle (B8)!
9. Connect the elbow (B11) and the ether valve (B2) using the connection hose (B3)!
10. Secure the two hose ends using the hose clamps (B7)!
11. Attach the connection hose (B3) to the flange of the upper cylinder using the hose clip (B5)! To achieve this, drill a M8x12/16 thread (M8 thread, 12 mm deep, core hole depth 16 mm) into the flange of the upper cylinder! Using an M8 screw (B6), attach the connection hose (B3) and the hose clip (B5) to it!
12. Fill the ether tank with ether!

5. Without delay if possible, lift the piston to the tripping point (See Chapter 8.6 "Tripping device")!

The ether quantity was sufficient, if the piston has reached the required drop height (Lifting groove in the piston protrudes approximately 28 to 39 inches (70 to 100 cm) beyond the edge of the upper cylinder). Ignore work steps 6. and 7. in this case!

6. Lift the piston to the tripping point (See Chapter 8.6 "Tripping device")! The ether residues can be burned using a "cold blow".
7. Repeat work steps 3 through 5 and increase the ether supply in intervals of 0.5 seconds until the piston reaches the required drop height! Remember or make a note of the opening duration used the last time!

Operation

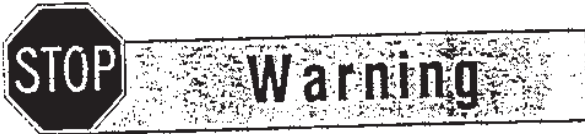

Apply only a small ether quantity initially! Otherwise, the piston may bounce into the catch groove! Danger of accident!

1. Clean the combustion chamber (See Chapter 8.8 "Clean combustion chamber")!
2. Set the fuel control pump to setting "0" (See Chapter 8.7 "Fuel supply control")!
3. Lift the piston to just before the tripping point (See Chapter 8.6 "Tripping device")!
4. Open the ether valve by pulling on the cable (B12) for the periods indicated below:

Type	Opening duration
D5 through D19	0.5 seconds
D25 through D30	1.0 seconds
D36 through D46	2.0 seconds
D62 through D100	2.5 seconds

8. Let the piston come to rest on the impact block!
9. Set the fuel control pump to setting "4" for a newly placed pile "3" for an already driven pile

(See Chapter 8.7 "Fuel supply control")!

10. Pull the rope for the shut off valve at the fuel control pump and keep it taut!
11. Repeat work steps 3. through 5. with the previously noted opening duration! Immediately let go of the cable for the shut off valve at the fuel control pump as soon as the piston has bounced to the upper highest point!
12. If the Diesel pile hammer still does not start, work steps 6. through 12. must be repeated.

Test stand for fuel control pump

Test unit for the fuel control pumps (Order No. 63417)



Read and observe the operating instructions “Diesel Pile hammers” as well as all safety instructions contained in them!

Fuel must be handled carefully! Take appropriate measures to prevent a spilling, igniting, inhaling and swallowing as well as contact with skin and eyes! Fuel should never be stored in containers for foodstuff! Danger to life!

Mode of operation

This test unit for fuel control pumps will enable you to accurately measure the fuel injection quantity per stroke (See Chapter 9.2 “Blow energy stages”) and to make the adjustment at the fuel control pump (Do not confuse this with the control dimension! See also Chapter 12.5 “Pumps”).

Installation

Install the test unit for fuel control pumps in accordance with the illustration!

Operation

Observe the instructions and data indicated in Chapter 12.5 “Pumps”!

1. Set the fuel control pump to the setting “0” (See Chapter 8.7 “Fuel supply control”)!
2. Press the pump lever to stop using the actuating lever!
3. Unscrew the adjustment screw until the adjustment value is 1 5/8" (42 mm)!
4. Secure the adjustment screw with the help of the counter nut!
5. Empty the measuring glass!
6. Push the actuating lever once to the stop at the adjustment screw!
7. Read the injection quantity at the measuring glass scale!
8. Compare the injection quantity with the nominal quantity (See Chapter 9.2 “Blow energy stages”)! Repeat work steps 2. through 8. when the deviations exceed 10%!

Test stand for fuel control pump

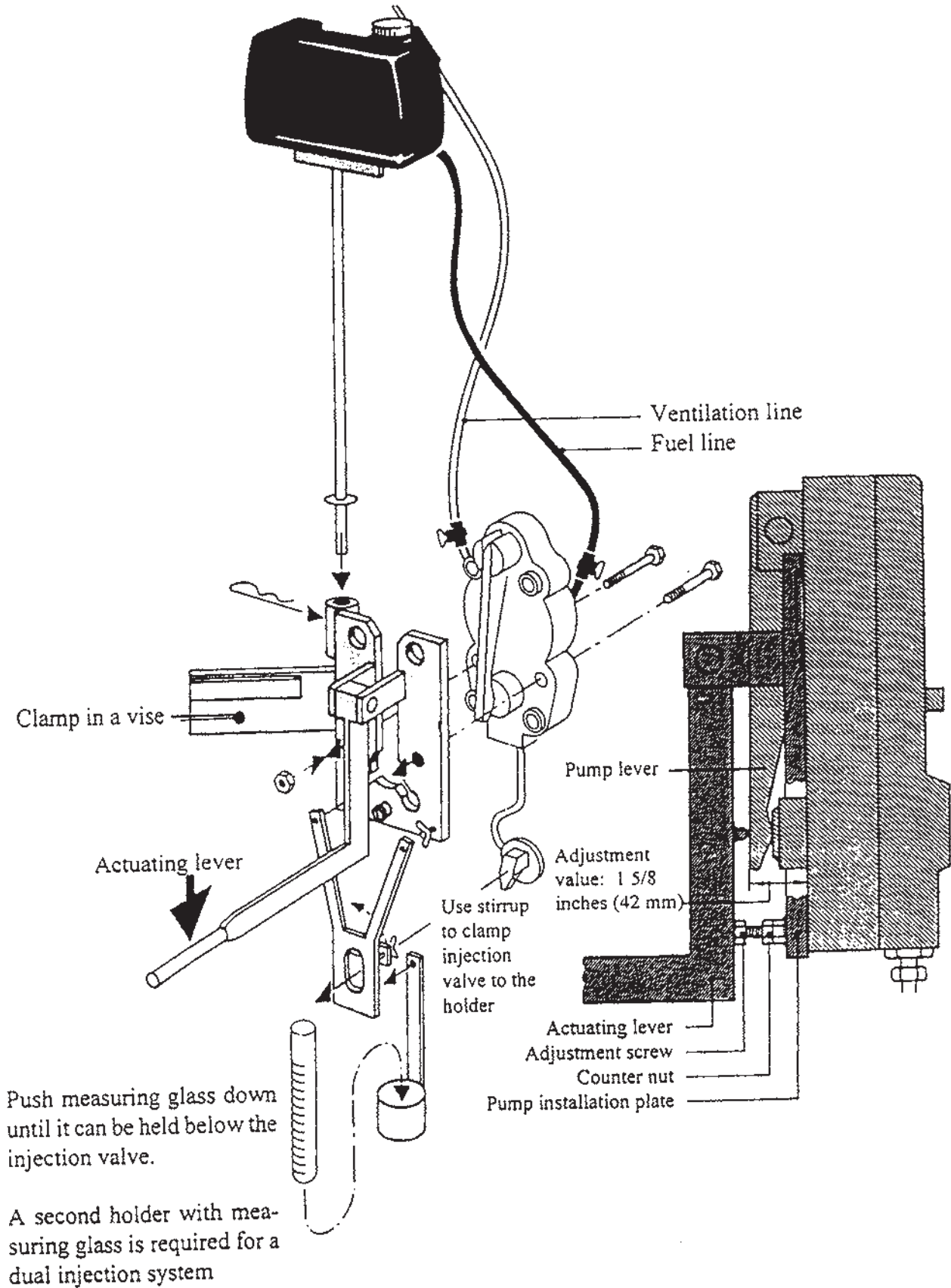

Lead profiles, standard dimensions for the diesel pile hammer

Lead profiles, standard dimensions for the Diesel pile hammer

Distance "A" from the center line of Diesel pile hammer to the front edge of the guide (mm)

Lead profile No.	Lead profile Figure	DELMAG lead system M = MH, MD, MS (MHG, MDG)	Diesel pile hammer type										
			D5	D6	D8	D12	D16 D19	D25 D30	D36 D46	D62	D80 D100		
1		M 2401 (MH 104) MDY 2401 (MD 194)			365	360							
2		M 2902 MDY 2902 (MD 198) M 30102 MY 30102 RH 0812/0912 RHV 0822/0922		335	360 465	320 360 465	340 395 500	360	435				
3		M 32103 G 420/421 RHV 0813/0823 RHV 1213 RH 1413/1423 RH 1433		400 560	440 440 560	400 475 595	440 500 680	455	440	500			
4		M 3504 (MH 112) M 35104 G 430/431		405	405	440	435 500 600	500 600	600				
5		M 3705 (MH 116) M 3905 (MH 300)			500	500	500	500 560	660 560 600 700	600 700	600 830		
7		M 37107 M 38107 M 39107 G 37107 RHV 1617/2117 G 36					500	500 640	660				
8		M 4408 G 45						515 750	750				
9		MD 22 G 421 special					400 456	400 500	435	435	475		
17 22		M 17/22 G 17/112 CR 22 CR 18			365 425 345 460	365 425 345 460 405	365 405 565 425 405	400 460 380 495	456 491 570 600 440	530 580	540 580		

Summaries - Applicable fuel types

A3 Summaries

A3.1 Applicable fuel types

It is quite common to operate the Diesel pile hammer with a mixture of summer Diesel fuel, winter Diesel fuel and additives (regular gasoline or engine petroleum) as a function of the temperature at the job site (See Chapter 8.4 “Bringing the Diesel pile hammer and pile helmet into the operating position”).

The possibility exists to use alternative fuels to conserve fossil fuels and to reduce air pollution. The table shown below lists the most important properties of some alternative fuels!

Soybean oil, refined

- Suitable as a replacement for Diesel fuel;
- Has been used in tests as a fuel for the combustion as well as a lubricant to lubricate the piston;
- Good and problem-free starting. Starting difficulties only around the freezing point (may require several starting attempts);
- No problems during operation;
- Barely measurable reduction in the output when compared to Diesel fuel (a decrease of 1-2 blows per minute);

- Less and brighter smoke; smoke emission increases after a continuous operation of four hours (However, it is still less than that for Diesel fuel);
- The maximum operating temperature is reached quicker than with Diesel fuel;
- No conversion is necessary for the pump element (same injection quantity as for Diesel fuel);
- Diesel pile hammer gets contaminated sooner (soybean oil is deposited in the form of a rubberlike mass); requires more frequent cleaning.

Rape oil, refined (Colza oil)

- Suitable as replacement for Diesel fuel;
- Problem-free combustion in the Diesel pile hammer despite its higher viscosity;
- Good and problem-free starting. Starting difficulties only around the freezing point (may require several starting attempts);
- No conversion is necessary for the pump element (same injection quantity as for Diesel fuel);
- Combustion, emission and output as for soybean oil.

Fuel	Calorific value (MJ/kg)	Density at 15° (kg/dm ³)	Viscosity at 20°C (mm ² /s)	Boiling Temp. (°C)
Diesel fuel	42.5	0.82-0.86	2.0-8.0	175-360
Soybean oil, refined	40.6	0.92	5.0-5.5	350
Rape oil, refined	37.7	0.92	67.0	200
Rape oil methyl ester	37.0	0.87-0.88	6.5-9.0	300
Methanol	19.7	0.80	0.7	65
n-butanol	33.1	0.81	3.6	118
Kerosene	43.5	0.77-0.83	4.0	170-260
Mixture of 50% Diesel fuel 50% n-butanol	37.8	0.83	4.0	170-260

Summaries - Applicable fuel types

Esterized soybean oil or rape oil

- Suitable as replacement for Diesel fuel;
- Lower viscosity than refined plant oils (can thus also be used at lower temperatures);
- Output reduction of 10% in comparison with refined plant oil;
- Slightly higher smoke emission than refined plant oil;
- Operating temperature (and thus number of blows) increases suddenly after approximately 1 hour of operation (best suited for short-term applications);
- No need to convert the pump element (same injection quantity as for Diesel fuel);
- Otherwise like refined plant oil.

Methanol

- Suitable as a replacement for Diesel fuel;
- Completely clean combustion (no smoke, no residues), lowest emission values (smog, carbon dioxide, ozone, nitrogen oxide);
- Consumption twice that of Diesel fuel. Requires conversion work to install a larger pump element!

- An ignition promoter with a corrosion inhibitor must be used due to its low ignition power.

Please note that most ignition promoters are poisonous! Follow the respective instructions issued by the manufacturer!

Kerosene

- Suitable as replacement for Diesel fuel;
- Lower smoke emission than Diesel fuel;
- Same output level as Diesel fuel;
- No need to convert pump element (same injection quantity as for Diesel fuel).

Mixture of n-butanol and Diesel fuel

- Not suitable as replacement for Diesel fuel;
- Most favorable mixing ratio is 1:1;
- Diesel pile hammer starts well when cold; fuel is burned with almost no residues;
- Temperature increases rapidly; major decrease in the output; strong increase in emissions.

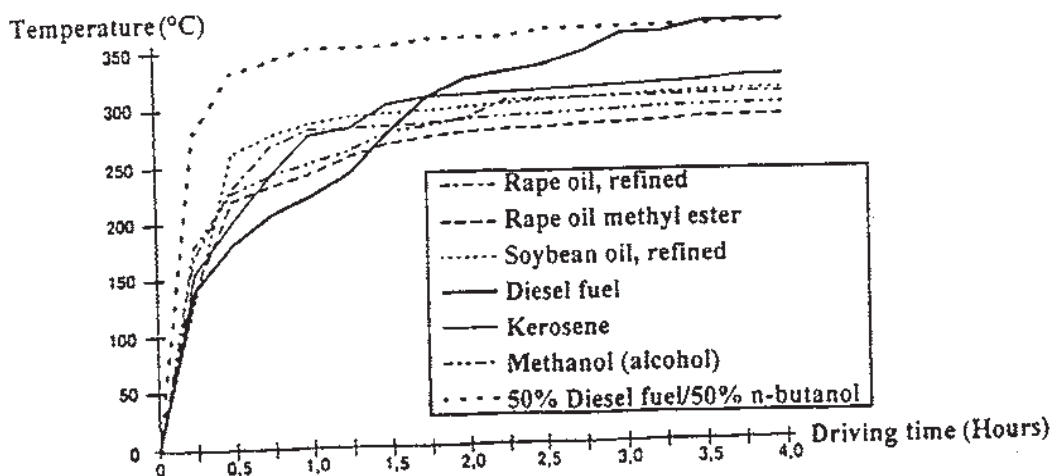

Reduction factors for different pile helmet cushions

Reduction factors for different pile helmet cushions

The use of different damping materials achieves different decreases in the blow force. Some examples are given in the following:

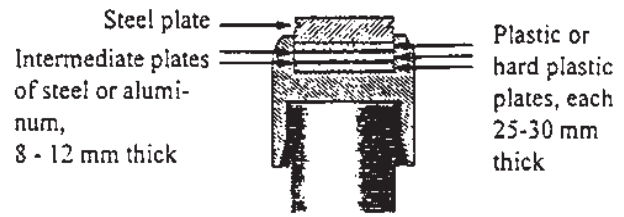

Reduction factor $R_f = 1.75$ to 2
 Hard plastic: Resitex Tx40, Novotex
 Plastic: Tufnol B 13
 Tufnol Vole Brand RCH 1000

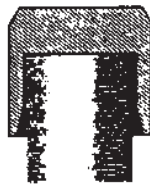

Reduction factor $R_f = 1.0$
 No cushion = max. blow force

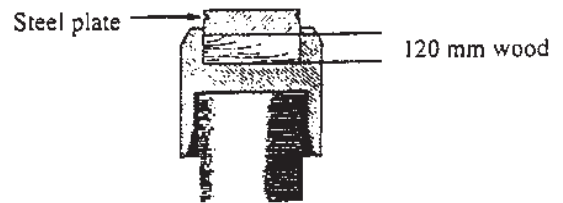

Reduction factor $R_f = 2.6$
 Wood: Bongossi
 Root wood (Beech or similar)

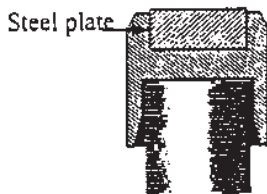

Reduction factor $R_f = 1.1$

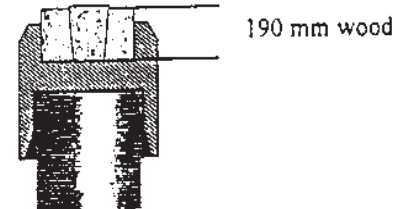

Reduction factor $R_f = 2.8$ to 3
 Wood: Bongossi
 Root wood (beech or similar)

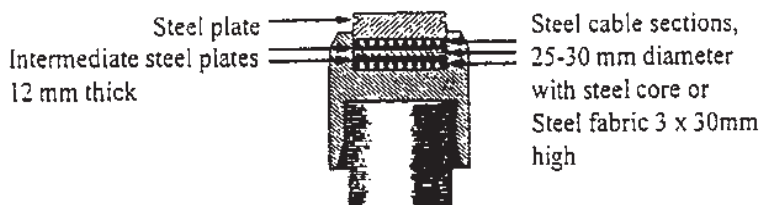

Reduction factor $R_f = 1.22$ (steel cable sections)
 Reduction factor $R_f = 1.42$ (steel fabric)

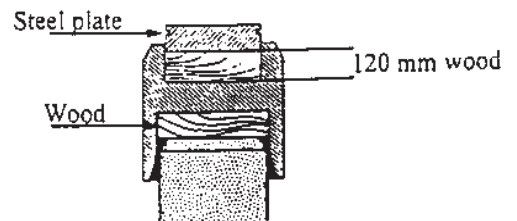

Reduction factor $R_f \sim 4.0$

Correlation between number of blows and drop height

Correlation between number of blows and drop height

The correlation between the number of blows (number of blows per minute) and the drop height of the piston is shown in the diagram below (does not apply to batter piles).

Number of blows
(Blows/Minute)

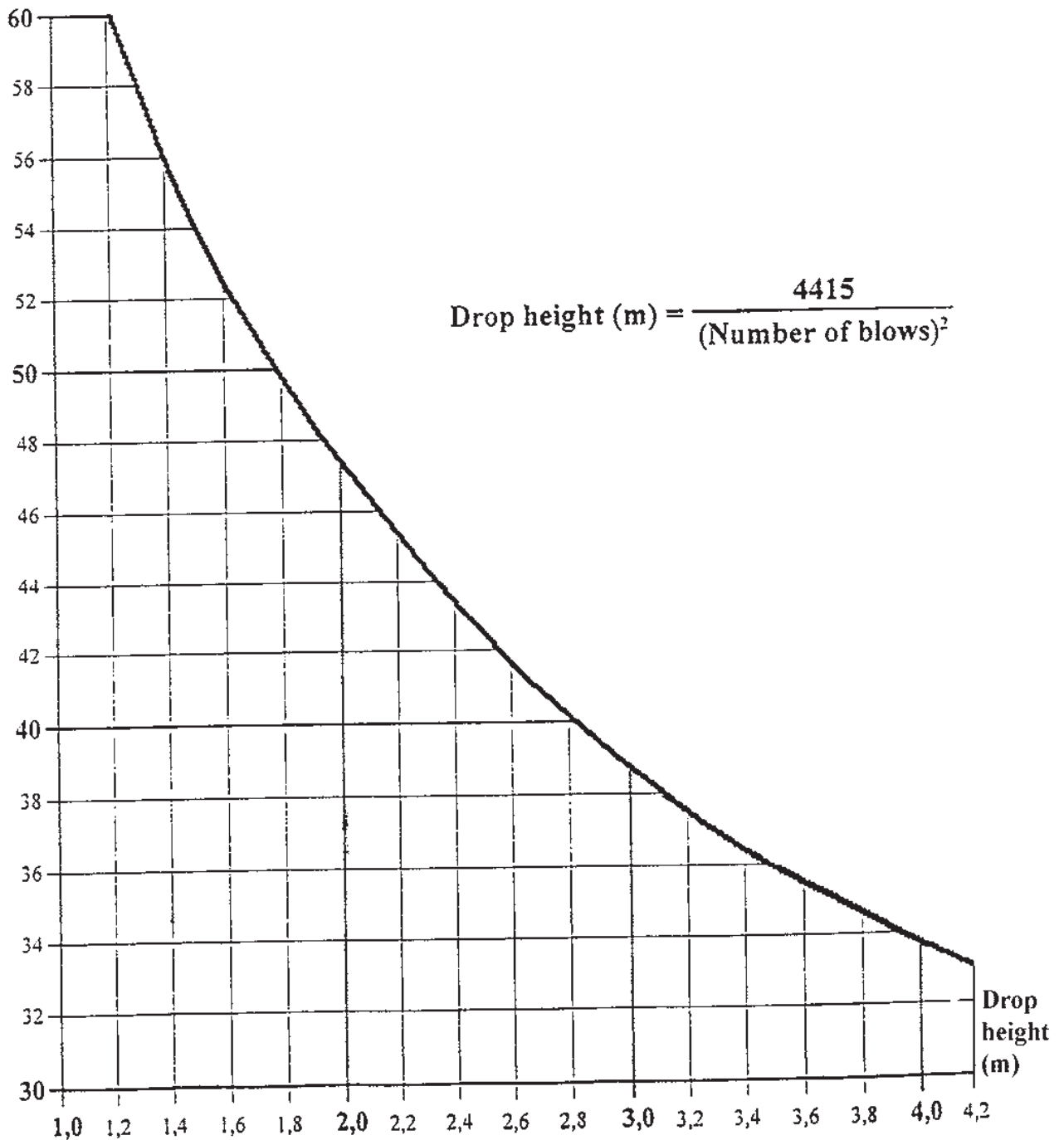

Correlation between number of blows and drop height

Drop height of DELMAG Diesel pile hammer

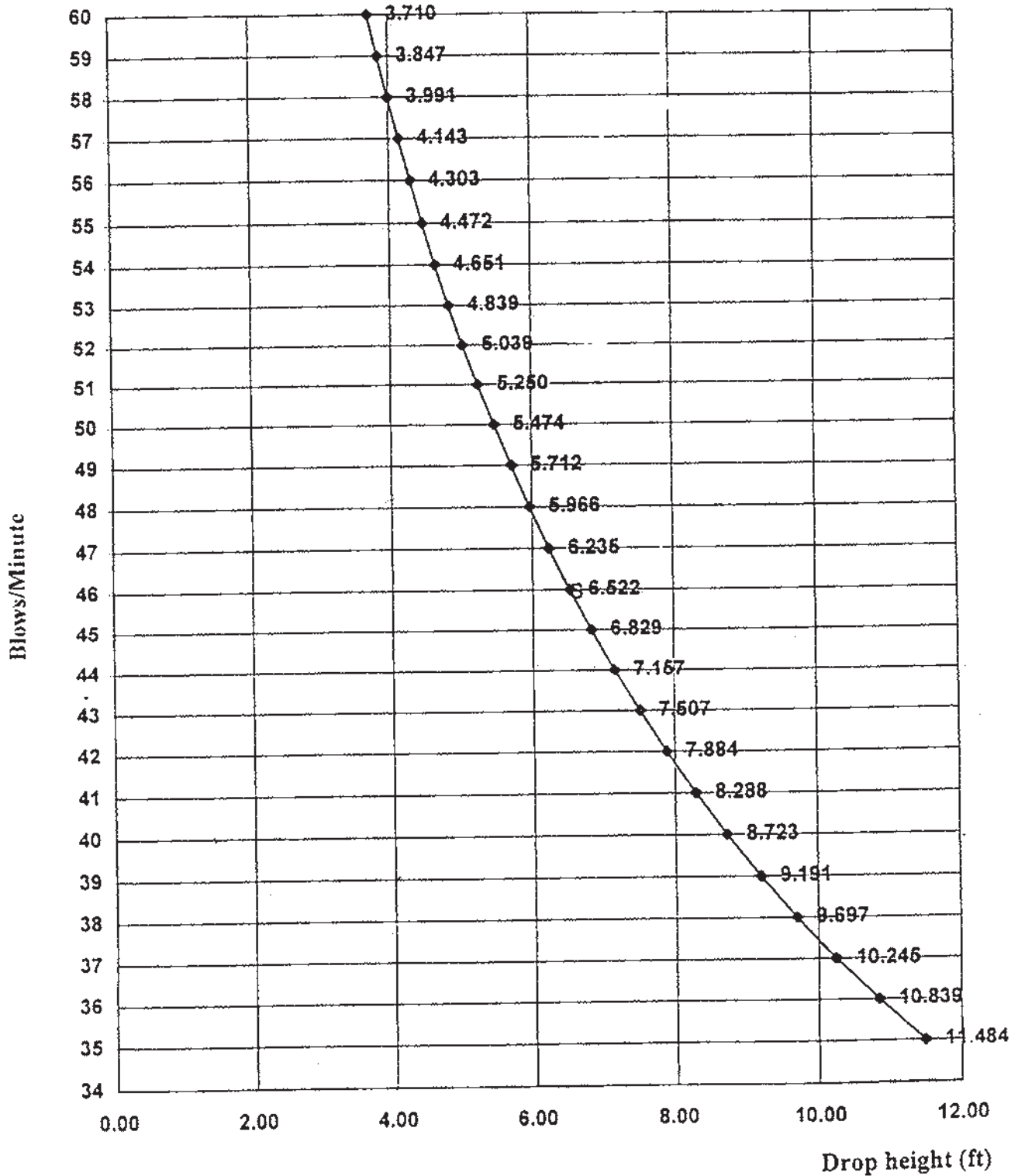

Accessories for diesel pile hammers

Accessories for Diesel pile hammers

The following summary lists the supplied standard accessories as well as optional accessories!

- Standard accessory
- Special accessory (sometimes a standard accessory, complete delivery on request)
- Optional accessory (supplied on request)

Guides for Diesel pile hammer	○
Conversion components for the driving of batter piles (extension of the upper cylinder, extension of the lubrication lines, connection elements)	○
Conversion components to convert series 32 to series 33 (2 drilled exhaust planes)	○
Complete fuel control pump, hydraulically regulated	○
Tripping device	●
Tripping device, guided at Diesel pile hammer (with guide strut)	○
Guide components for tripping device (guided at Diesel pile hammer with guide strut)	○
Pile helmet with pile helmet guide and pile helmet cushion	○
Transport brackets	○
Cable pulley hangers for the tripping device for multiple shearing	○
Tool box	●
Lubricants (some supplied with the tool box)	○
Ether starting device	○
Test unit for fuel control pump	○
Saximeter (monitor, see short description on next page)	○

Saximeter

Saximeter

The Saximeter is a monitor and auxiliary unit. It is available as an option. The following functions can be determined with the Saximeter:

- Automatic detection of hammer blows (alternate: as entered by pushing a button):
- Measuring the time intervals between blows:
- Calculating the number of blows (blows per minute)
- Calculating the blow energy:
- Aid for the evaluation of the actual settings:
- Aid in the detecting of safety risks.
- Showing drop height

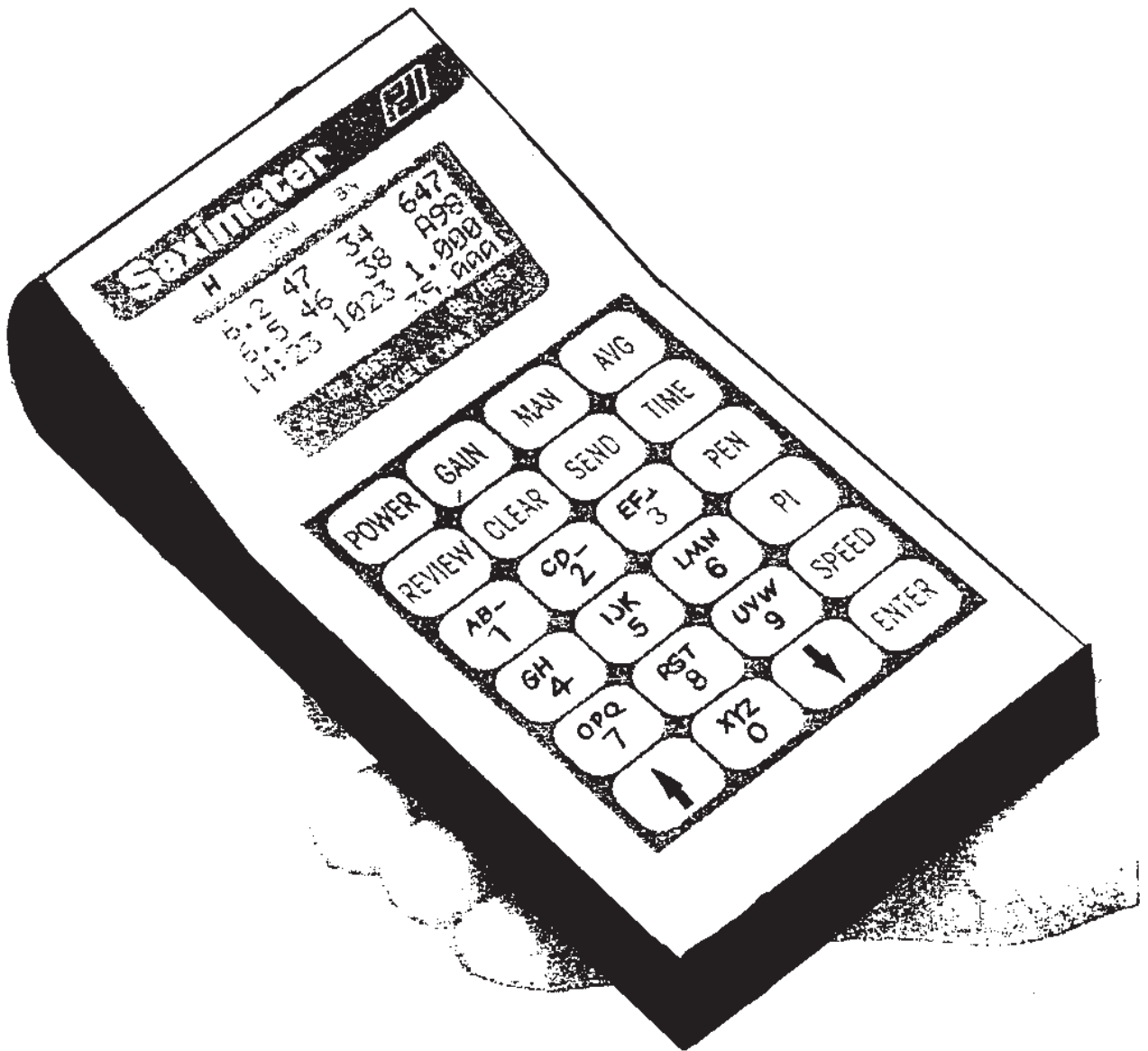

Sources

The regulations and standards indicated in these operating instructions are available from the following sources:

Accident Prevention Regulations

Carl Heymanns Verlag KG
Luxemburger Straße 449
50674 Cologne / Germany

(as well as from the appropriate trade union)

- VBG 1 "General Regulations"
- VBG 40 "Excavators, Loaders and special equipment used for earthwork"
- VBG 41 "Pile-driving work"
- Pamphlet "Earthwork equipment"
- Regulation "Safety regulations for work platforms on pile-driving and drilling equipment"
- No. 316

DIN Regulations

Beuth Verlag GmbH
Burggrafenstraße 4-10
10787 Berlin / Germany

DIN 15020 "Basic information for cable drives"
Sheet 2

Summary of diesel pile hammer types

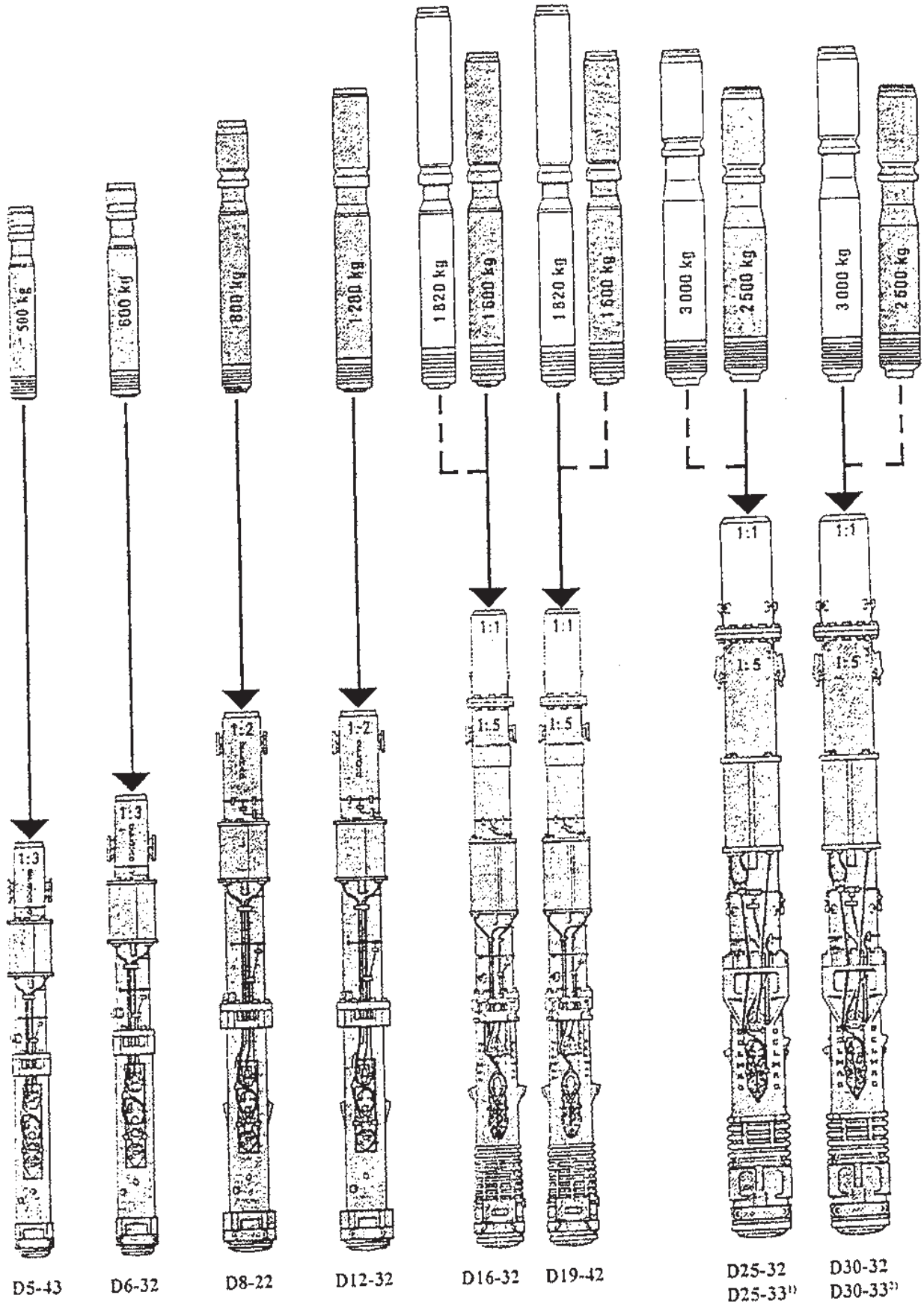

- 1) Can be converted to the next higher Diesel pile hammer type
- 2) Can be converted to the next lower Diesel pile hammer type

Summary of diesel pile hammer types

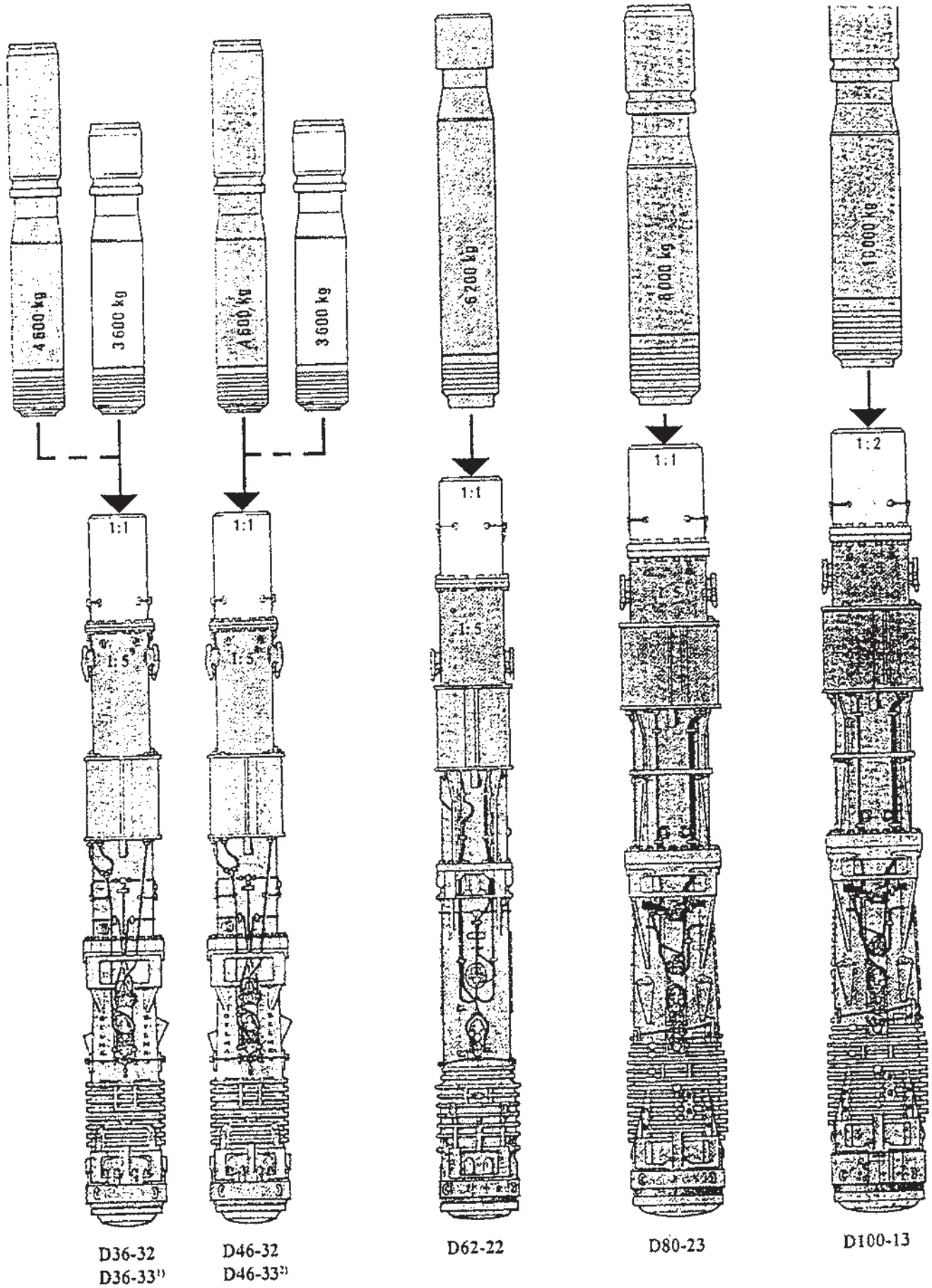

Form ,Operating instructions have been read and understood!‘

Form “Operating instructions have been read and understood”

I hereby declare that I have received instructions about the Diesel pile hammer prior to starting work. I have read and understood the operating instructions, particularly the safety instructions.

Date	Name	Job	Comments	Signature



APE - American Piledriving Equipment, INC.

7032 South 196th St. Kent,

WA 98032 USA

(800) 248-8498

(253) 872-0141

www.apevibro.com