



# OPERATION AND PARTS LIST MANUAL



SERIAL NUMBER:  
**H131**

**400 HYDRAULIC IMPACT HAMMER**



# OPERATION / MAINTENANCE MANUAL

MODEL 400 HYDRAULIC IMPACT HAMMER

7032 SOUTH 196th - KENT, WA 98032 - (800) 248-8498 / FAX (253) 872-8710

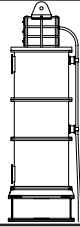

## Revision Record

Change Number	Page Number	Date	Revision Description



# OPERATION / MAINTENANCE MANUAL

MODEL 400 HYDRAULIC IMPACT HAMMER

7032 SOUTH 196th - KENT, WA 98032 - (800) 248-8498 / FAX (253) 872-8710

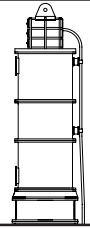

## Preface

### General

This manual covers the **Model 400 Hydraulic Impact Hammer**. The data provided in this manual gives the necessary information to operate and identify parts for this piece of APE equipment. The listed procedures are to be performed by qualified personnel who have an understanding of the equipment and who follow all safety precautions.

### Guide to Using the Manual

1. Refer to the Table of Contents for the page location of applicable sections.
2. All weights and measurements in this manual are in both English and Metric units.
3. The manual will be revised as necessary to reflect current information.

### Abbreviations

The following are abbreviations used within this manual.

<b>lb</b>	= Pounds	<b>kg</b>	= kilograms
<b>psi</b>	= Pounds per Square Inch	<b>kW</b>	= kilowatts
<b>bar</b>	= pressure (metric)	<b>kip</b>	= 1000 lbs
<b>hp</b>	= Horse Power	<b>lpm</b>	= liters per minute
<b>gpm</b>	= Gallons Per Minute	<b>mm</b>	= millimeters
<b>rpm</b>	= Revolutions Per Minute	<b>T</b>	=tons (US)
<b>eng.</b>	= Engine	<b>t</b>	= tonnes (metric)
<b>cyl.</b>	= Cylinder	<b>m</b>	= meters
<b>mm</b>	= Millimeter	<b>S/N</b>	= Serial Number
<b>mtg.</b>	= Mounting	<b>P/N</b>	= Part Number
<b>sol.</b>	= Solenoid	<b>mfg.</b>	= Manufacturer
<b>adj.</b>	= Adjustment	<b>OD</b>	= Outer Diameter
<b>CW</b>	= Clockwise	<b>ID</b>	= Inner Diameter
<b>CCW</b>	=Counter-Clockwise	<b>ft</b>	= feet
<b>HIH</b>	= Hydraulic Impact Hammer		



# OPERATION / MAINTENANCE MANUAL

MODEL 400 HYDRAULIC IMPACT HAMMER

7032 SOUTH 196th - KENT, WA 98032 - (800) 248-8498 / FAX (253) 872-8710

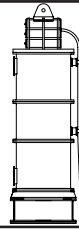

## Table of Contents

	Page
Revision Record .....	i
Preface .....	ii
Table of Contents .....	iii
Safety Precautions .....	v
Illustration List .....	vi
Table List .....	vi
Warranty .....	vii
<b>I. GENERAL INFORMATION .....</b>	<b>1-1</b>
I-1. Machine Features .....	1-1
I-2. Machine Specifications .....	1-2
I-3. General Description of HIH 400 .....	1-3
A. Lifting & Handling System .....	1-4
B. Ram / Main Cylinder .....	1-6
C. Stroke Control System .....	1-7
D. Striker Plate / Bell Housing .....	1-8
I-4. General Description of Model 1000 Power Unit .....	1-9
<b>II. PREPARING THE HIH 40 HAMMER .....</b>	<b>2-1</b>
II-1. Assembling the 400 .....	2-1
II-2. Plumbing the Hoses to the Power Unit .....	2-5
ii-3. Filling the Pressure Hose .....	2-6
II-4. Setting up Stroke Control & Visual Indication System .....	2-7
<b>III. RUNNING THE 400 HAMMER .....</b>	<b>3-1</b>
III-1. Selection of Control .....	3-1
III-2. Procedure to Run Hammer - Stroke of 3 ft or Less .....	3-2
III-3. Procedure to Run Hammer - Stroke of More than 3 ft .....	3-2
III-4. Shut-down Procedure .....	3-3
<b>IV. HYDRAULIC CIRCUIT .....</b>	<b>4-1</b>
IV-1. Circuit Diagram .....	4-1
<b>V. PARTS LIST .....</b>	<b>5-1</b>
V-1. Hammer Exterior Parts .....	5-1
V-2. Hammer Interior Parts & Sub-Assemblies .....	5-3
V-3. Spool Valve Assembly .....	5-5
V-4. Secondary Valve Assembly .....	5-7
V-5. Primary Valve Assembly .....	5-8
V-6. Hydraulic Cylinder (Main) .....	5-9
V-7. Trip Valve Assembly .....	5-10
V-8. Stroke Control Assembly .....	5-11



# OPERATION / MAINTENANCE MANUAL

MODEL 400 HYDRAULIC IMPACT HAMMER

7032 SOUTH 196th - KENT, WA 98032 - (800) 248-8498 / FAX (253) 872-8710

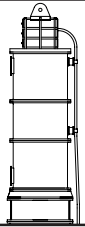

## Table of Contents (Continued...)

V. MAINTENANCE .....	TBD
VI. TROUBLESHOOTING .....	TBD



# OPERATION / MAINTENANCE MANUAL

MODEL 400 HYDRAULIC IMPACT HAMMER

7032 SOUTH 196th - KENT, WA 98032 - (800) 248-8498 / FAX (253) 872-8710

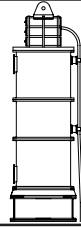

## Safety Precautions

This list of precautions must be followed at all times to ensure personal & equipment safety.

1. Read this manual from beginning to end before operating or working on this machine.
2. When operating in a closed area, direct the exhaust fumes outside, using pipes. (**WARNING:** Breathing exhaust fumes can cause serious injury and even death.)
3. Assure that there is proper ventilation when charging batteries.
4. Never adjust or repair the unit while it is in operation.
5. Never enter hammer housing when power unit is running.
6. Make sure the Control Panel is in the “OFF” position before starting the unit.
7. Remove all tools and electrical cords before starting the power unit.
8. Keep oily rags away from the exhaust system.
9. Never store flammable liquids near the engine.
10. Never stand under impact hammer at any time. Keep your eyes on the hammer when it is in operation. Keep a look out for loose bolts or leaking hydraulic lines.
11. Avoid pulling on hose quick disconnect fittings. Move power unit closer to work if hoses cannot reach. Do not use hoses as a tow line to tug the power unit!
12. Avoid kinks in the hoses. Kinks will cut the hose safety factor by 50 percent.
13. Always wear ear protection.
14. Avoid standing downwind of piles during driving. Dirt and other matter may become airborne and fall into the unprotected eye.
15. Always wear a hardhat, gloves and safety shoes.
16. Always attach safety line to pile when extracting or hoisting into position.
17. Lay hammer down in cradle when not in use.
18. Do not transport power unit with quick disconnect caps and plugs screwed on to fittings unless the caps and plugs have wire rope safety lines attached. Store in storage box under control panel.
19. Follow the daily maintenance required prior to operation.
20. Follow the start-up procedures listed in the manual for the power unit being used.
21. Start with piles in good condition.
22. Keep piles plumb with pile guide(s).
23. Start slow. Come up to speed before doing hard driving.



# OPERATION / MAINTENANCE MANUAL

MODEL 400 HYDRAULIC IMPACT HAMMER

7032 SOUTH 196th - KENT, WA 98032 - (800) 248-8498 / FAX (253) 872-8710

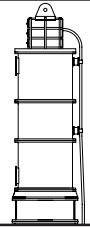

## Illustration List

Figure	Title	Page
1-A.	Machine Features .....	1-1
1-B.	General Description of 400 Hammer .....	1-3
1-C.	General Description of Lifting & Handling .....	1-5
1-D.	General Description of Ram / Main Cylinder .....	1-6
1-E.	General Description of Stroke Control System .....	1-7
1-F.	General Description of Striker Plate / Bell Housing .....	1-8
1-G.	General Description of Model 1000 Power Unit .....	1-9
2-A.	Lifting Main Cage .....	2-2
2-B.	Adjusting Stroke Control Cam Valve .....	2-3
2-C.	Installing Lifting Cushions, Nuts & Bolts .....	2-3
2-D.	Placing the Hammer in the Cradle .....	2-4
2-E.	Checking the Top Retainer Plate .....	2-4
2-F.	Power Unit Coupler Layout .....	2-5
2-G.	Visual Stroke Indicator Cylinder .....	2-7
2-H.	Visual Stroke Indicator Cylinder .....	2-7
2-J.	Stroke Indicator & Control System Schematic .....	2-8
3-A.	Selection of Control .....	3-1
4-A.	Hydraulic Circuit .....	4-1
5-A.	Hammer Exterior Parts .....	5-1
5-B.	Hammer Interior Parts & Sub-Assemblies .....	5-3
5-C.	Spool Valve Assembly .....	5-5
5-D.	Secondary Valve Assembly .....	5-7
5-E.	Primary Valve Assembly .....	5-8
5-F.	Hydraulic Cylinder (Main) .....	5-9
5-G.	Trip Valve Assembly .....	5-10
5-H.	Stroke Control Assembly .....	5-11
5-J.	Stroke Control Assembly Details .....	5-12

## Table List

Table	Title	Page
1-A	Model 400 Machine Specifications .....	1-2
5-A	Hammer Exterior Parts List .....	5-2
5-B	Hammer Interior & Sub-Assemblies .....	5-4
5-C	Spool Valve Assembly .....	5-6
5-D	Secondary Valve Assembly .....	5-7
5-E	Primary Valve Assembly .....	5-8
5-F	Hydraulic Cylinder (Main) .....	5-9
5-G	Trip Valve Assembly .....	5-10
5-H	Stroke Control Assembly .....	5-12



# OPERATION / MAINTENANCE MANUAL

MODEL 400 HYDRAULIC IMPACT HAMMER

7032 SOUTH 196th - KENT, WA 98032 - (800) 248-8498 / FAX (253) 872-8710

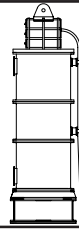

## Warranty

### American Piledriving Equipment, Inc. STANDARD WARRANTY

American Piledriving Equipment, Inc. (APE) warrants new products sold by it to be free from defects in material or workmanship for a period of one year after the date of delivery to the first user and subject to the following conditions:

APE's obligation and liability under this WARRANTY is expressly limited to repairing or replacing at APE's option, any parts which appear to APE upon inspection to have been defective in material or workmanship. Such parts shall be provided at no cost to the user, at the business establishment of APE or the authorized APE distributor of the product during regular working hours. **This WARRANTY, shall not apply to component parts or accessories of products not manufactured by APE** and which carry the warranty of the manufacturer thereof, or to normal maintenance (such as engine tune-up) or normal maintenance parts (such as filters). Replacement or repair parts installed in the product covered by this WARRANTY are warranted only for the remainder of the warranty as if such parts were original components of said product. AMERICAN PILEDIVING EQUIPMENT, INC. makes no other warranty, expressed or implied and makes no warranty of merchantability of fitness for any particular purpose.

APE's obligation under this WARRANTY shall not include any transportation charges, costs of installation, duty, taxes or any other charges whatsoever, or any liability for direct, indirect, incidental or consequential damage or delay. If requested by APE, products or parts for which a warranty claim is made are to be returned transportation prepaid to APE. Any improper use, including operation after discovery of defective or worn parts, operation beyond rated capacity, substitution of any parts whatsoever, or parts not approved by APE or any alteration or repair by others in such manner as in APE's judgment affects the product materially and adversely, shall void this warranty.

**NO EMPLOYEE OR REPRESENTATIVE IS AUTHORIZED TO CHANGE THIS WARRANTY IN ANY WAY OR GRANT ANY OTHER WARRANTY UNLESS SUCH CHANGE IS MADE IN WRITING AND SIGNED BY AN OFFICER OF APE, INC.**

**ANY TYPE OF WELDING ON EQUIPMENT  
WILL VOID THE WARRANTY**





# OPERATION / MAINTENANCE MANUAL

MODEL 400 HYDRAULIC IMPACT HAMMER

7032 SOUTH 196th - KENT, WA 98032 - (800) 248-8498 / FAX (253) 872-8710

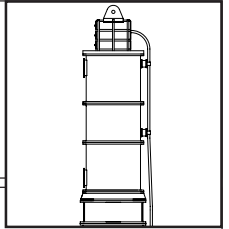

## I. GENERAL INFORMATION

### I-1. Machine Features - Model 400 Hydraulic Impact Hammer

High volume accumulators are placed close to lifting cylinder to enhance cycle rate.

Shorter than other hammers in its class, resulting in more headroom and reach.

Heavy duty lifting section with 150 ton shackle and pin.

Double-cushioned head design isolates impact vibration from cylinder and external structure.

Ram is contained internally in steel housing. This protects the ram and control system, and eliminates guide rods and cables.

Hydraulic control spool valve has proven history of reliable operation, eliminating all electrical wires and electronic sensors.

Modular sections allow for custom breakdown for ease of shipping and interstate trucking.

Forged ram is low-headroom. Ram is bored to allow it to slide over lifting cylinder.

Internal ram guides are vertical and continuous, greasable from the outside.

Hydraulic cylinder operates on biodegradable vegetable oil, ensuring minimal environmental impact should a spill or leak occur.

Multiple access hatches are provided for access to control and lifting cylinders.

Lifting lugs are provided at bottom of hammer to allow for lifting options or support during battered driving operations.

Rebound cushions isolate impact forces from hammer when pile seats against the striker plate.

Bell housing is adjustable to allow for driving of several different pile sizes.

Striker plate is forged, and fully contained in a modular housing.

Heavy-duty trunions allow hammer to be rotated to horizontal position for storage and maintenance.

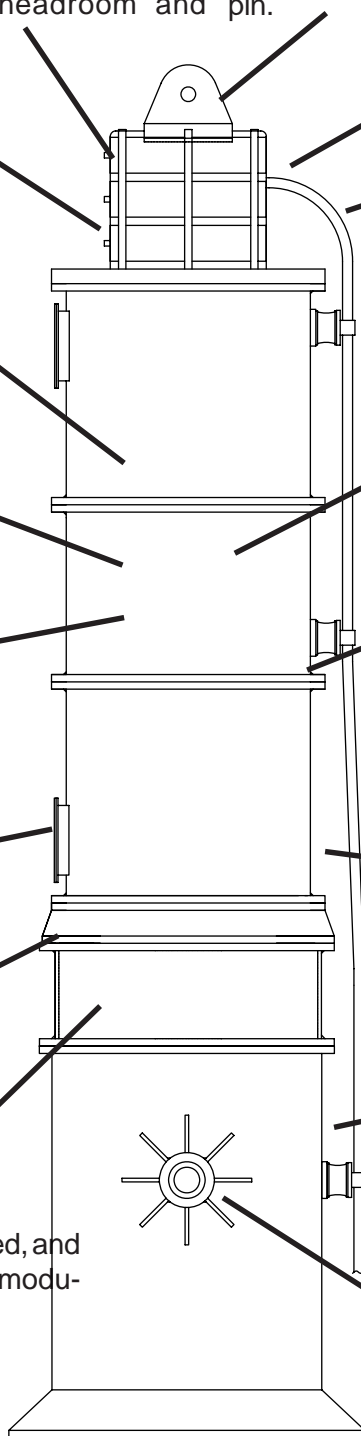

Figure 1-A. Machine Features



# OPERATION / MAINTENANCE MANUAL

MODEL 400 HYDRAULIC IMPACT HAMMER

7032 SOUTH 196th - KENT, WA 98032 - (800) 248-8498 / FAX (253) 872-8710

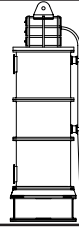

## I. GENERAL INFORMATION (Continued...)

### I-2. Model 400 Impact Hammer Specifications - (Table 1-A)

<u>Dimensional Data</u>	<u>Units (US)</u>		<u>Units (SI)</u>
Overall Height (Base to Hook)	30.5	ft	9.30 m
Bell Height	8.92	ft	2.72 m
Bell ID (Max Pile Diameter)	74.0	in	1.88 m
Striker Plate Housing Height	28.0	in	0.71 m
Striker Plate Housing OD	73.0	in	1.85 m
Striker Plate Height	12.0	in	0.30 m
Striker Plate Diameter	70.0	in	1.78 m
Cage Section Height	14.1	ft	4.29 m
Cage Max. OD	75.0	in	1.91 m
Ram Length	120.0	in	3.05 m
Ram Max. OD	60	in	1.52 m
<u>Weight Data</u>	<u>Units (US)</u>		<u>Units (SI)</u>
Overall Weight	140	kips	63.7 t
Striker Plate Weight	13	kips	5.91 t
Ram Weight	120	kips	36.4 t
<u>Performance Data</u>	<u>Units (US)</u>		<u>Units (SI)</u>
Maximum Stroke	5.0	ft	1.52 m
Minimum Stroke	1.0	ft	0.30 m
Maximum Calc. Energy	400,000	ft-lb	542 kN-m
Minimum Calc. Energy	80,000	ft-lb	108 kN-m
Max. System Pressure	4500	psi	310 bar

**Dimensions may vary depending on the year and model.  
 Consult the factory for certifications on unit being used.**



# OPERATION / MAINTENANCE MANUAL

MODEL 400 HYDRAULIC IMPACT HAMMER

7032 SOUTH 196th - KENT, WA 98032 - (800) 248-8498 / FAX (253) 872-8710

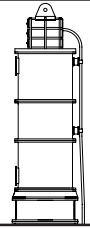

## I. GENERAL INFORMATION (Continued...)

### I-3. General Description of Model 400 Hydraulic Impact Hammer

The **APE Model 400** is a variable stroke, hydraulically-operated and controlled pile driver. In addition, the hammer can be used for soil compaction, installing well casings and testing piers.

The Model 400 operates in a range of approximately 20 to 60 cycles per minute depending on the hydraulic flow and desired stroke. The Model 400 is especially suited for driving large diameter piles and caissons.

The four major parts to the Model 400 are as follows:

- A) The Lifting & Handling System / Cage
- B) The Ram / Main Cylinder
- C) The Stroke Control System
- D) The Striker Plate / Bell

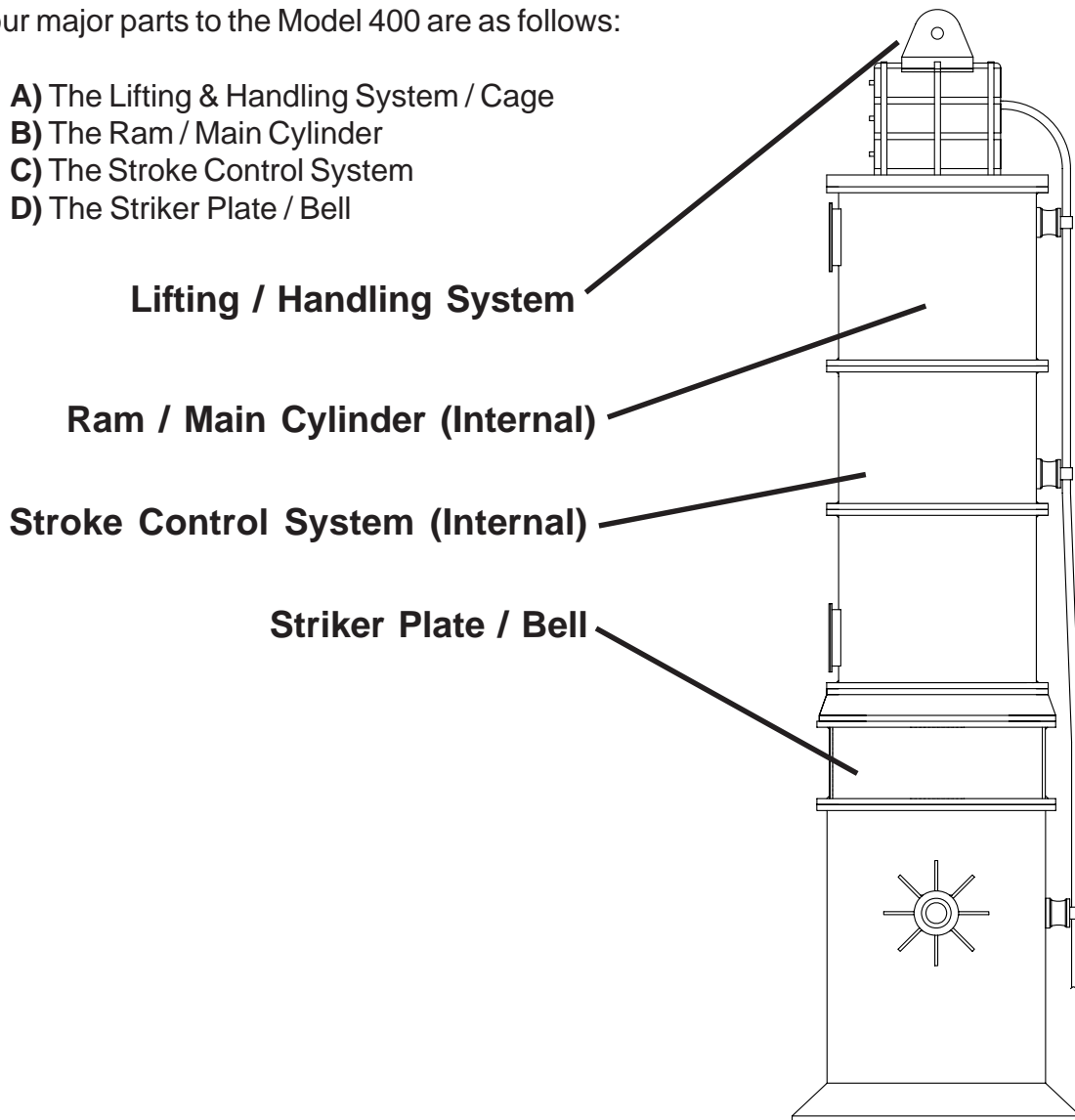

**Figure 1-B. General Description of 400 Hammer**



# OPERATION / MAINTENANCE MANUAL

MODEL 400 HYDRAULIC IMPACT HAMMER

7032 SOUTH 196th - KENT, WA 98032 - (800) 248-8498 / FAX (253) 872-8710

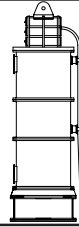

## I. GENERAL INFORMATION (Continued...)

### I-3A. The Lifting & Handling System / Cage Housing

The lifting system consists of a 150 ton (140 t) hook, attached to an assembly of plates at the top of the hammer, which allows the full weight of the hammer to be lifted vertically and set on top of a pile. There are also lifting lugs at the bottom of the main cage to assist in alignment of the hammer if needed. The heavy duty trunnions at the base of the bell section permit the hammer to be set on a cradle and rotated to horizontal for storage and / or maintenance.

#### **CAUTION!**

#### **DURING LIFTING:**

The rigging from the crane to the hammer must be rated for the load of the full hammer weight plus any expected impact factor. The lifting must be conducted smoothly so as to minimize impact forces in the rigging.

#### **DURING DRIVING:**

When driving a pile, the crane operator must watch the rigging very carefully, and maintain a small amount of slack in the rigging. If there is no slack in the rigging during driving, the striker plate might not be fully seated. The ram will over-stroke and damage the hammer internally.

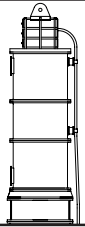

## I. GENERAL INFORMATION (Continued...)

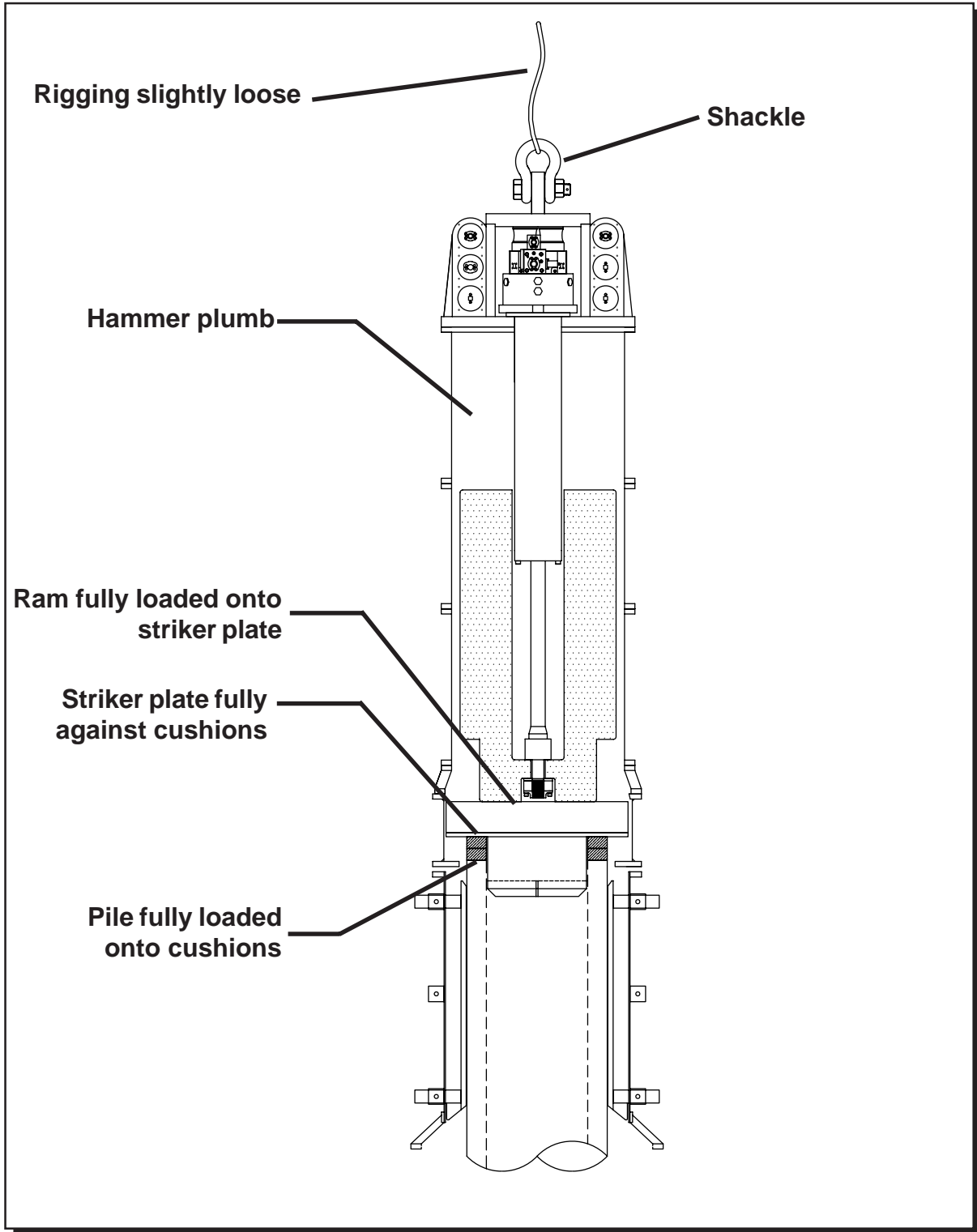

**Figure 1-C. General Description of Handling  
 (Proper Position for Driving)**



# OPERATION / MAINTENANCE MANUAL

MODEL 400 HYDRAULIC IMPACT HAMMER

7032 SOUTH 196th - KENT, WA 98032 - (800) 248-8498 / FAX (253) 872-8710

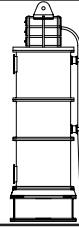

## I. GENERAL INFORMATION (Continued...)

### I-3B. Ram / Main Cylinder

Hydraulic oil is pumped from the power unit drive pumps (and assisted by the high-pressure accumulators) into the main cylinder, lifting the ram. The ram continues to rise to a point determined by the stroke control cylinder (see next section). At that point hydraulic oil flow to the main cylinder is cut off, and the ram is allowed to drop. The ram falls, and the impact of the ram (onto the striker plate) transmits energy to the pile. After the impact, the cycle is repeated automatically with no action required of the operator.

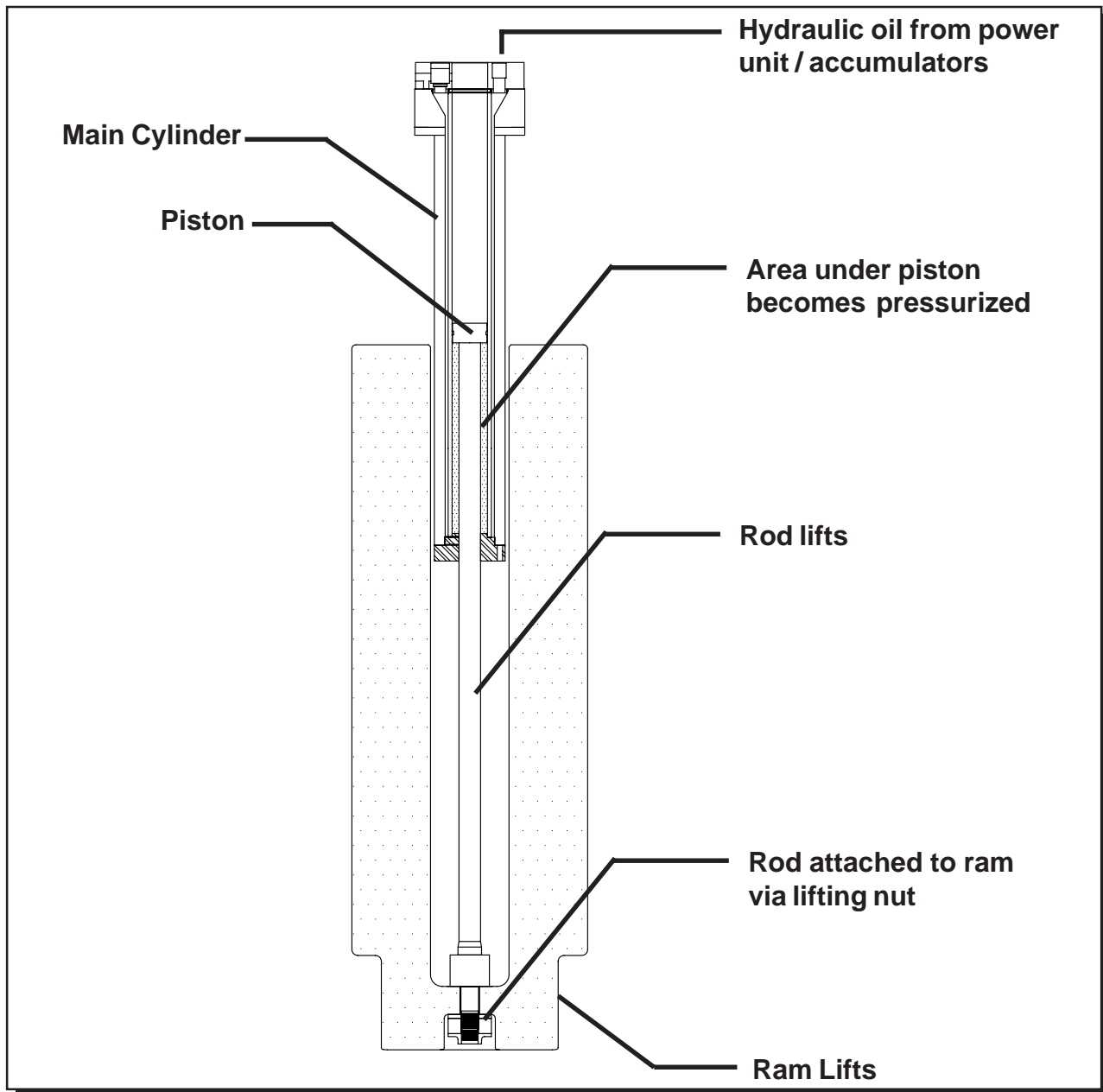

**Figure 1-D. General Description of Ram / Main Cylinder**

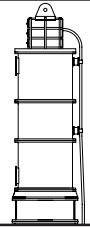

### I. GENERAL INFORMATION (Continued...)

#### I-3C. Stroke Control System

The stroke control system pre-sets the stroke height of the ram, and is adjustable, either before, or during the operation of the hammer. The stroke control system consists of a small hydraulic cylinder, mounted inside the hammer cage, which is operated by the power unit clamp circuit. The cylinder raises and lowers a swing arm, which is connected to the cylinder rod. A mobile ground device is slaved to this rod, permitting the operator to see the desired stroke.

The swing arm is positioned in the path of the ram, such that the ram contacts the swing arm on each stroke. The swing arm then presses a cable, which actuates a cam at the top of the hammer. The cam depresses a plunger type directional valve, which in turn pilots the main control valve. Note that the cylinder is used for positioning the swing arm only, and is not under continuous operation.

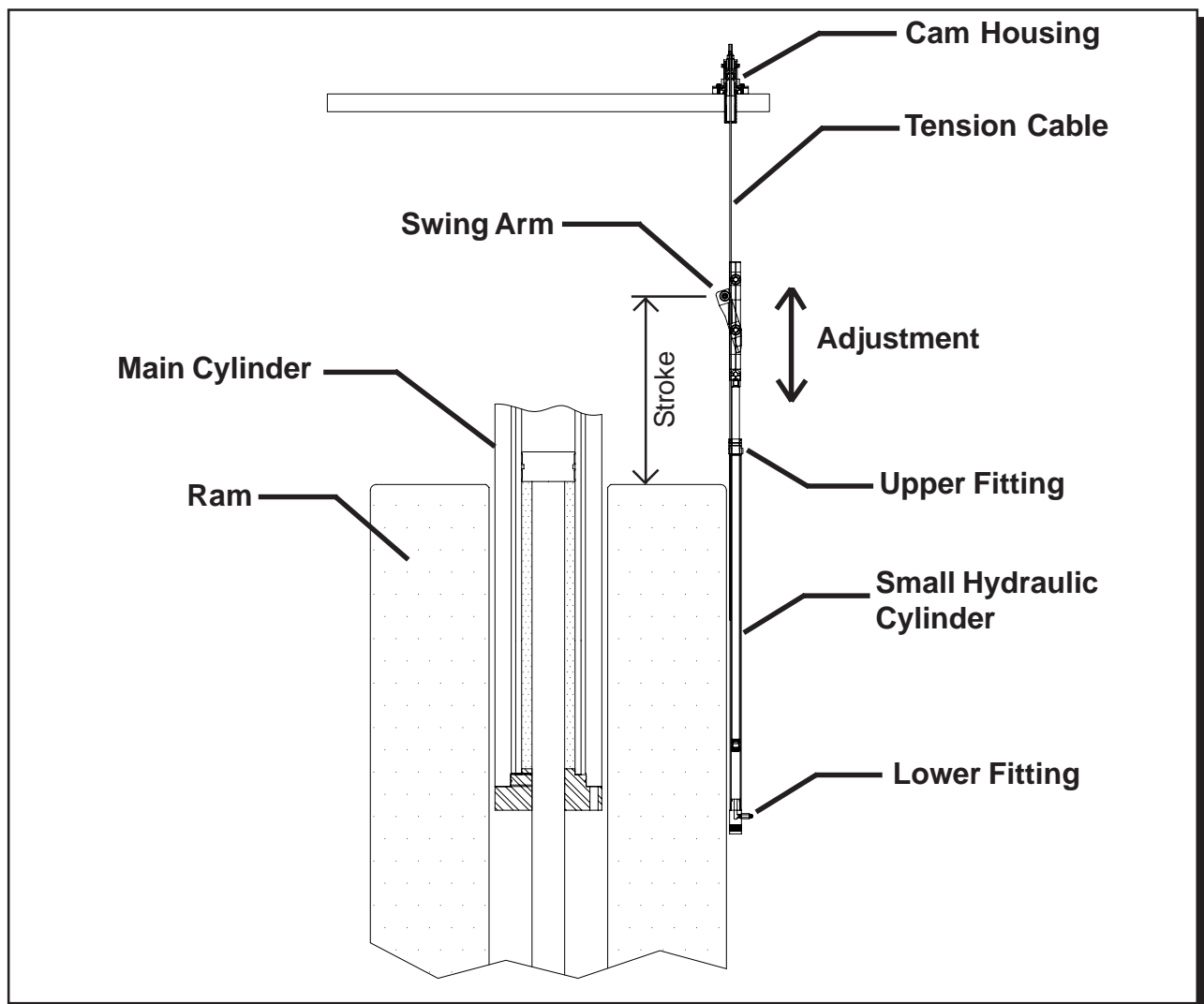

**Figure 1-E. General Description of Stroke Control System**



# OPERATION / MAINTENANCE MANUAL

MODEL 400 HYDRAULIC IMPACT HAMMER

7032 SOUTH 196th - KENT, WA 98032 - (800) 248-8498 / FAX (253) 872-8710

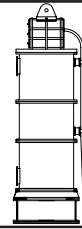

## I. GENERAL INFORMATION (Continued...)

### I-3D. Striker Plate / Bell Housing

The HIH 400 is a direct drive hammer, which may be operated without a set of leads. The ram directly hits the striker plate, which in turn directly strikes the pile, or a cushion system if desired. The bell housing guides to the pile, and holds the hammer plumb. The bell housing is tapered to allow easy loading of the hammer onto the pile. The bell housing is adjustable, and will guide to a variety of pile sizes.

**IMPORTANT:** The actual diameter of the pile must be measured so that the guides in the bell housing can be adjusted or shimmed for a snug fit. The top of the pile must be checked for squareness and uniformity. Proper and safe driving will result only if there is continuous uniform contact between the top of the pile and the bottom of the striker plate / cushion..

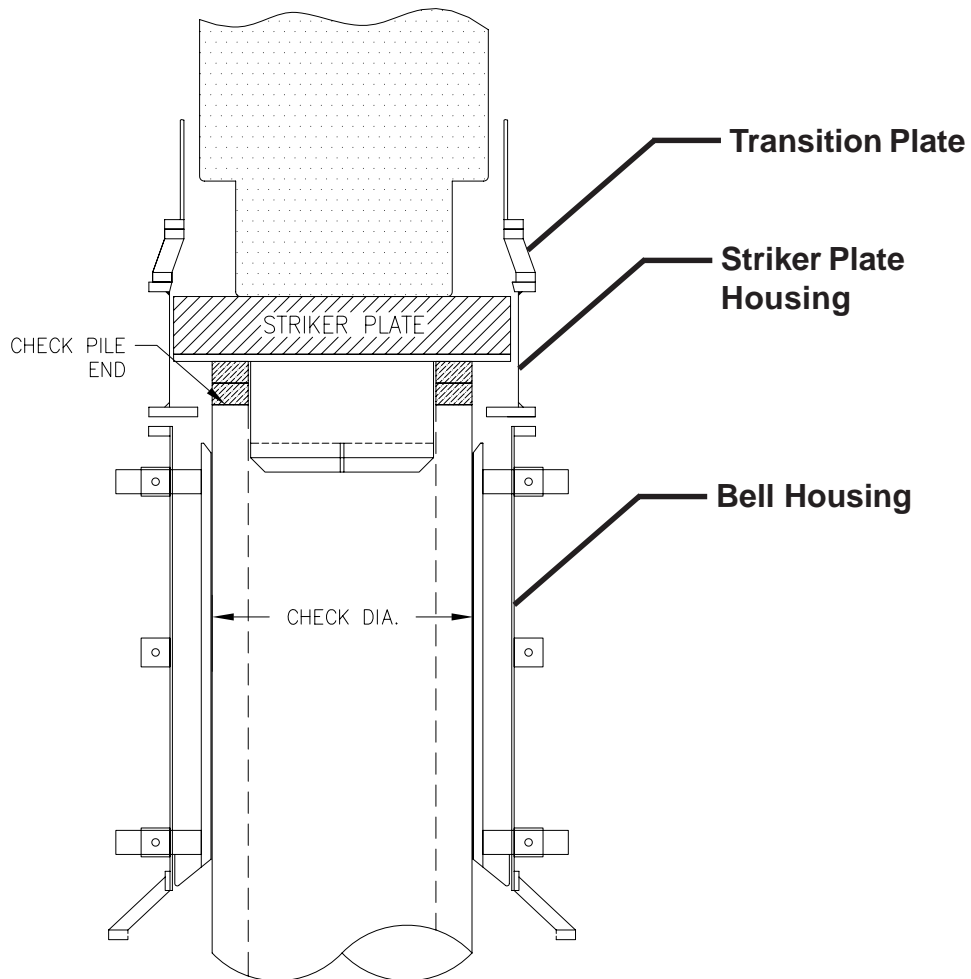

**Figure 1-F. General Description of Striker Plate / Bell Housing**





# OPERATION / MAINTENANCE MANUAL

MODEL 400 HYDRAULIC IMPACT HAMMER

7032 SOUTH 196th - KENT, WA 98032 - (800) 248-8498 / FAX (253) 872-8710

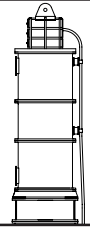

## I. GENERAL INFORMATION (Continued...)

### I-4. General Description of Model 1000 Power Unit

The HIH 400 runs off the APE 1000 power unit. The APE 1000 has a CAT 1000 horsepower engine. The engine is mounted to a tubular frame that also serves as a diesel fuel tank. A sheet metal and tube frame covers the engine and is equipped with locking doors for protection from the environment. A control panel is located behind one of the doors and comes complete with a 50 foot (15m) control pendant. There are two hydraulic tanks on the power unit. One is the main tank and the other is a storage tank for extra oil in case the main tank becomes depleted.

The HIH 400 is connected to the power unit via four hydraulic hoses.

**HOSES** - One 2" ID (38mm) hose is the pressure line and the other 2" ID (50mm) is the return line for the main hydraulic cylinder. The two 3/8" ID (9.5mm) hoses are for the stroke control system. The hoses are attached to the power unit by connecting the "quick disconnect fittings" on the end of the hoses leading from the hammer. The fittings go on only one way so there is no chance of hooking up the hoses improperly.

**WARNING:** Before installing quick disconnects, clean with ether or a clean rag. Make sure the the quick disconnect fittings are fully seated. Failure to tighten the quick disconnects will stop the flow of oil and will prevent the hammer from operating. Failure to tighten the clamp fittings completely tight will cause the control cylinder to operate erratically. If this happens, the fittings may need to be cracked and the pressure bled off to release the quick disconnects.

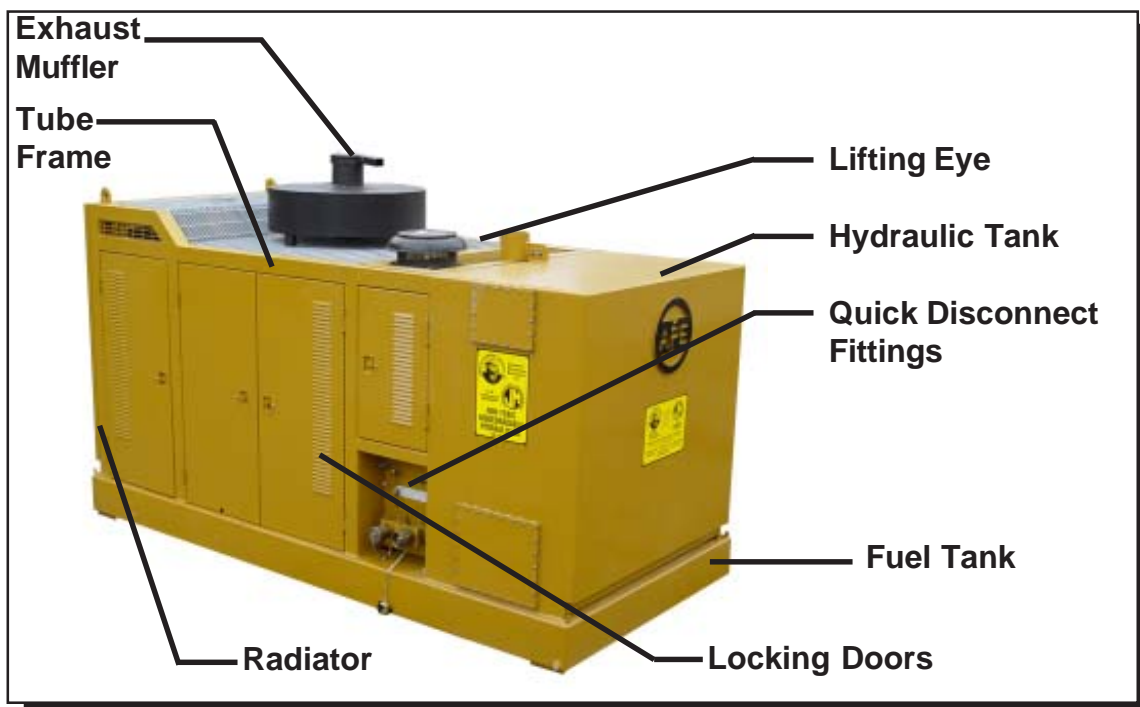

**Figure 1-G. General Description of Model 1000 Power Unit**



# OPERATION / MAINTENANCE MANUAL

MODEL 400 HYDRAULIC IMPACT HAMMER

7032 SOUTH 196th - KENT, WA 98032 - (800) 248-8498 / FAX (253) 872-8710

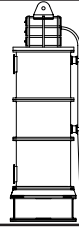

## II. PREPARING THE 400 HAMMER

### II-1. Assembling the HIH 400

The HIH 400 will be shipped with the ram in the main housing, the stroke control system intact, the primary plumbing in place, and the accumulators fully charged. Due to weight, large sub-assemblies are shipped separately. The striker plate will normally be shipped within its housing, with the transition section bolted up. It will need to be set up on the bell housing, and will need to be bolted onto the main hammer. Hydraulics will need to be plumbed to the power unit and to the visual stroke indicator.

1. Place bell housing vertically and securely onto level surface.
2. Place striker plate housing vertically and securely onto level surface.
3. Lift striker plate with housing onto bell housing.
4. Bolt bell housing to striker plate housing, using new stover nuts.
5. Lift the hammer onto the striker plate / bell assembly. Bolt together. Lift hammer and set into the cradle. **See figure 2-D.**
6. Connect the hoses per the diagrams. Make sure hoses are tight.
7. Inspect the hydraulic manifolds and control valve. Make sure all hoses are tight, and that there are no leaks.
8. Check the bolts on the top retainer plate (above the cylinder head) **See figure 2-E.** This ensures that the main cylinder will remain securely in place during driving.
9. Inspect & adjust the stroke control system.
  - a. Make sure the cable is tight, the hydraulic stroke control cylinder is secure, and that there are no oil leaks.
  - b. Make sure that the sled is not bound, and will travel freely in the guide rails.
  - c. Make sure the pulleys are aligned and secure.
  - d. Push the swing arm fully; have an assistant inspect the cam and trip valve at the top of the hammer. The plunger of the trip valve should push in 0.25" to 0.44" from extended. **See figure 2-B.**
10. Perform an overall visual inspection for loose parts, bolts, hoses & leaks.
11. Bleed the stroke control system per the instructions.
12. Bleed the main system only if necessary, with the hammer set vertically upon the pile.



# OPERATION / MAINTENANCE MANUAL

MODEL 400 HYDRAULIC IMPACT HAMMER

7032 SOUTH 196th - KENT, WA 98032 - (800) 248-8498 / FAX (253) 872-8710

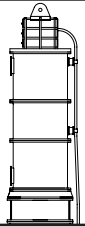

## II. PREPARING THE 400 HAMMER (Continued...)



**HAMMER w/ RAM  
(110,000 lb)**

**NEW 1-1/4"  
STOVER NUTS**



**STRIKER PLATE/  
HOUSING  
(20,000 lb)**



**BELL HOUSING  
(10,000 lb)**

**Figure 2-A. Lifting Main Cage & Cylinder onto Striker Plate / Bell**



# OPERATION / MAINTENANCE MANUAL

MODEL 400 HYDRAULIC IMPACT HAMMER

7032 SOUTH 196th - KENT, WA 98032 - (800) 248-8498 / FAX (253) 872-8710

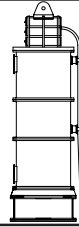

## II. PREPARING THE 400 HAMMER (Continued...)

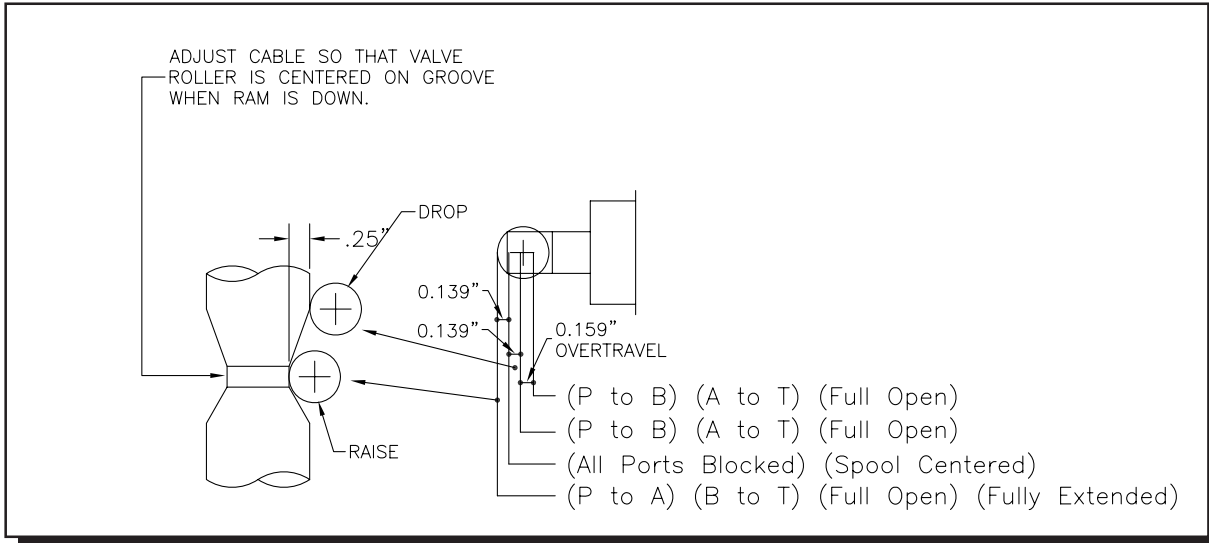

**Figure 2-B. Adjusting the Stroke Control Cam / Valve**

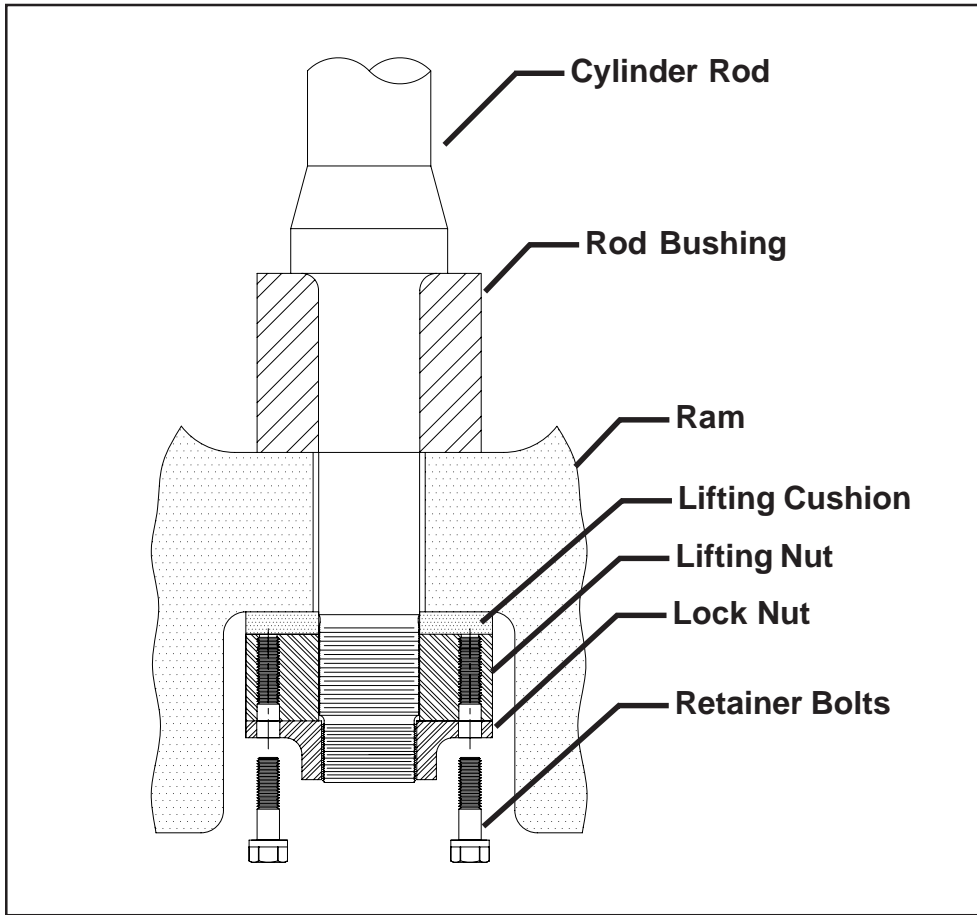

**Figure 2-C. Installing Lifting Cushion, Nuts & Bolts (Pre-installed)**

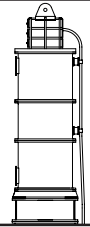

## II. PREPARING THE 400 HAMMER (Continued...)

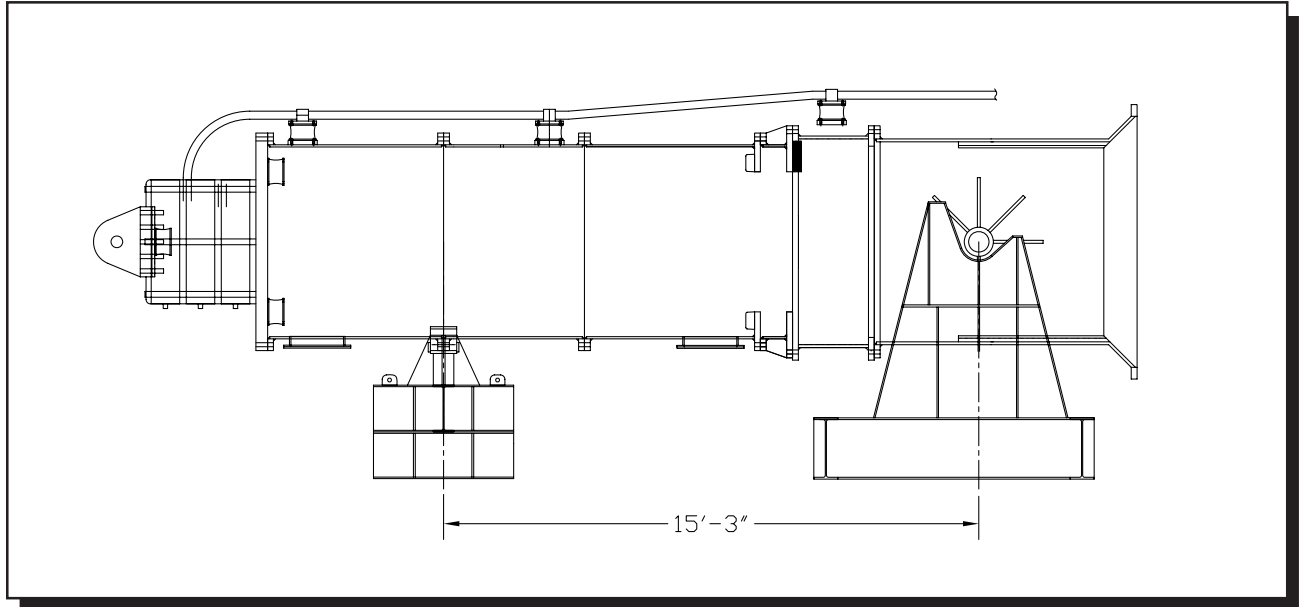

**Figure 2-D. Placing the Hammer in the Cradle**

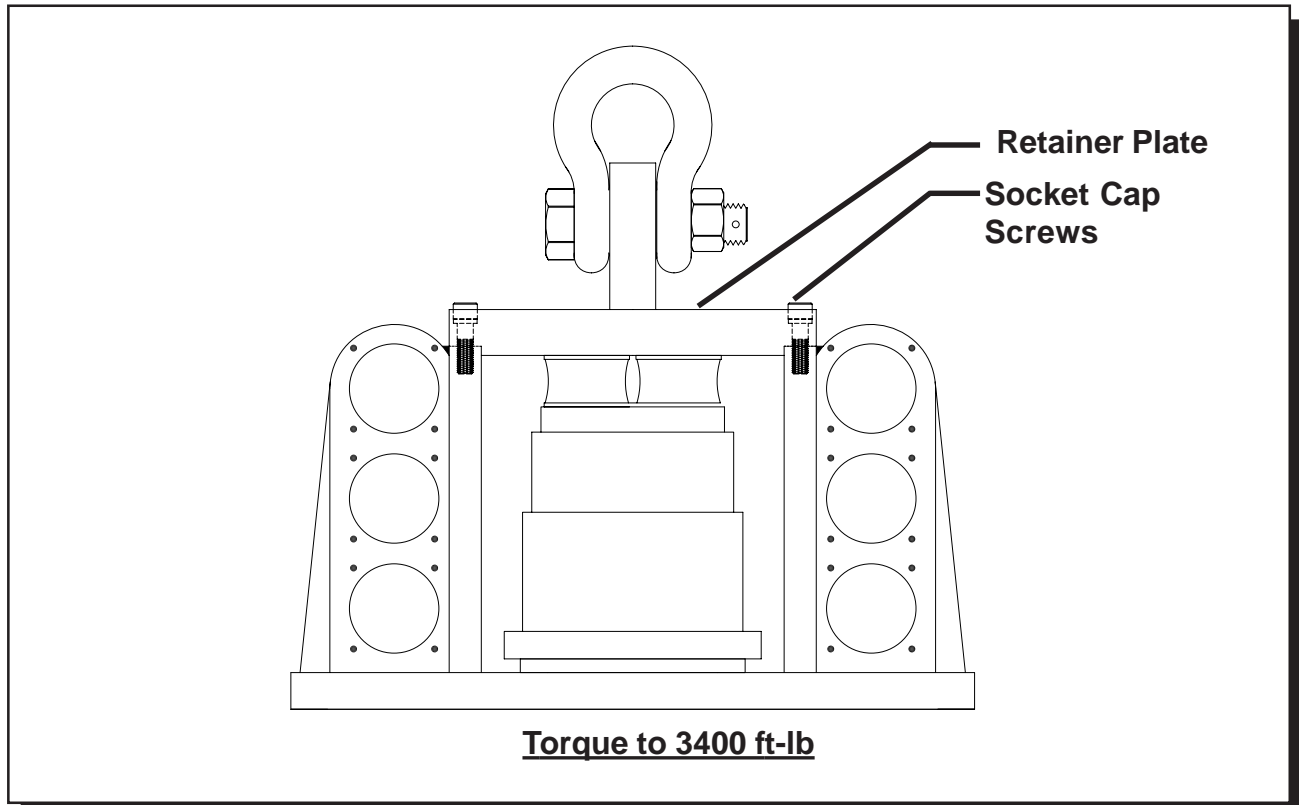

**Figure 2-E. Checking the Top Retainer Plate**



# OPERATION / MAINTENANCE MANUAL

MODEL 400 HYDRAULIC IMPACT HAMMER

7032 SOUTH 196th - KENT, WA 98032 - (800) 248-8498 / FAX (253) 872-8710

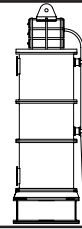

## II. PREPARING THE HAMMER (Continued...)

### II-2. Plumbing the Hoses to the Power Unit

There are four hoses leading from the vibro that must be connected to the power unit to begin operation. The hoses attach to the power unit by screwing the quick disconnect couplers onto the proper couplers of the power unit. The couplers on the power unit are mated with the couplers on the vibro so there is no chance of putting them on backwards. Please take the following steps when installing the couplers:

**WARNING: TURN THE POWER UNIT OFF BEFORE INSTALLING COUPLERS**

1. Turn the power unit OFF.
2. Clean all couplers with a can of ether if available. A clean dry cloth will also work but will require extreme care. Fittings must be spotless clean.
3. Install couplers by screwing them onto their respective counterparts. Try to avoid cross-threading and maintain a straight line. Jerk the hose back and forth while turning coupler to aid installation effort. **Push hard to get the big coupler threads started.**
4. Make sure fittings are tight. If they are properly cleaned they should run up tight with just a firm hand grip. However, they should be double checked with a chain wrench.
5. Avoid overtightening.
6. If near salt water, spray with a light oil to prevent oxidation.
7. Position the Power Unit so that vibrator has enough hose to reach the work. Avoid pulling too hard on hoses. Most hose failures are caused by pulling hoses off couplers.



**Figure 2-F. Power Unit Coupler Layout**



# **OPERATION / MAINTENANCE MANUAL**

MODEL 400 HYDRAULIC IMPACT HAMMER

7032 SOUTH 196th - KENT, WA 98032 - (800) 248-8498 / FAX (253) 872-8710

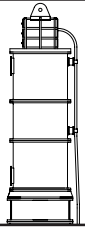

## **IV. PREPARING THE HAMMER (Continued...)**

### **II-3. Filling the Pressure Hose**

The HIH 400 is shipped with the hoses filled with oil. However, if the unit has been sitting for a long period of time or if a damaged hose has been replaced with a new one, then the hoses must be filled. Hook up all the hoses to the power unit. Start the power unit and let it run for ten minutes before running the hammer.

**WARNING: DO NOT BLEED SYSTEM AT FULL ENGINE THROTTLE BECAUSE TOO MUCH OIL WILL FLOW FROM THE HOSES AND COULD CAUSE INJURY.**





# OPERATION / MAINTENANCE MANUAL

MODEL 400 HYDRAULIC IMPACT HAMMER

7032 SOUTH 196th - KENT, WA 98032 - (800) 248-8498 / FAX (253) 872-8710

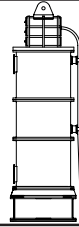

## II. PREPARING THE 400 HAMMER (Continued...)

### II-4. Setting up Stroke Control & Visual Indication System

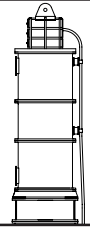

**Figure 2G. Visual Stroke Indicator Cylinder**



**Figure 2-H. Visual Stroke Indicator Cylinder - Rear**





### II. PREPARING THE 400 HAMMER (Continued...)

#### II-4. Setting up Stroke Control & Visual Indication System (Continued...)

1. Hook up hoses properly. **See figure 2-G, 2-H & 2-J.**
2. Turn both needle valves open, two turns from closed position.
3. Alternately cycle the system back and forth to fill the system.
4. Use Clamp-Close to retract the visual **Indicator Cylinder** & fully raise the stroke **Control Cylinder** (in hammer).
5. Close both needle valves.
6. Bleed the system.
  - a. Crack the "top" fitting at hammer, and cycle the cylinders back & forth a few inches. Tighten the fitting after all air is bled.
  - b. Use clamp-open to extend the visual **Indicator Cylinder** & fully lower the **Control cylinder**.
  - c. Crack the "bottom" fitting at hammer, and cycle the cylinders back & forth a few inches. Tighten the fitting after air is bled.
7. Cycle the cylinders to verify that each "gage foot" on the **Indicator Cylinder** corresponds to an actual foot on the **Control Cylinder**.
8. Perform a visual inspection to make sure that when the **Control Cylinder** in the hammer is fully down, the visual **Indicator Cylinder** reads 1.5 ft.
9. Also verify that when the **Control Cylinder** in the hammer is fully up, the visual **Indicator Cylinder** reads 6.0 ft.

Note: In order to verify that the system operates and indicates properly, measure the full stroke of the **Indicator Cylinder** with a tape measure. The full stroke of the **Indicator Cylinder** should be 14". The full stroke of the **Control Cylinder** should be 56".

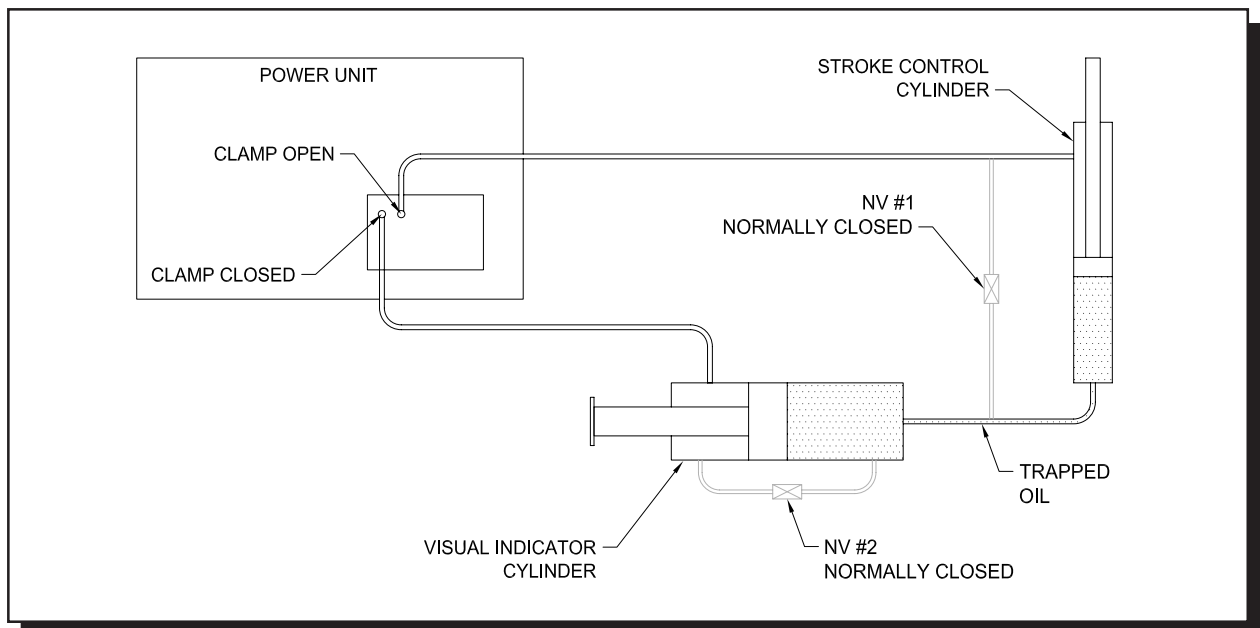

**Figure 2-J. Stroke Indicator & Control System Schematic**



# OPERATION / MAINTENANCE MANUAL

MODEL 400 HYDRAULIC IMPACT HAMMER

7032 SOUTH 196th - KENT, WA 98032 - (800) 248-8498 / FAX (253) 872-8710

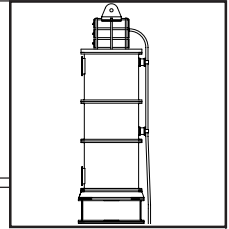

## III. RUNNING THE 400 HAMMER

### III-1. Selection of Control

The HIH 400 may be operated either using the "**LOCAL**" control (the control panel on the power unit), or the "**PENDANT**" control (the handheld unit). The **PENDANT** control is normally the preferred method of operation, as it allows the operator the greatest mobility. Regardless, the operator should position himself with an unobstructed view of the stroke indicator, hammer, crane and signal man.

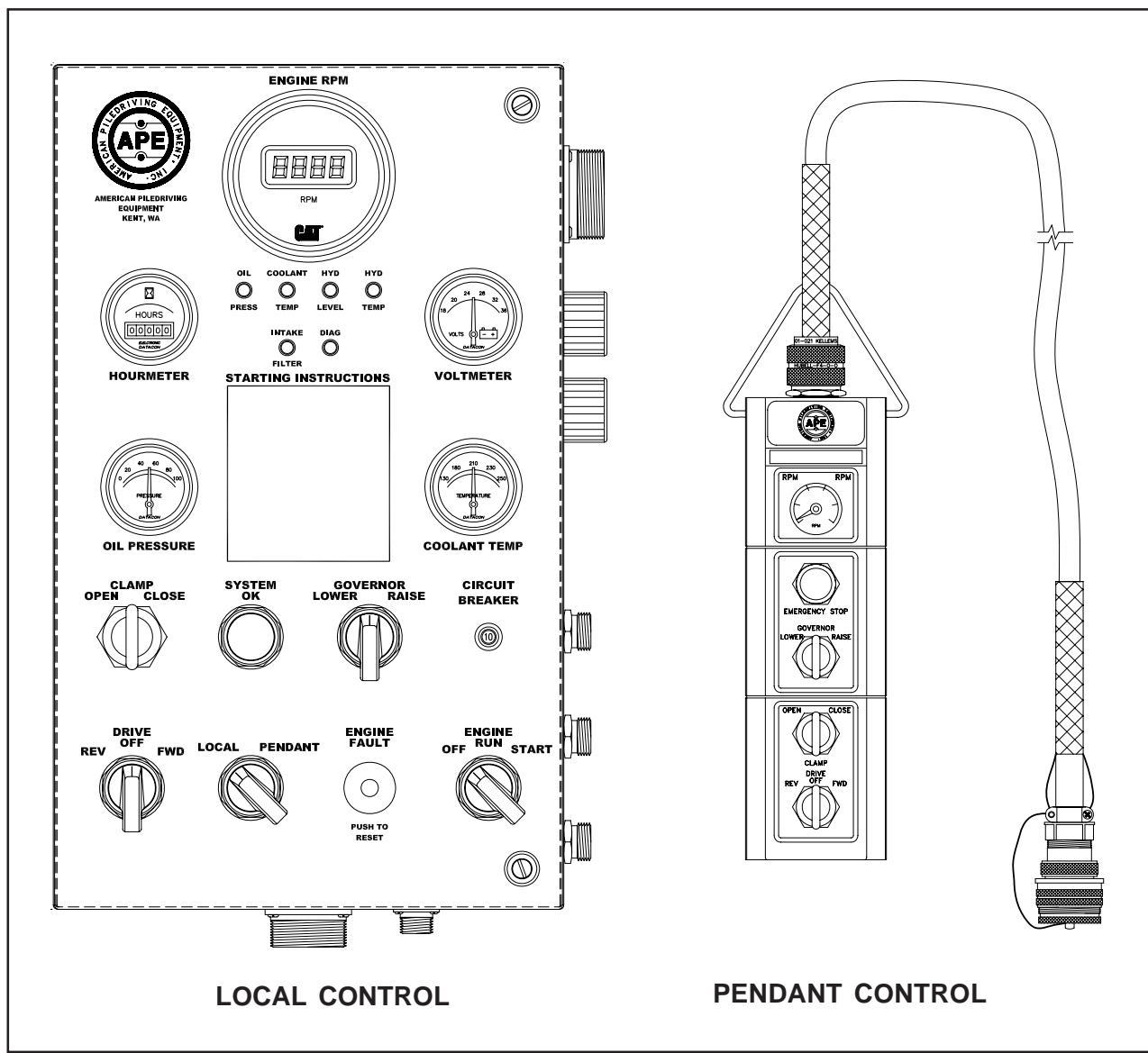

Figure 3-A. Selection of Control



# OPERATION / MAINTENANCE MANUAL

MODEL 400 HYDRAULIC IMPACT HAMMER

7032 SOUTH 196th - KENT, WA 98032 - (800) 248-8498 / FAX (253) 872-8710

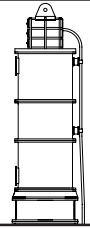

## III. RUNNING THE 400 HAMMER (Continued...)

### III-2. Procedure to Run Hammer - Stroke of 2.5 Feet or Less

1. Start and warm up power unit per procedure in power unit manual.
2. Decide whether to use **Local Panel** or **Pendant**.
3. Unload one pump by manually closing the valve inside the power unit.
4. Place hammer securely on pile. Striker plate should be loaded up against cushions. Lifting rigging should be slightly loose.
5. Set stroke to desired height using the **Clamp Open** or **Closed** switch. Use visual indicator to confirm stroke height.
6. Raise engine speed to 2000 RPM.
7. To operate hammer, turn **Drive Switch** to "FWD". (If using **Pendant**, turn **Drive Switch** to "UNLD".) Ram will raise and fall automatically. It will take a few cycles to achieve a consistent stroke, due to temperature effects of hydraulic oil.
8. **IMPORTANT** - Observe the pile. Crane operator must lower the hammer along with the pile, keeping the rigging slightly loose.
9. Increase or decrease the stroke as desired during driving, using the **Clamp Closed** or **Open** switch.
10. To stop hammer, turn **Drive Switch** to "OFF".
11. Lower engine speed to idle.
12. **IMPORTANT** – Power unit can be shut down immediately by turning **Engine Run** switch to "OFF" at panel, or pushing the red **Emergency Stop** button on the pendant.

### III-3. Procedure to Run Hammer - Stroke of More than 2.5 Feet (requires loading all pumps)

1. Make sure power unit has been warmed up.
2. Decide whether to use **Local Panel** or **Pendant**.
3. Load all pumps - manually open valves inside the power unit.
4. Make sure hammer is securely on pile, with striker plate loaded up against cushions. Lifting rigging should be slightly loose..
5. Set stroke to desired height using **Clamp Open** or **Closed** switch, and verify, using visual indicator.
6. Raise engine speed to 2100 RPM.
7. To start hammer, turn **Drive Switch** to "FWD". (If using **Pendant**, turn **Drive Switch** to "DRIVE FOR".) Ram will raise and fall automatically.
8. **IMPORTANT** - Observe the pile. Crane operator must lower the hammer along with the pile, keeping the rigging slightly loose.
9. Increase or decrease the stroke as desired during driving, using the **Clamp Closed** or **Open** switch.
10. To stop hammer, turn **Drive Switch** to "OFF".
11. Lower engine speed to idle.
12. **IMPORTANT** – Power unit can be shut down immediately by turning **Engine Run** switch to "OFF" at panel, or pushing the red **Emergency Stop** button on the pendant.



# OPERATION / MAINTENANCE MANUAL

MODEL 400 HYDRAULIC IMPACT HAMMER

7032 SOUTH 196th - KENT, WA 98032 - (800) 248-8498 / FAX (253) 872-8710

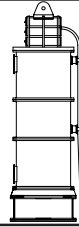

## III. RUNNING THE 400 HAMMER (Continued...)

### III-4. Shut-down Procedure

The following procedure explains how to correctly shut down the APE Model 400 Hammer and APE 1000 Power Unit.

1. Stop the hammer by turning "**DRIVE**" switch to **OFF**.
2. Allow the diesel engine to run for five minutes at 1000 engine rpm.
3. Reduce engine speed to low idle for about 60 seconds.
4. Shut engine off by turning off the main power switch.



# OPERATION / MAINTENANCE MANUAL

MODEL 400 HYDRAULIC IMPACT HAMMER

7032 SOUTH 196th - KENT, WA 98032 - (800) 248-8498 / FAX (253) 872-8710

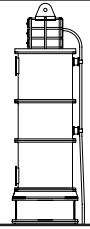

## IV. HYDRAULIC CIRCUIT

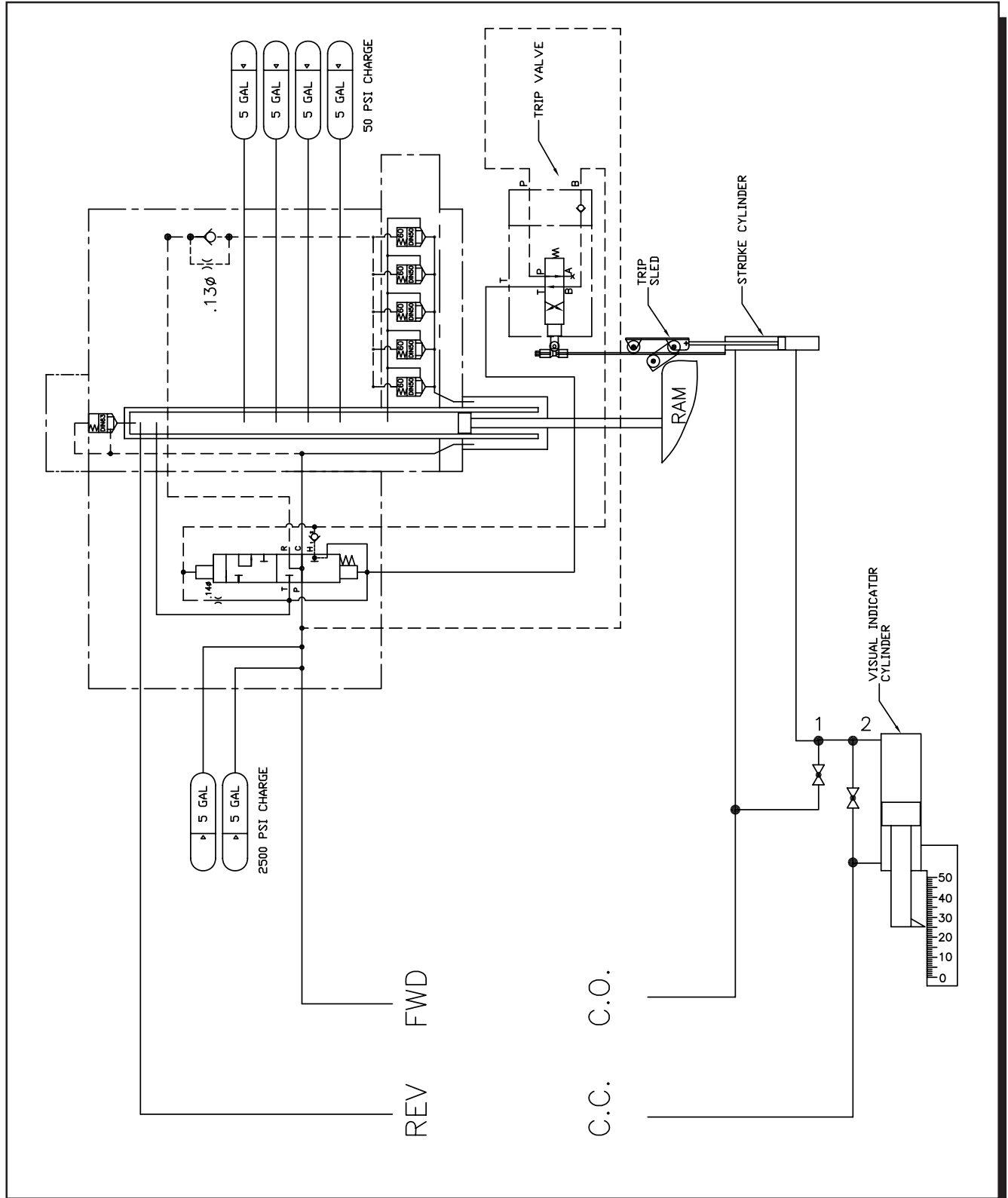

Figure 4-A. Hydraulic Circuit



# OPERATION / MAINTENANCE MANUAL

MODEL 400 HYDRAULIC IMPACT HAMMER

7032 SOUTH 196th - KENT, WA 98032 - (800) 248-8498 / FAX (253) 872-8710

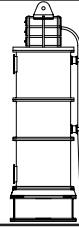

## V. PARTS LISTS

### V-1. Hammer Exterior

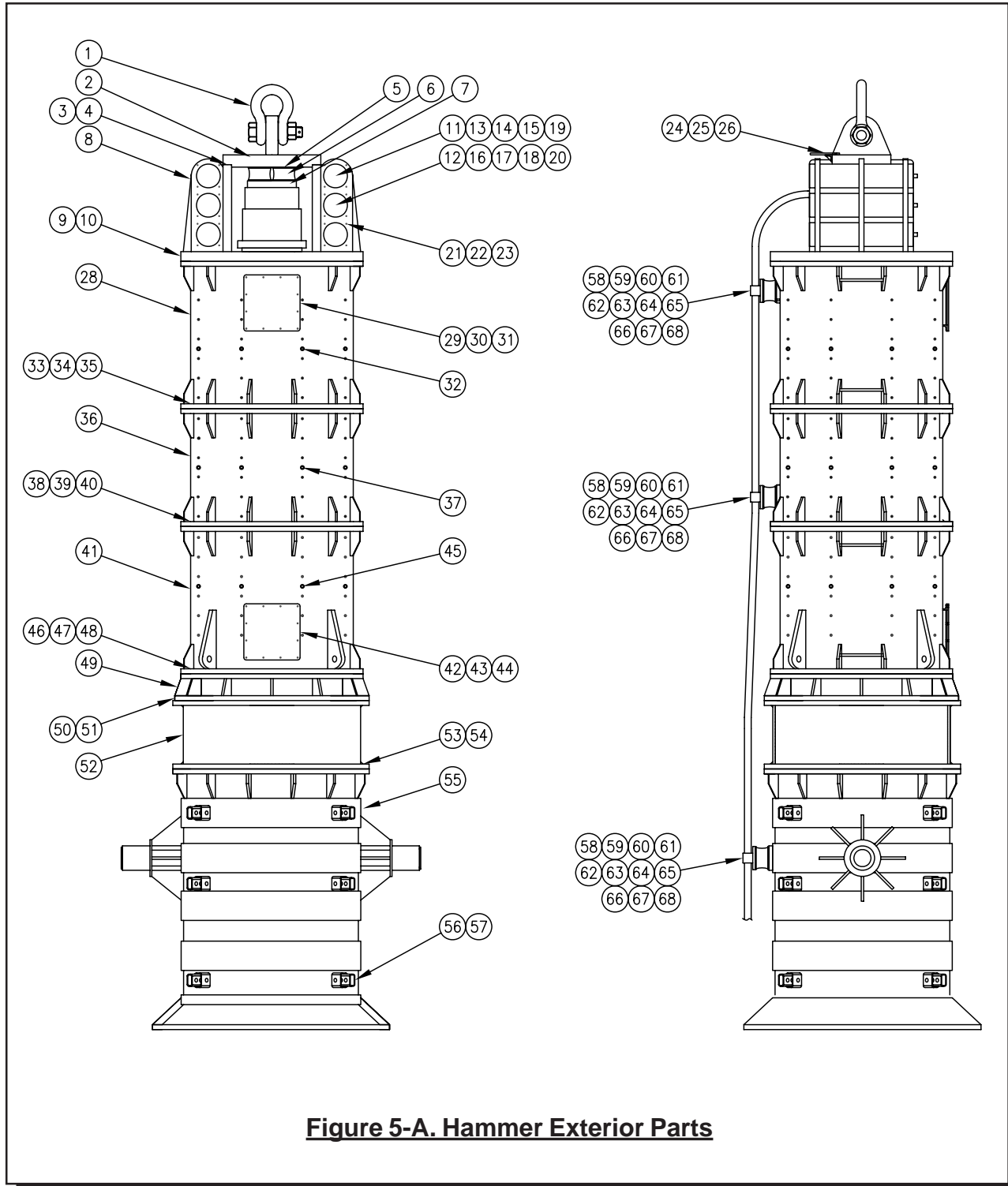

**Figure 5-A. Hammer Exterior Parts**



# OPERATION / MAINTENANCE MANUAL

MODEL 400 HYDRAULIC IMPACT HAMMER

7032 SOUTH 196th - KENT, WA 98032 - (800) 248-8498 / FAX (253) 872-8710

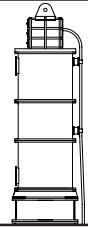

## V. PARTS LISTS (Continued...)

ITEM	P/N	QTY	DESCRIPTION	MFG. / VENDOR	DWG
1	G-2140	1	150 TON SHACKLE	CROSBY	---
2	B-1232	1	LIFTING PLATE	APE	B-1232
3	B-1232-1	10	1-3/4"-5 X 6.00 SHCS	HI-STRENGTH	---
4	B-1232-2	10	1-3/4" LOCK WASHER	HI-STRENGTH	---
5	A-1630	1	SPACER PLATE	APE	A-1630
6		2	ELASTOMER	APE	---
7	B-1287	1	VALVE MANIFOLD CAP	APE	B-1287
8	B-1231	1	TOP PLATE WELDMENT	APE	B-1233
9	B-1231-1	24	1-1/4"-7 X 8.00 GR 8 HEX BOLT	HI-STRENGTH	---
10	B-1231-2	24	1-1/4"-7 STOVER NUT	HI-STRENGTH	---
11	A7K1155C3KPP	2	5000 PSI ACCUMULATOR - 5 GAL	PARKER	---
12	A7K1155D3KPL	4	3000 PSI ACCUMULATOR - 5 GAL	PARKER	---
13	B-1234-1	4	HI PRESSURE PLATE NO. 1	APE	B-1234
14	B-1234-2	2	HI PRESSURE PLATE NO. 2	APE	B-1234
15	B-1234-3	4	HI PRESSURE SPACER	APE	B-1234
16	B-1234-4	8	LO PRESSURE PLATE NO. 1	APE	B-1234
17	B-1234-5	8	LO PRESSURE PLATE NO. 2	APE	B-1234
18	B-1234-6	8	LO PRESSURE SPACER	APE	B-1234
19	B-1257-1	16	.50 DIA 90 DURO URETHANE X 32.00	APE	B-1257
20	B-1257-2	32	.50 DIA 90 DURO URETHANE X 27.50	APE	B-1257
21	B-1257-3	48	5/8"-11 X 4.25 GR 8 HEX BOLT	HI-STRENGTH	---
22	B-1257-4	48	5/8" LOCK WASHER	HI-STRENGTH	---
23	B-1257-5	48	5/8"-11 STOVER NUT	HI-STRENGTH	---
24	A-1632	1	GUARD PLATE	APE	A-1632
25	A-1632-1	9	3/4"-10 SHCS	HI-STRENGTH	---
26	A-1632-2	9	3/4" LOCK WASHER	HI-STRENGTH	---
27	A-1600	1	TOP PLATE CUSHION	APE	A-1600
28	B-1235	1	TOP CAGE	APE	B-1238
29	B-1235-1	1	ACCESS HATCH COVER	APE	---
30	B-1235-2	12	3/4"-10 X 2.25 GR 8 HEX BOLT	HI-STRENGTH	---
31	B-1234-3	12	3/4"-10 STOVER NUT	HI-STRENGTH	---
32	B-1234-4	9	3/8 NPT BUTTON HEAD GREASE FITTING	ALEMITE	---
33	B-1234-5	2	1.25 DIA X 3.00 HARDENED DOWEL PIN	APE	---
34	B-1235-6	24	1-1/4"-7 X 6.50 GR 8 HEX BOLT	HI-STRENGTH	---
35	B-1235-7	24	1-1/4"-7 STOVER NUT	HI-STRENGTH	---
36	B-1236	1	CENTER CAGE	APE	B-1236
37	B-1236-2	8	3/8 NPT BUTTON HEAD GREASE FITTING	ALEMITE	---
38	B-1236-1	2	1.25 DIA X 3.00 HARDENED DOWEL PIN	APE	---
39	B-1236-3	24	1-1/4"-7 X 6.50 GR 8 HEX BOLT	HI-STRENGTH	---
40	B-1236-4	24	1-1/4"-7 STOVER NUT	HI-STRENGTH	---
41	B-1237	1	BOTTOM CAGE	APE	B-1237
42	B-1237-1	1	ACCESS HATCH COVER	APE	---
43	B-1237-2	12	3/4"-10 X 2.25 GR 8 HEX BOLT	HI-STRENGTH	---
44	B-1237-3	12	3/4"-10 STOVER NUT	HI-STRENGTH	---
45	B-1237-4	9	3/8 NPT BUTTON HEAD GREASE FITTING	ALEMITE	---
46	B-1237-5	2	1.25 DIA X 3.00 HARDENED DOWEL PIN	APE	---
47	B-1237-6	24	1-1/4"-7 X 6.50 GR 8 HEX BOLT	HI-STRENGTH	---
48	B-1237-7	24	1-1/4"-7 STOVER NUT	HI-STRENGTH	---
49	B-1240	1	TRANSITION SECTION	APE	---
50	B-1240-1	24	1-1/4"-7 X 6.50 GR 8 HEX BOLT	HI-STRENGTH	---
51	B-1240-2	24	1-1/4"-7 STOVER NUT	HI-STRENGTH	---
52	A-1610	1	STRIKER PLATE HOUSING	APE	A-1610
53	A-1610-1	24	1-1/4"-7 X 6.50 SHCS	HI-STRENGTH	---
54	A-1610-2	24	1-1/4"-7 STOVER NUT	HI-STRENGTH	---
55	A-1607	1	BELL HOUSING w/ TRUNNIONS	APE	A-1607
56	A-1607-1	4	ADJUSTABLE GUIDE	APE	A-1607-1
57	A-1607-2	8	PIN	APE	---
58	B-1250	3	HOSE CLAMP ASSEMBLY	APE	B-1250
59	321004	3	ELASTOMER	APE	---
60	B-1250-1	12	3/4"-10 X 2.50 GR 8 HEX BOLT	HI-STRENGTH	---
61	B-1250-2	12	3/4"-10 STOVER NUT	HI-STRENGTH	---
62	B-1250-3	3	BASE PLATE	APE	B-1250
63	B-1250-4	6	MAIN HOSE CLAMP	APE	B-1250
64	B-1250-5	12	7/8"-9 X 6.00 GR 8 HEX BOLT	HI-STRENGTH	---
65	B-1250-6	12	7/8"-9 STOVER NUT	HI-STRENGTH	---
66	A-1641	3	CONTROL HOSE CLAMP	APE	A-1641
67	A-1641-1	6	5/8"-11 X 3.50 GR 8 HEX BOLT	HI-STRENGTH	---
68	A-1641-2	6	5/8"-11 STOVER NUT	HI-STRENGTH	---



# OPERATION / MAINTENANCE MANUAL

MODEL 400 HYDRAULIC IMPACT HAMMER

7032 SOUTH 196th - KENT, WA 98032 - (800) 248-8498 / FAX (253) 872-8710

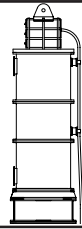

## V. PARTS LISTS (Continued...)

### V-2. Hammer Interior & Sub-Assemblies

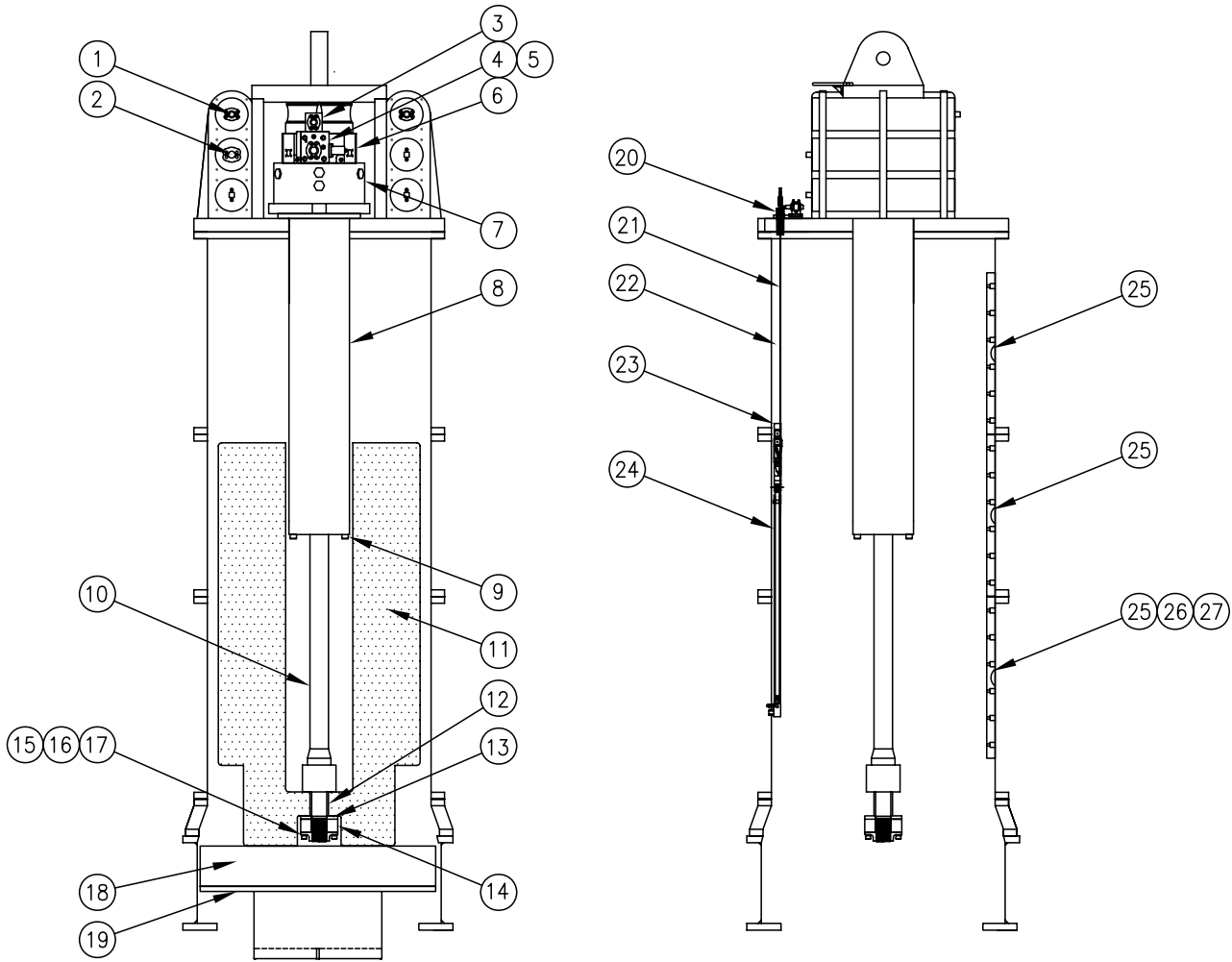

**Figure 5-B. Hammer Interior Parts & Sub-Assemblies**





# OPERATION / MAINTENANCE MANUAL

MODEL 400 HYDRAULIC IMPACT HAMMER

7032 SOUTH 196th - KENT, WA 98032 - (800) 248-8498 / FAX (253) 872-8710

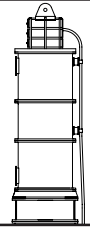

## V. PARTS LISTS (Continued...)

### V-2. Hammer Interior & Sub-Assemblies (Continued...)

**Table 5-B. Hammer Interior Parts & Sub-Assemblies**

ITEM	P/N	QTY	DESCRIPTION	MFG. / VENDOR	DWG
1	1902-24	5	1-1/2" CODE 62 SPLIT FLANGE KIT	BRENNAN	---
2	1901-32	9	2" CODE 61 SPLIT FLANGE KIT	BRENNAN	---
3	A-1635	1	HYDRAULIC FEED BLOCK	APE	A-1635
4	A-1622	1	SPOOL VALVE ASSEMBLY	APE	A-1622
5	A-1634	1	SANDWICH PLATE	APE	A-1634
6	A-1624	1	SECONDARY VALVE MANIFOLD	APE	A-1624
7	B-1246	1	CYLINDER VALVE BODY	APE	B-1246
8	A-1649	1	CYLINDER ASM	APE	A-1649
9	A-1649-1	24	1-1/4"-12 X 6.00 SHCS	HI-STRENGTH	---
10	B-1255	1	PISTON / ROD ASM	APE	B-1255
11	A-1650	1	RAM	APE	A-1650
12	A-1617	1	ROD BUSHING	APE	A-1617
13	A-1601	1	LIFTING CUSHION	APE	A-1601
14	B-1186-1	1	LIFTING NUT	APE	B-1186
15	B-1186-2	1	LOCK NUT	APE	B-1186
16	B-1186-3	12	1"-14 X 4.00 GR 8 HEX BOLT	HI-STRENGTH	B-1186
17	B-1186-4	12	1" HI-COLLAR LOCK WASHER	HI-STRENGTH	B-1186
18	A-1651	1	STRIKER PLATE	APE	A-1651
19	A-1647	1	ID GUIDE INSERT	APE	A-1647
20	B-1243	1	STROKE CONTROL VALVE ASM	APE	B-1243-1
21	B-1243-5	1	CABLE	APE	B-1243
22	B-1239-1	2	STROKE SLED GUIDE BEARING	APE	B-1239
23	B-1241	1	STROKE CONTROL SLED ASM	APE	B-1241
24	B-1242	1	STROKE CYLINDER ASM	APE	B-1242
25	B-1239-2	22	RAM BEARING	APE	B-1239
26	B-1239-3	152	5/8"-11 X 2.75 GR 8 HEX BOLT	HI-STRENGTH	---
27	B-1239-4	152	5/8" NYLOCK NUT	HI-STRENGTH	---

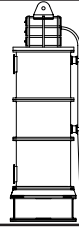

### V. PARTS LISTS (Continued...)

#### V-3. Spool Valve Assembly

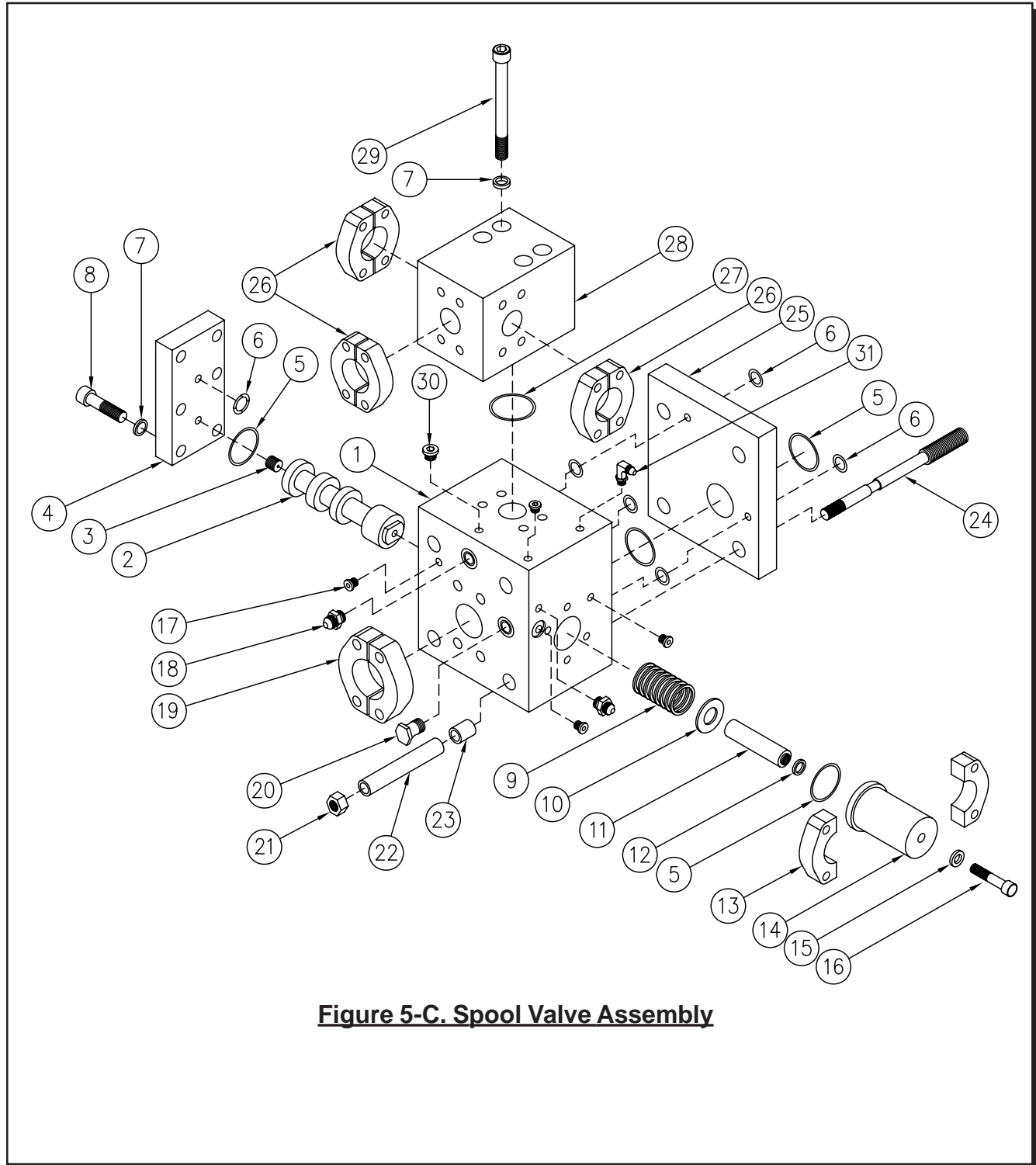

**Figure 5-C. Spool Valve Assembly**



# OPERATION / MAINTENANCE MANUAL

MODEL 400 HYDRAULIC IMPACT HAMMER

7032 SOUTH 196th - KENT, WA 98032 - (800) 248-8498 / FAX (253) 872-8710

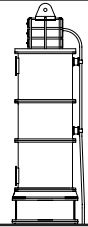

## V. PARTS LISTS (Continued...)

### V-3. Spool Valve Assembly (Continued...)

**Table 5-C. Spool Valve Assembly**

ITEM	P/N	QTY	DESCRIPTION	MFG. / VENDOR	DWG
1	B-1284	1	SPOOL VALVE BODY	APE	B-1284
2	160603	2	SPOOL	J&M	160603
3	160604	1	SAE #6 PLUG w/ 0.141" ORIFICE DRILL	J&M	---
4	A-1626	1	SPOOL VALVE CAP	APE	A-1626
5	<b>BIN STOCK</b>	1	<b>O-RING 2-228</b>	<b>PARKER</b>	---
6	<b>BIN STOCK</b>	6	<b>O-RING 2-210</b>	<b>PARKER</b>	---
7	<b>BIN STOCK</b>	10	<b>5/8" HI-COLLAR LOCK WASHER</b>	<b>HI-STRENGTH</b>	---
8	<b>BIN STOCK</b>	6	<b>5/8"-11 X 2.50 SHCS</b>	<b>HI-STRENGTH</b>	---
9	160809	1	SPRING	J&M	---
10	<b>BIN STOCK</b>	1	<b>1" WASHER</b>	<b>HI-STRENGTH</b>	---
11	160599	1	SPOOL STOP	J&M	160599
12	<b>BIN STOCK</b>	1	<b>O-RING 2-208</b>	<b>PARKER</b>	---
13	1901-32	1	2" CODE 61 SPLIT FLANGE KIT	BRENNAN	---
14	160597	1	SPRING CAP	J&M	160597
15	<b>BIN STOCK</b>	1	<b>1/2" STD. WASHER</b>	<b>HI-STRENGTH</b>	---
16	<b>BIN STOCK</b>	1	<b>1/2"-13 X 1.50 SHCS</b>	<b>HI-STRENGTH</b>	---
17	<b>BIN STOCK</b>	4	<b>#6 SAE FLUSH PLUG</b>	<b>PAC. RUBBER</b>	---
18	<b>BIN STOCK</b>	2	<b>#6 SAE X #6 JIC</b>	<b>PAC. RUBBER</b>	---
19	1902-32	1	2" CODE 62 SPLIT FLANGE KIT	BRENNAN	---
20	160323	1	CHECK VALVE	J&M	---
21	<b>BIN STOCK</b>	4	<b>5/8"-18 STOVER NUT</b>	<b>HI-STRENGTH</b>	---
22	A-1651	4	SLEEVE	APE	A-1651
23	A-1652	4	SPACER	APE	A-1652
24	A-1653	4	STEP STUD	APE	A-1653
25	A-1634	1	SANDWICH PLATE	APE	A-1634
26	1902-24	3	1.5" CODE 62 SPLIT FLANGE KIT	APE	---
27	<b>BIN STOCK</b>	1	<b>O-RING 2-225</b>	<b>PARKER</b>	---
28	A-1635	1	FEED BLOCK	APE	A-1635
29	<b>BIN STOCK</b>	4	<b>5/8"-11 X 6.50 SHCS</b>	<b>HI-STRENGTH</b>	---
30	<b>BIN STOCK</b>	1	<b>#8 SAE FLUSH PLUG</b>	<b>PAC. RUBBER</b>	---
31	<b>BIN STOCK</b>	1	<b>#6 SAE X #6 JIC - 90 DEG.</b>	<b>PAC. RUBBER</b>	---

NOTE: ALL SPLIT FLANGE KITS INCLUDE BOLTS AND LOCK WASHERS

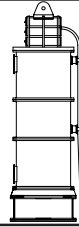

### V. PARTS LISTS (Continued...)

#### V-4. Secondary Valve Manifold Assembly

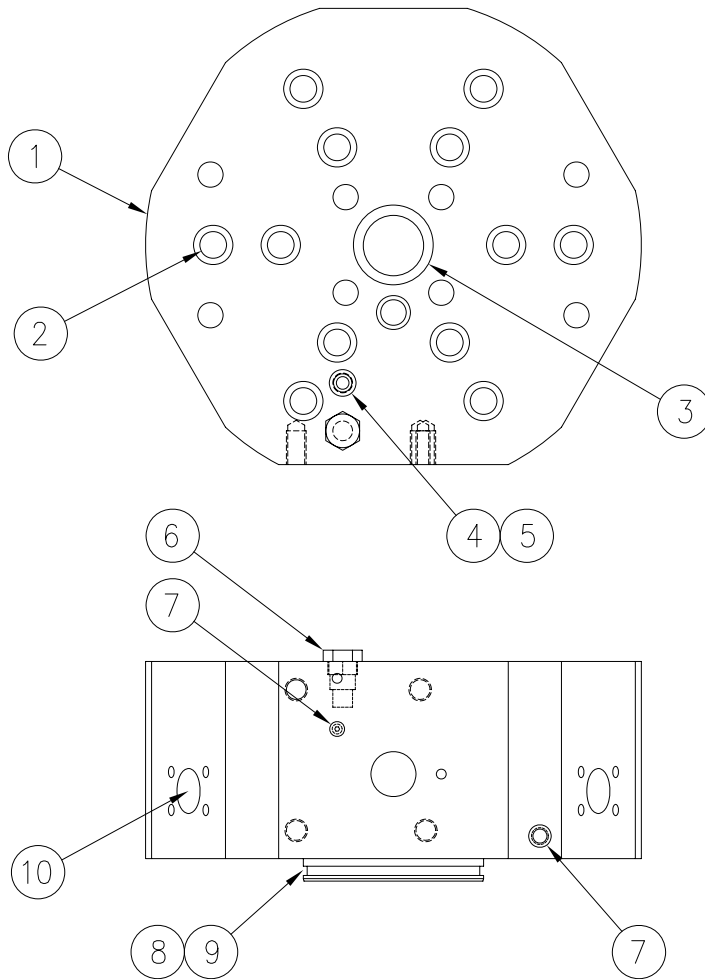

**Figure 5-D. Secondary Valve Assembly**

ITEM	P/N	QTY	DESCRIPTION	MFG. / VENDOR	DWG
1	A-1624	1	SECONDARY VALVE MANIFOLD	APE	A-1624
2	VENDOR STOCK	12	1-1/8-12 X 9.00 SHCS	HI-STRENGTH	---
3	CE-050-C-04-NOON	1	DIN 50 CARTRIDGE	HYDROLUX	3201e001.pdf
4	A-1624-1	1	#6 SAE PLUG w/ 1/8" DIA HOLE	APE	---
5	BIN STOCK	1	#16 SAE PLUG	PACIFIC RUBBER	---
6	160323	1	CHECK VALVE	J&M	---
7	BIN STOCK	1	#6 SAE PLUG	PACIFIC RUBBER	---
8	2-367	1	O-RING	PARKER	---
9	8-367	1	BACKUP RING	PARKER	---
10	1901-32	2	2" CODE 61 SPLIT FLANGE KIT	BRENNAN	---

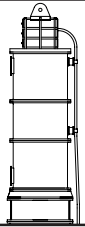

### V. PARTS LISTS (Continued...)

#### V-5. Primary Valve Manifold Assembly

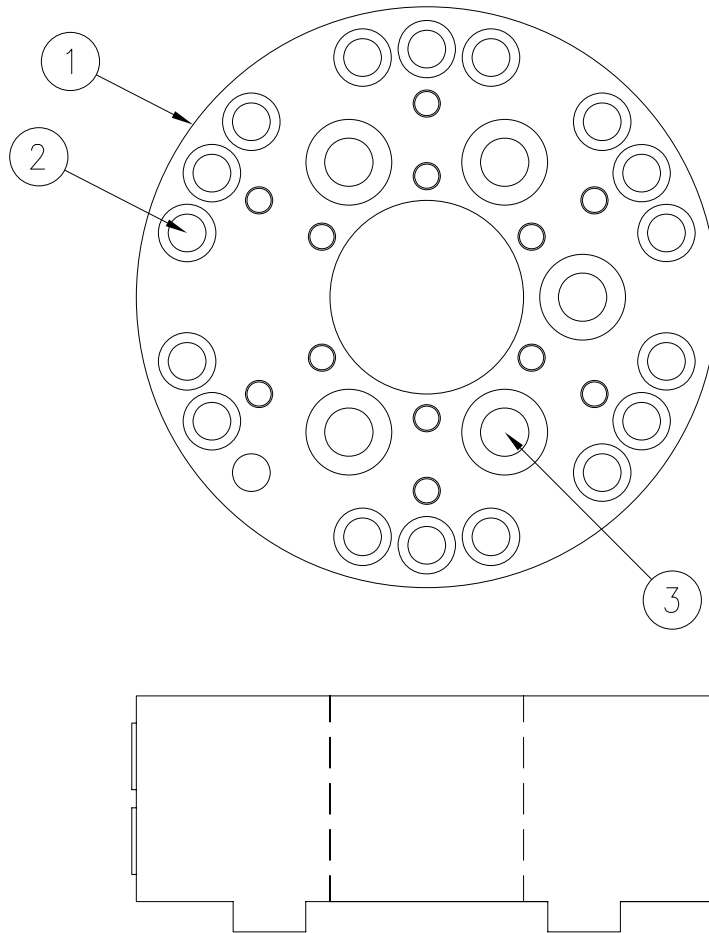

**Figure 5-E. Primary Valve Assembly**

ITEM	P/N	QTY	DESCRIPTION	MFG. / VENDOR	DWG
1	B-1246	1	PRIMARY VALVE MANIFOLD	APE	B-1246
2	VENDOR STOCK	18	1-1/2"-12 X 9.00 SHCS	HI-STRENGTH	- - -
3	CEE50B6BU/KOB	5	DIN 50 CARTRIDGE	HYDROLUX	3201e001.pdf



# OPERATION / MAINTENANCE MANUAL

MODEL 400 HYDRAULIC IMPACT HAMMER

7032 SOUTH 196th - KENT, WA 98032 - (800) 248-8498 / FAX (253) 872-8710

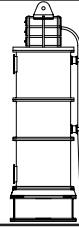

## V. PARTS LISTS (Continued...)

### V-6. Hydraulic Cylinder (Main)

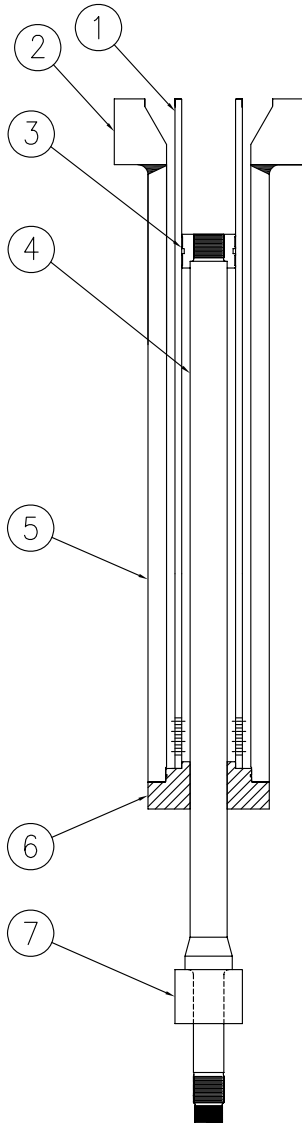

**Figure 5-F. Hydraulic Cylinder (Main)**

ITEM	P/N	QTY	DESCRIPTION	MFG. / VENDOR	DWG
1	A-1654	1	CYL. TUBE - INNER	APE	A-1654
2	A-1656	1	CYL. HEAD	APE	A-1656
3	B-1255-1	1	PISTON	APE	B-1255
4	B-1255-2	1	ROD	APE	B-1255
5	A-1656	1	GLAND	APE	A-1656
6	A-1655	1	CYL. TUBE - OUTER	APE	A-1655
7	B-1255-3	1	BUSHING	APE	B-1255

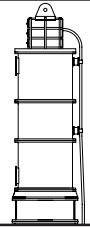

### V. PARTS LISTS (Continued...)

#### V-7. Trip Valve Assembly

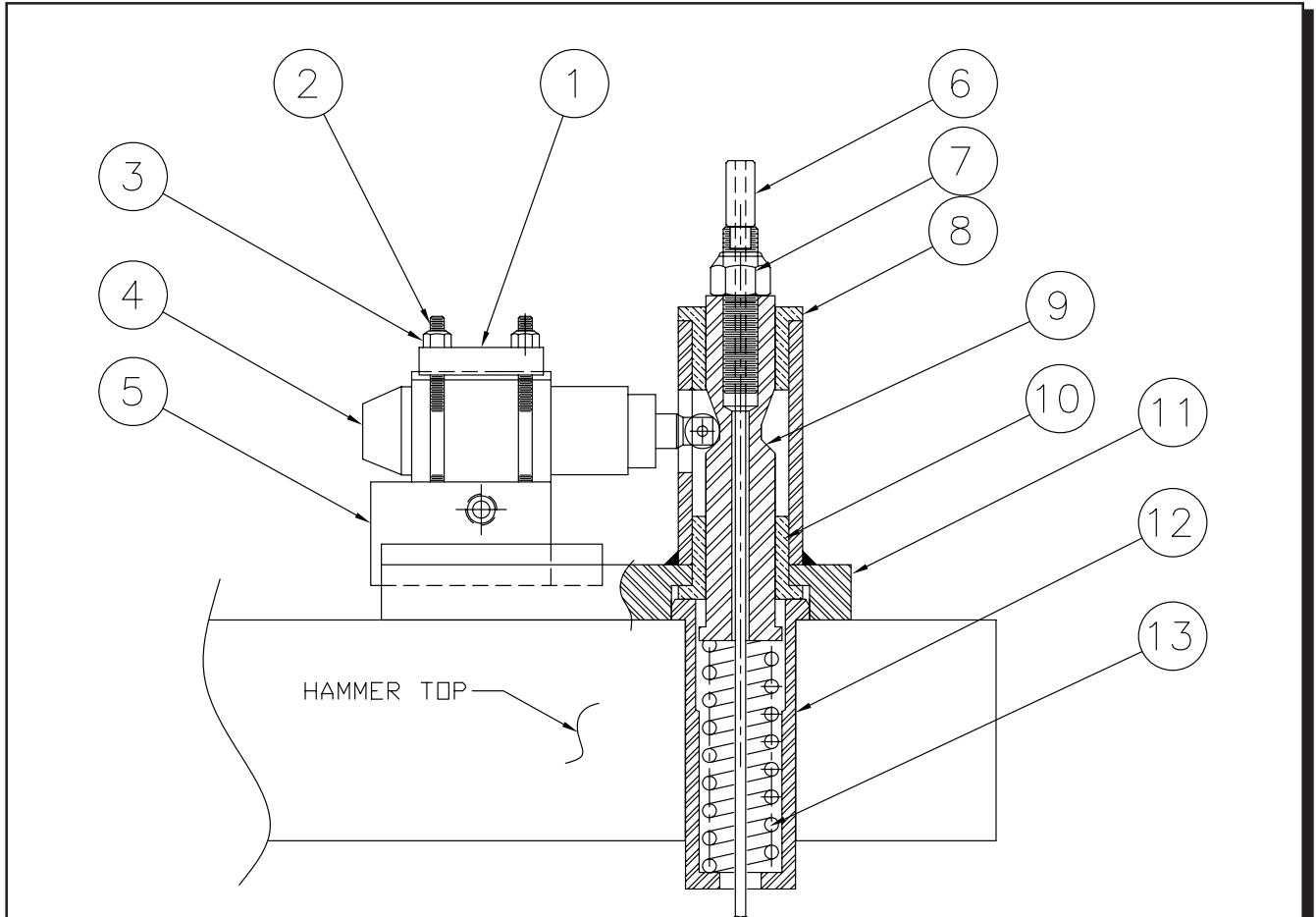

**Figure 5-G. Trip Valve Assembly**

ITEM	P/N	QTY	DESCRIPTION	MFG. / VENDOR	DWG
1	B-1243-4	1	VALVE RETAINER	APE	B-1243-4
2	<b>BIN STOCK</b>	4	<b>1/4"-20 X 3.50 B7 STUD</b>	<b>HI-STRENGTH</b>	---
3	<b>BIN STOCK</b>	4	<b>1/4"-20 NYLOCK NUT</b>	<b>HI-STRENGTH</b>	---
4	<b>D1VC1BNP05</b>	1	<b>DIRECTIONAL CONTROL VALVE</b>	<b>PARKER</b>	---
5	B-1243-3	1	SUB-PLATE	APE	B-1243-3
6	<b>B-1243-5A</b>	1	<b>1/4" CONTROL CABLE</b>	<b>WCWR</b>	<b>B-1243-5A</b>
7	B-1243-5B	1	ADJUSTING SLEEVE	APE	B-1243-5B
8	B-1243-2A	1	BUSHING	APE	B-1243-2A
9	B-1243-5C	1	PLUNGER (CAM)	APE	B-1243-5C
10	B-1243-2B	1	BUSHING	APE	B-1243-2B
11	B-1243-2C	1	BASE	APE	B-1243-2C
12	B-1243-4	1	SPRING CAGE	APE	B-1243-4
13	<b>9-2420-1</b>	1	<b>COMPRESSION SPRING</b>	<b>LEMPCO</b>	---

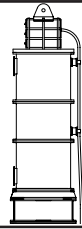

### V. PARTS LISTS (Continued...)

#### V-8 . Stroke Control Assembly

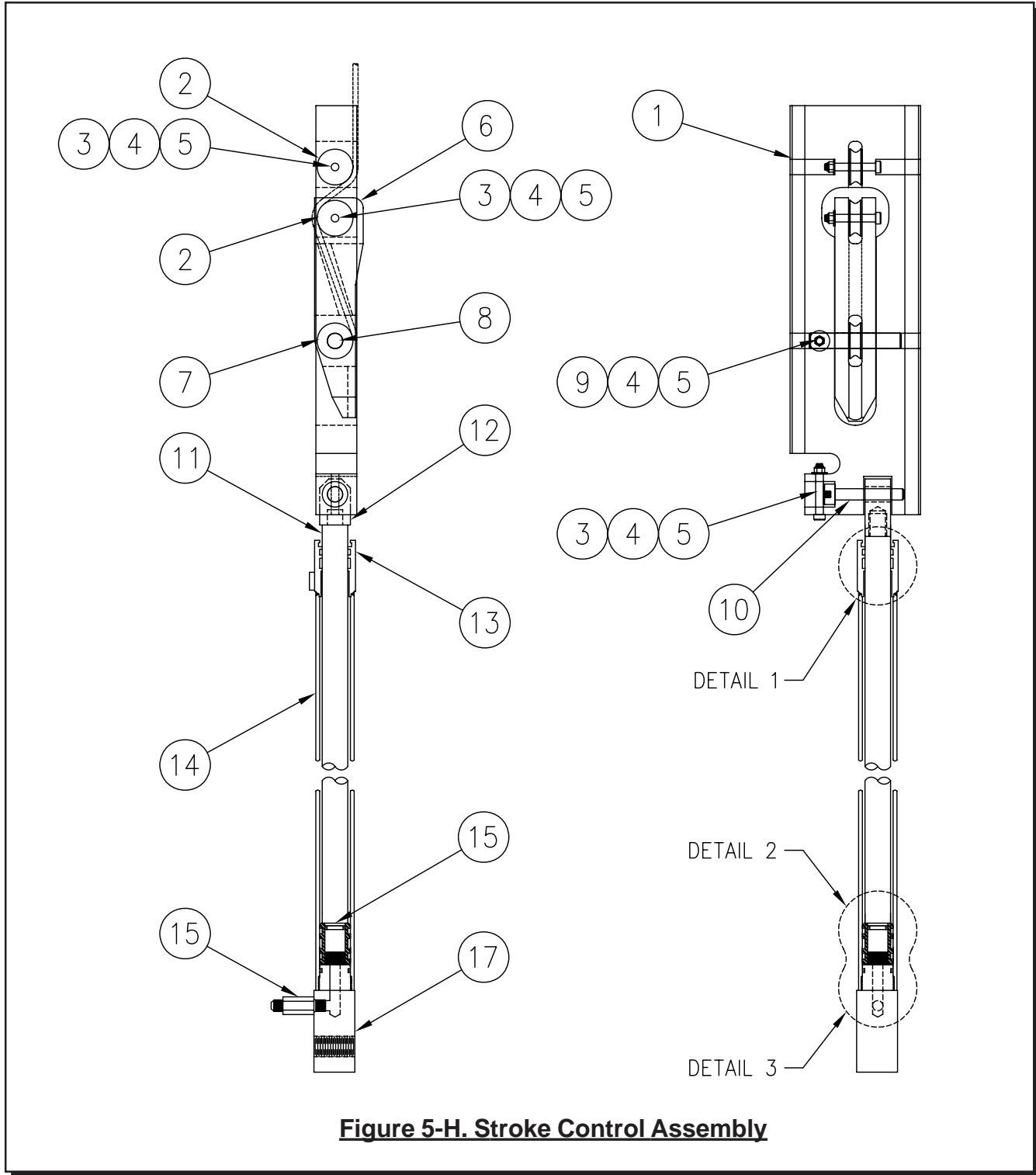

**Figure 5-H. Stroke Control Assembly**



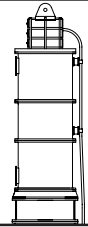

### V. PARTS LISTS (Continued...)

#### V-8 . Stroke Control Assembly (Continued...)

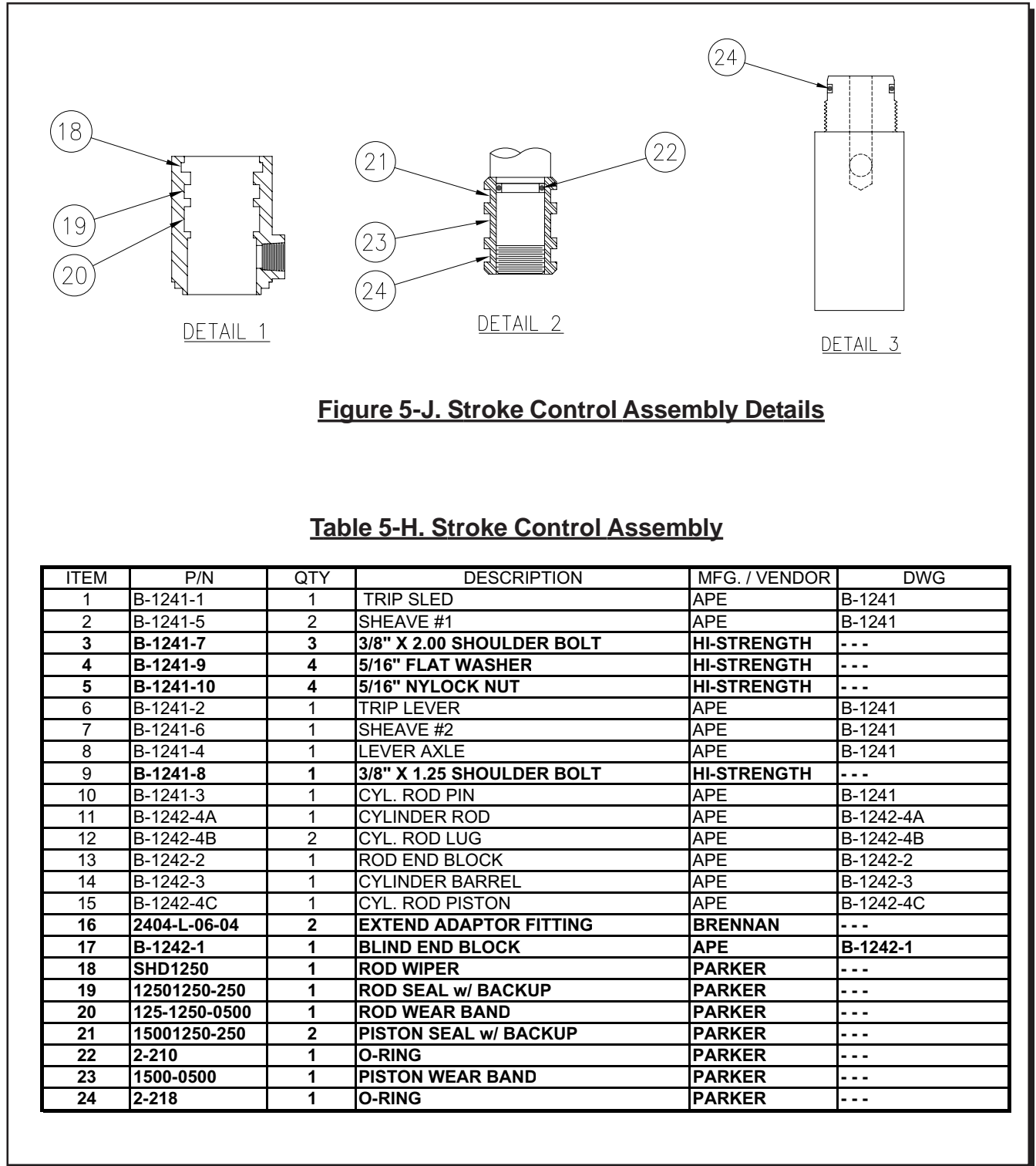

**Figure 5-J. Stroke Control Assembly Details**

**Table 5-H. Stroke Control Assembly**

ITEM	P/N	QTY	DESCRIPTION	MFG. / VENDOR	DWG
1	B-1241-1	1	TRIP SLED	APE	B-1241
2	B-1241-5	2	SHEAVE #1	APE	B-1241
3	<b>B-1241-7</b>	<b>3</b>	<b>3/8" X 2.00 SHOULDER BOLT</b>	<b>HI-STRENGTH</b>	<b>---</b>
4	<b>B-1241-9</b>	<b>4</b>	<b>5/16" FLAT WASHER</b>	<b>HI-STRENGTH</b>	<b>---</b>
5	<b>B-1241-10</b>	<b>4</b>	<b>5/16" NYLOCK NUT</b>	<b>HI-STRENGTH</b>	<b>---</b>
6	B-1241-2	1	TRIP LEVER	APE	B-1241
7	B-1241-6	1	SHEAVE #2	APE	B-1241
8	B-1241-4	1	LEVER AXLE	APE	B-1241
9	<b>B-1241-8</b>	<b>1</b>	<b>3/8" X 1.25 SHOULDER BOLT</b>	<b>HI-STRENGTH</b>	<b>---</b>
10	B-1241-3	1	CYL. ROD PIN	APE	B-1241
11	B-1242-4A	1	CYLINDER ROD	APE	B-1242-4A
12	B-1242-4B	2	CYL. ROD LUG	APE	B-1242-4B
13	B-1242-2	1	ROD END BLOCK	APE	B-1242-2
14	B-1242-3	1	CYLINDER BARREL	APE	B-1242-3
15	B-1242-4C	1	CYL. ROD PISTON	APE	B-1242-4C
16	<b>2404-L-06-04</b>	<b>2</b>	<b>EXTEND ADAPTOR FITTING</b>	<b>BRENNAN</b>	<b>---</b>
17	<b>B-1242-1</b>	<b>1</b>	<b>BLIND END BLOCK</b>	<b>APE</b>	<b>B-1242-1</b>
18	<b>SHD1250</b>	<b>1</b>	<b>ROD WIPER</b>	<b>PARKER</b>	<b>---</b>
19	<b>12501250-250</b>	<b>1</b>	<b>ROD SEAL w/ BACKUP</b>	<b>PARKER</b>	<b>---</b>
20	<b>125-1250-0500</b>	<b>1</b>	<b>ROD WEAR BAND</b>	<b>PARKER</b>	<b>---</b>
21	<b>15001250-250</b>	<b>2</b>	<b>PISTON SEAL w/ BACKUP</b>	<b>PARKER</b>	<b>---</b>
22	<b>2-210</b>	<b>1</b>	<b>O-RING</b>	<b>PARKER</b>	<b>---</b>
23	<b>1500-0500</b>	<b>1</b>	<b>PISTON WEAR BAND</b>	<b>PARKER</b>	<b>---</b>
24	<b>2-218</b>	<b>1</b>	<b>O-RING</b>	<b>PARKER</b>	<b>---</b>