



OPERATION AND MAINTENANCE MANUAL



SERIAL NUMBER:
H219

750U HYDRAULIC IMPACT HAMMER



OPERATION / MAINTENANCE MANUAL

MODEL 750U HYDRAULIC IMPACT HAMMER

7032 SOUTH 196th - KENT, WA 98032 - (800) 248-8498 / FAX (253) 872-8710

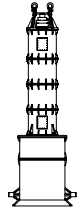

Preface

General

This manual covers the **Model 750U Hydraulic Impact Hammer**. The data provided in this manual gives the necessary information to operate and maintain this piece of APE equipment. The listed procedures are to be performed by qualified personnel who have an understanding of the equipment and who follow all safety precautions.

Guide to Using the Manual

1. Refer to the Table of Contents for the page location of applicable sections.
2. All weights and measurements in this manual are in both English and Metric units.
3. The manual will be revised as necessary to reflect current information.

Abbreviations

The following are abbreviations used within this manual.

lb	= Pounds	kg	= kilograms
psi	= Pounds per Square Inch	kW	= kilowatts
bar	= pressure (metric)	kip	= 1000 lbs
hp	= Horse Power	lpm	= liters per minute
gpm	= Gallons Per Minute	mm	= millimeters
rpm	= Revolutions Per Minute	T	=tons (US)
eng.	= Engine	t	= tonnes (metric)
cyl.	= Cylinder	m	= meters
mm	= Millimeter	S/N	= Serial Number
mtg.	= Mounting	P/N	= Part Number
sol.	= Solenoid	mfg.	= Manufacturer
adj.	= Adjustment	OD	= Outer Diameter
CW	= Clockwise	ID	= Inner Diameter
CCW	=Counter-Clockwise	ft	= feet



OPERATION / MAINTENANCE MANUAL

MODEL 750U HYDRAULIC IMPACT HAMMER

7032 SOUTH 196th - KENT, WA 98032 - (800) 248-8498 / FAX (253) 872-8710

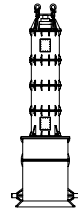

Table of Contents

	Page
Revision Record	i
Preface	ii
Table of Contents	iii
Safety Precautions	v
Illustration List	vi
Table List	vi
Warranty	vii
I. GENERAL INFORMATION	1-1
I-1. Machine Features	1-1
I-2. Machine Specifications	1-2
I-3. General Description of HIH 750	1-3
A. Lifting & Handling System	1-4
B. Ram / Main Cylinder	1-6
C. Stroke Control System	1-7
D. Striker Plate / Bell Housing	1-8
I-4. General Description of Model 1000 Power Unit	1-9
II. PREPARING THE HIH 40 HAMMER	2-1
II-1. Assembling the 750	2-1
II-2. Plumbing the Hoses to the Power Unit	2-5
ii-3. Filling the Pressure Hose	2-6
II-4. Setting up Stroke Control & Visual Indication System	2-7
III. RUNNING THE 750 HAMMER	3-1
III-1. Selection of Control	3-1
III-2. Procedure to Run Hammer - Stroke of 3 ft or Less	3-2
III-3. Procedure to Run Hammer - Stroke of More than 3 ft	3-2
III-4. Shut-down Procedure	3-3
IV. HYDRAULIC CIRCUIT	
IV-1. Circuit Diagram	4-1
V. PARTS LIST	
V-1. Hammer Exterior Parts	5-1
V-2. Hammer Interior Parts & Sub-Assemblies	5-3
V-3. Spool Valve Assembly	5-5
V-4. Secondary Valve Assembly	5-7
V-5. Primary Valve Assembly	5-8
V-6. Hydraulic Cylinder (Main)	5-9
V-7. Trip Valve Assembly	5-10
V-8. Stroke Control Assembly	5-11
V-9. DIN Bleed Check / Orifice	5-13
VI. MAINTENANCE / TROUBLESHOOTING	6-1



OPERATION / MAINTENANCE MANUAL

MODEL 750U HYDRAULIC IMPACT HAMMER

7032 SOUTH 196th - KENT, WA 98032 - (800) 248-8498 / FAX (253) 872-8710

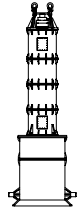

Table of Contents (Continued...)



OPERATION / MAINTENANCE MANUAL

MODEL 750U HYDRAULIC IMPACT HAMMER

7032 SOUTH 196th - KENT, WA 98032 - (800) 248-8498 / FAX (253) 872-8710

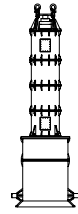

Safety Precautions

This list of precautions must be followed at all times to ensure personal & equipment safety.

1. Read this manual from beginning to end before operating or working on this machine.
2. When operating in a closed area, direct the exhaust fumes outside, using pipes. (**WARNING:** Breathing exhaust fumes can cause serious injury and even death.)
3. Assure that there is proper ventilation when charging batteries.
4. Never adjust or repair the unit while it is in operation.
5. Never enter hammer housing when power unit is running.
6. Make sure the Control Panel is in the "OFF" position before starting the unit.
7. Remove all tools and electrical cords before starting the power unit.
8. Keep oily rags away from the exhaust system.
9. Never store flammable liquids near the engine.
10. Never stand under impact hammer at any time. Keep your eyes on the hammer when it is in operation. Keep a look out for loose bolts or leaking hydraulic lines.
11. Avoid pulling on hose quick disconnect fittings. Move power unit closer to work if hoses cannot reach. Do not use hoses as a tow line to tug the power unit!
12. Avoid kinks in the hoses. Kinks will cut the hose safety factor by 50 percent.
13. Always wear ear protection.
14. Avoid standing downwind of piles during driving. Dirt and other matter may become airborne and fall into the unprotected eye.
15. Always wear a hardhat, gloves and safety shoes.
16. Always attach safety line to pile when extracting or hoisting into position.
17. Lay hammer down in cradle when not in use.
18. Do not transport power unit with quick disconnect caps and plugs screwed on to fittings unless the caps and plugs have wire rope safety lines attached. Store in storage box under control panel.
19. Follow the daily maintenance required prior to operation.
20. Follow the start-up procedures listed in the manual for the power unit being used.
21. Start with piles in good condition.
22. Keep piles plumb with pile guide(s).
23. Start slow. Come up to speed before doing hard driving.



OPERATION / MAINTENANCE MANUAL

MODEL 750U HYDRAULIC IMPACT HAMMER

7032 SOUTH 196th - KENT, WA 98032 - (800) 248-8498 / FAX (253) 872-8710

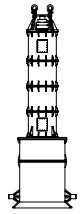

Illustration List

Figure	Title	Page
1-A.	Machine Features	1-1
1-B.	General Description of 750U Hammer	1-3
1-C.	General Description of Lifting & Handling	1-5
1-D.	General Description of Ram / Main Cylinder	1-6
1-E.	General Description of Stroke Control System	1-7
1-F.	General Description of Striker Plate / Bell Housing	1-8
1-G.	General Description of Model 1000 Power Unit	1-9
2-A.	Lifting Main Cage	2-2
2-B.	Adjusting Stroke Control Cam Valve	2-3
2-C.	Installing Lifting Cushions, Nuts & Bolts	2-3
2-D.	Placing the Hammer in the Cradle	2-4
2-E.	Checking the Top Retainer Plate	2-4
2-F.	Power Unit Coupler Layout	2-5
2-G.	Visual Stroke Indicator Cylinder	2-7
2-H.	Visual Stroke Indicator Cylinder	2-7
2-J.	Stroke Indicator & Control System Schematic	2-8
3-A.	Selection of Control	3-1
4-A.	Hydraulic Circuit	4-1
5-A.	Hammer Exterior Parts	5-1
5-B.	Hammer Interior Parts & Sub- Assemblies	5-3
5-C.	Spool Valve Assembly	5-5
5-D.	Primary Valve Assembly	5-7
5-E.	Secondary Valve Assembly	5-8
5-F.	Hydraulic Cylinder (Main)	5-9
5-G.	Trip Valve Assembly	5-10
5-H.	Stroke Control Assembly	5-11
5-J.	Stroke Control Assembly Details	5-12
5-K.	DIN Valve Bleed Check Valve / Orifice	5-13

Table List

Table	Title	Page
1-A	Model 750U Machine Specifications	1-2
5-A.	Hammer Exterior Parts List	5-2
5-B.	Hammer Interior & Sub Assemblies	5-4
5-C.	Spool Valve Assembly	5-6
5-D.	Primary Valve Assembly	5-7
5-E.	Secondary Valve Assembly	5-8
5-F.	Hydraulic Cylinder (Main)	5-9
5-G.	Trip Valve Assembly	5-10
5-H.	Stroke Control Assembly	5-12
5-K.	DIN Valve Bleed Check Valve / Orifice	5-13



OPERATION / MAINTENANCE MANUAL

MODEL 750U HYDRAULIC IMPACT HAMMER

7032 SOUTH 196th - KENT, WA 98032 - (800) 248-8498 / FAX (253) 872-8710

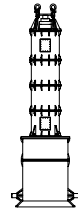

Warranty

American Piledriving Equipment, Inc. STANDARD WARRANTY

American Piledriving Equipment, Inc. (APE) warrants new products sold by it to be free from defects in material or workmanship for a period of one year after the date of delivery to the first user and subject to the following conditions:

APE's obligation and liability under this WARRANTY is expressly limited to repairing or replacing at APE's option, any parts which appear to APE upon inspection to have been defective in material or workmanship. Such parts shall be provided at no cost to the user, at the business establishment of APE or the authorized APE distributor of the product during regular working hours. **This WARRANTY, shall not apply to component parts or accessories of products not manufactured by APE** and which carry the warranty of the manufacturer thereof, or to normal maintenance (such as engine tune-up) or normal maintenance parts (such as filters). Replacement or repair parts installed in the product covered by this WARRANTY are warranted only for the remainder of the warranty as if such parts were original components of said product. AMERICAN PILEDIVING EQUIPMENT, INC. makes no other warranty, expressed or implied and makes no warranty of merchantability of fitness for any particular purpose.

APE's obligation under this WARRANTY shall not include any transportation charges, costs of installation, duty, taxes or any other charges whatsoever, or any liability for direct, indirect, incidental or consequential damage or delay. If requested by APE, products or parts for which a warranty claim is made are to be returned transportation prepaid to APE. Any improper use, including operation after discovery of defective or worn parts, operation beyond rated capacity, substitution of any parts whatsoever, or parts not approved by APE or any alteration or repair by others in such manner as in APE's judgment affects the product materially and adversely, shall void this warranty.

NO EMPLOYEE OR REPRESENTATIVE IS AUTHORIZED TO CHANGE THIS WARRANTY IN ANY WAY OR GRANT ANY OTHER WARRANTY UNLESS SUCH CHANGE IS MADE IN WRITING AND SIGNED BY AN OFFICER OF APE, INC.

**ANY TYPE OF WELDING ON EQUIPMENT
WILL VOID THE WARRANTY**

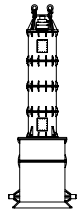

I. GENERAL INFORMATION

I-1. Machine Features - Model 750U Hydraulic Impact Hammer

High volume accumulators are placed close to lifting cylinder to enhance cycle rate.

Shorter than other hammers in its class, resulting in more headroom and reach.

Heavy duty lifting section with two 120 ton shackles and pins.

Double-cushioned head design isolates impact vibration from cylinder and external structure.

Ram is contained internally in steel housing. This protects the ram and control system, and eliminates guide rods and cables.

Hydraulic control spool valve has proven history of reliable operation, eliminating all electrical wires and electronic sensors.

Modular sections allow for custom breakdown for ease of shipping and interstate trucking.

Forged ram is low-headroom. Ram is bored to allow it to slide over lifting cylinder.

Internal ram guides are vertical and continuous, greasable from the outside.

Hydraulic cylinder operates on biodegradable vegetable oil, ensuring minimal environmental impact should a spill or leak occur.

Multiple access hatches are provided for access to control and lifting cylinders.

Lifting lugs are provided at bottom of hammer to allow for lifting options or support during battered driving operations.

Rebound cushions isolate impact forces from hammer when pile seats against the striker plate.

Bell housing is adjustable to allow for driving of several different pile sizes.

Striker plate is forged, and fully contained in a modular housing.

Heavy-duty trunions allow hammer to be rotated to horizontal position for storage and maintenance.

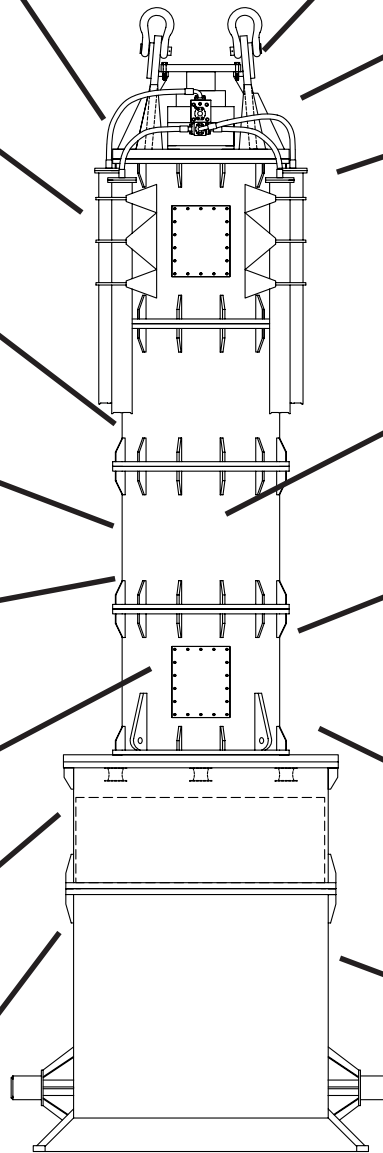

Figure 1-A. Machine Features



OPERATION / MAINTENANCE MANUAL

MODEL 750U HYDRAULIC IMPACT HAMMER

7032 SOUTH 196th - KENT, WA 98032 - (800) 248-8498 / FAX (253) 872-8710

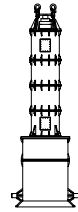

I. GENERAL INFORMATION (Continued...)

I-2. Model 750U Impact Hammer Specifications - (Table 1-A)

<u>Dimensional Data</u>	<u>Units (US)</u>		<u>Units (SI)</u>
Overall Height (Base to Hook)	40	ft	12.2 m
Bell Height	9.25	ft	2.82 m
Bell ID (Max Pile Diameter)	101.5	in	2.58 m
Striker Plate Housing Height	53.5	in	1.36 m
Striker Plate Housing OD	105.5	in	2.73 m
Striker Plate Height	36	in	0.91 m
Striker Plate Diameter	105	in	2.67 m
Cage Section Height	22.1	ft	6.72 m
Cage Max. OD	74.5	in	1.89 m
Ram Length	179.25	in	4.55 m
Ram Max. OD	60	in	1.52 m
<u>Weight Data</u>	<u>Units (US)</u>		<u>Units (SI)</u>
Overall Weight	280	kips	127.3 t
Striker Plate Weight	90	kips	40.9 t
Ram Weight	120	kips	54.5 t
<u>Performance Data</u>	<u>Units (US)</u>		<u>Units (SI)</u>
Maximum Stroke	6.25	ft	1.91 m
Minimum Stroke	1.50	ft	0.46 m
Maximum Calc. Energy	750,000	ft-lb	1017 kN-m
Minimum Calc. Energy	180,000	ft-lb	244 kN-m
Max. System Pressure	4500	psi	310 bar

**Dimensions may vary depending on the year and model.
 Consult the factory for certifications on unit being used.**



OPERATION / MAINTENANCE MANUAL

MODEL 750U HYDRAULIC IMPACT HAMMER

7032 SOUTH 196th - KENT, WA 98032 - (800) 248-8498 / FAX (253) 872-8710

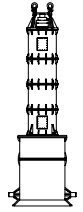

I. GENERAL INFORMATION (Continued...)

I-3. General Description of Model 750U Hydraulic Impact Hammer

The **APE Model 750U** is a variable stroke, hydraulically-operated and controlled pile driver. In addition, the hammer can be used for soil compaction, installing well casings and testing piers.

The Model 750U operates in a range of approximately 15 to 60 cycles per minute depending on the hydraulic flow and desired stroke. The Model 750U is especially suited for driving large diameter piles and caissons.

The four major parts to the Model 750U are as follows:

- A) The Lifting & Handling System / Cage
- B) The Ram / Main Cylinder
- C) The Stroke Control System
- D) The Striker Plate / Bell

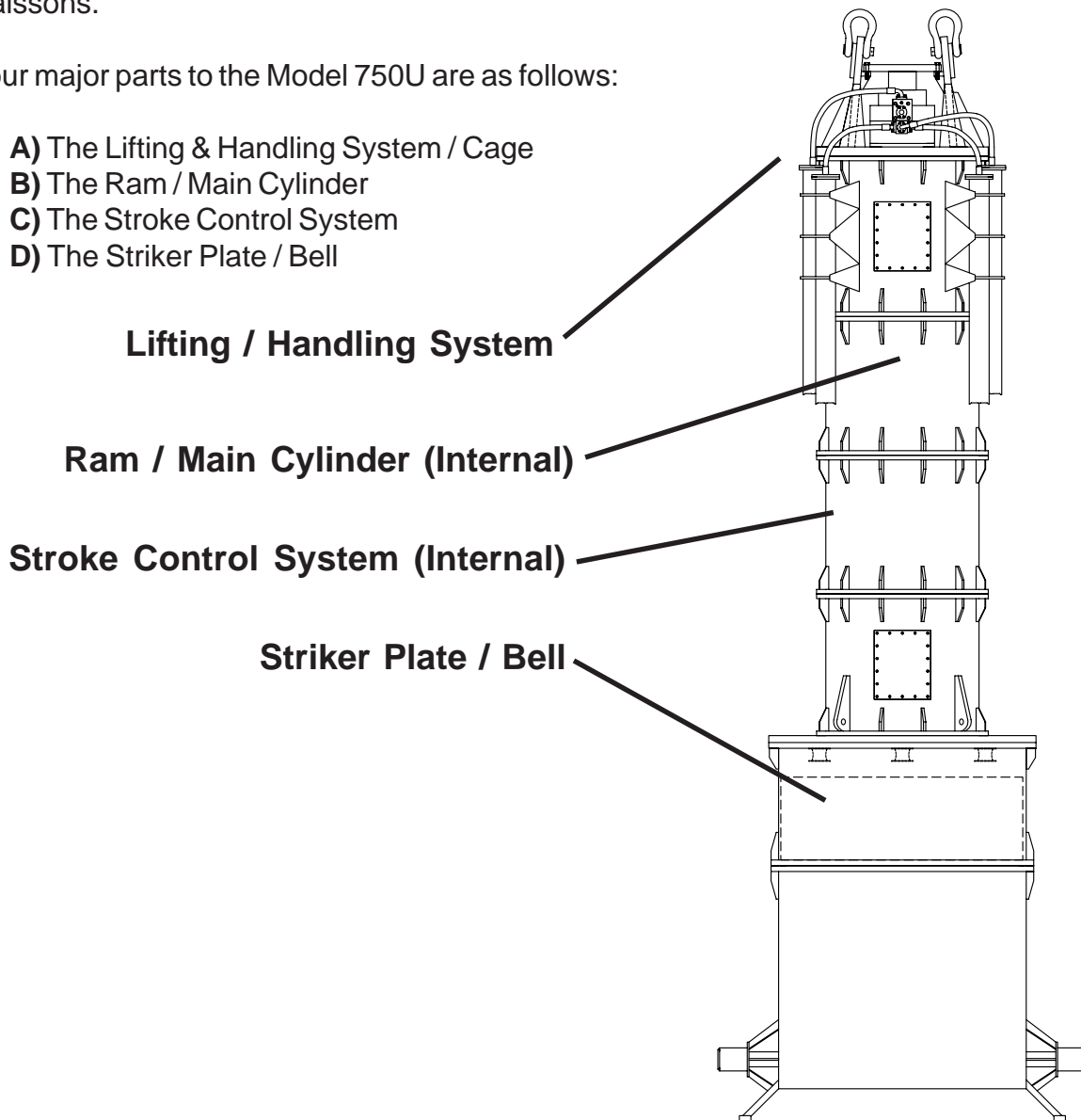

Figure 1-B. General Description of 750U Hammer



OPERATION / MAINTENANCE MANUAL

MODEL 750U HYDRAULIC IMPACT HAMMER

7032 SOUTH 196th - KENT, WA 98032 - (800) 248-8498 / FAX (253) 872-8710

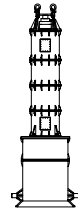

I. GENERAL INFORMATION (Continued...)

I-3A. The Lifting & Handling System / Cage Housing

The lifting system consists of two 120 ton (110 t) hooks, attached to an assembly of plates at the top of the hammer, which allows the full weight of the hammer to be lifted vertically and set on top of a pile. There are also lifting lugs at the bottom of the main cage to assist in alignment of the hammer if needed. The heavy duty trunnions at the base of the bell section permit the hammer to be set on a cradle and rotated to horizontal for storage and / or maintenance.

CAUTION!

DURING LIFTING:

The rigging from the crane to the hammer must be rated for the load of the full hammer weight plus any expected impact factor. The lifting must be conducted smoothly so as to minimize impact forces in the rigging.

DURING DRIVING:

When driving a pile, the crane operator must watch the rigging very carefully, and maintain a small amount of slack in the rigging. If there is no slack in the rigging during driving, the striker plate might not be fully seated. The ram will over-stroke and damage the hammer internally.

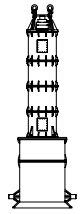

I. GENERAL INFORMATION (Continued...)

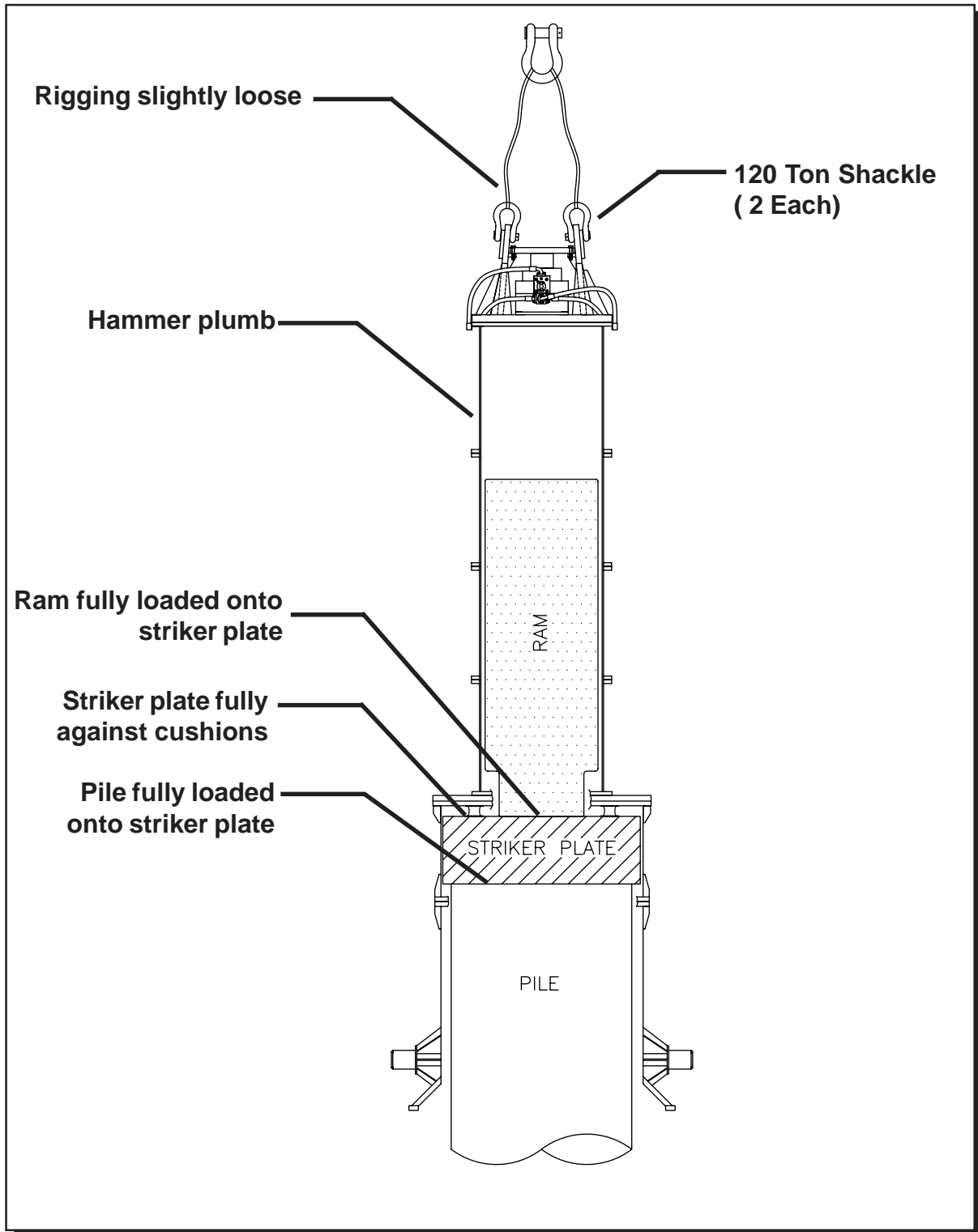

**Figure 1-C. General Description of Handling
 (Proper Position for Driving)**



OPERATION / MAINTENANCE MANUAL

MODEL 750U HYDRAULIC IMPACT HAMMER

7032 SOUTH 196th - KENT, WA 98032 - (800) 248-8498 / FAX (253) 872-8710

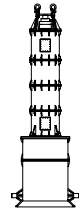

I. GENERAL INFORMATION (Continued...)

I-3B. Ram / Main Cylinder

Hydraulic oil is pumped from the power unit drive pumps (and assisted by the high-pressure accumulators) into the main cylinder, lifting the ram. The ram continues to rise to a point determined by the stroke control cylinder (see next section). At that point hydraulic oil flow to the main cylinder is cut off, and the ram is allowed to drop. The ram falls, and the impact of the ram (onto the striker plate) transmits energy to the pile. After the impact, the cycle is repeated automatically with no action required of the operator.

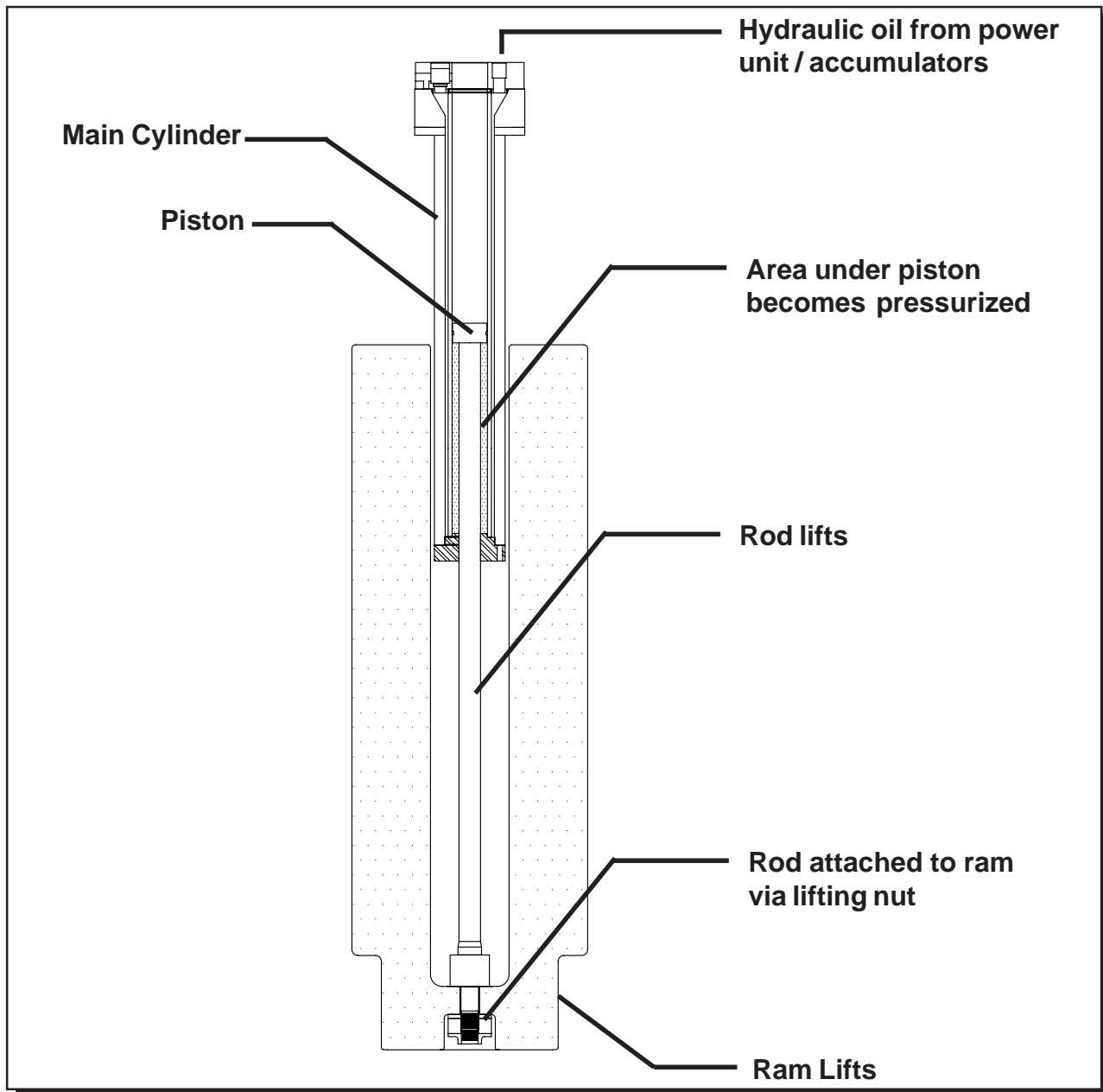
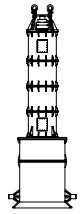

Figure 1-D. General Description of Ram / Main Cylinder



I. GENERAL INFORMATION (Continued...)

I-3C. Stroke Control System

The stroke control system pre-sets the stroke height of the ram, and is adjustable, either before, or during the operation of the hammer. The stroke control system consists of a small hydraulic cylinder, mounted inside the hammer cage, which is operated by the power unit clamp circuit. The cylinder raises and lowers a swing arm, which is connected to the cylinder rod. A mobile ground device is slaved to this rod, permitting the operator to see the desired stroke.

The swing arm is positioned in the path of the ram, such that the ram contacts the swing arm on each stroke. The swing arm then presses a cable, which actuates a cam at the top of the hammer. The cam depresses a plunger type directional valve, which in turn pilots the main control valve. Note that the cylinder is used for positioning the swing arm only, and is not under continuous operation.

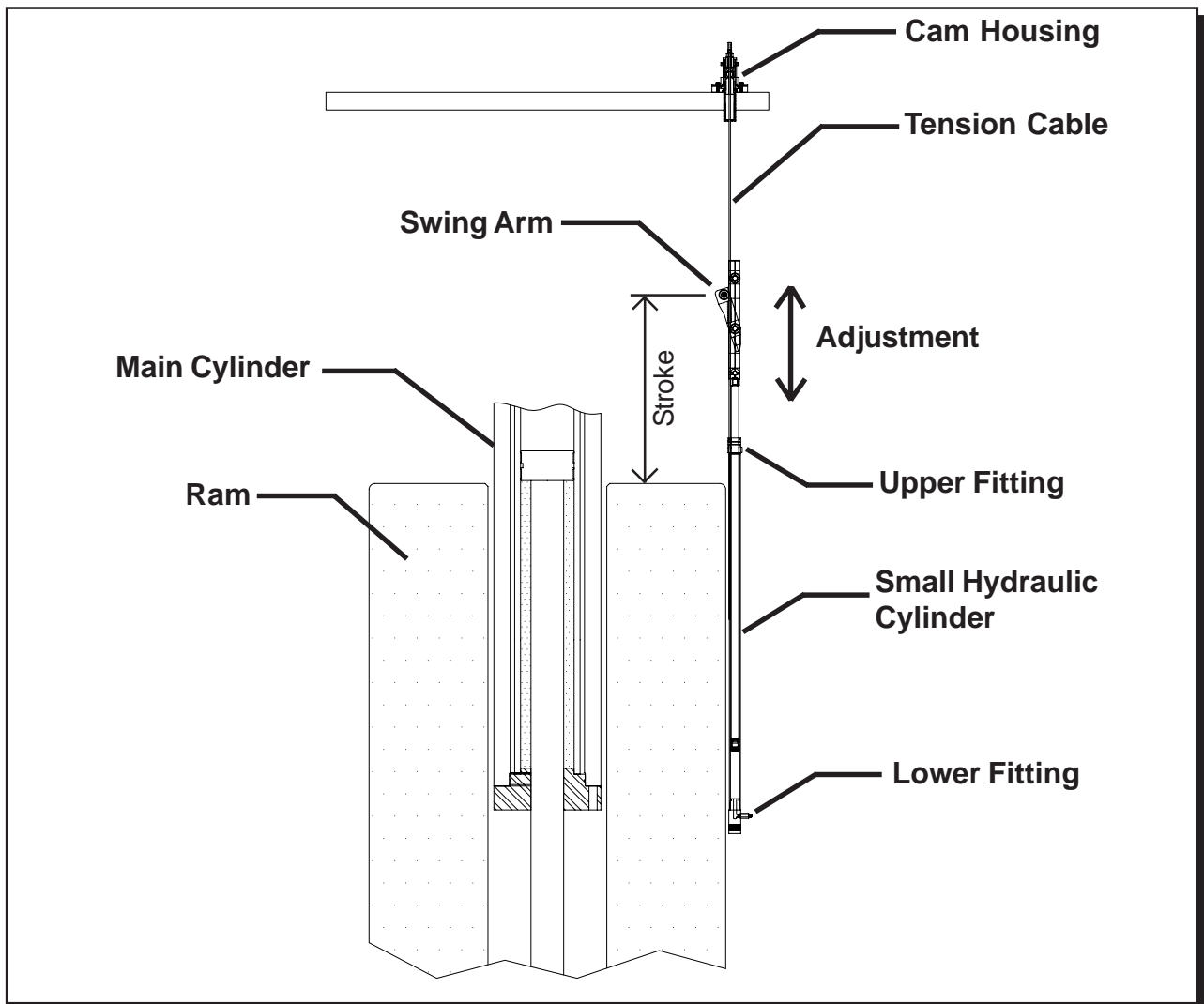

Figure 1-E. General Description of Stroke Control System



OPERATION / MAINTENANCE MANUAL

MODEL 750U HYDRAULIC IMPACT HAMMER

7032 SOUTH 196th - KENT, WA 98032 - (800) 248-8498 / FAX (253) 872-8710

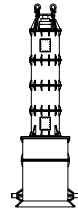

I. GENERAL INFORMATION (Continued...)

I-3D. Striker Plate / Bell Housing

The 750U is a direct drive hammer, which may be operated without a set of leads. The ram directly hits the striker plate, which in turn directly strikes the pile, or a cushion system if desired. The bell housing guides to the pile, and holds the hammer plumb. The bell housing is tapered to allow easy loading of the hammer onto the pile. The bell housing is adjustable, and will guide to a variety of pile sizes.

IMPORTANT: The actual diameter of the pile must be measured so that the guides in the bell housing can be adjusted or shimmed for a snug fit. The top of the pile must be checked for squareness and uniformity. Proper and safe driving will result only if there is continuous uniform contact between the top of the pile and the bottom of the striker plate.

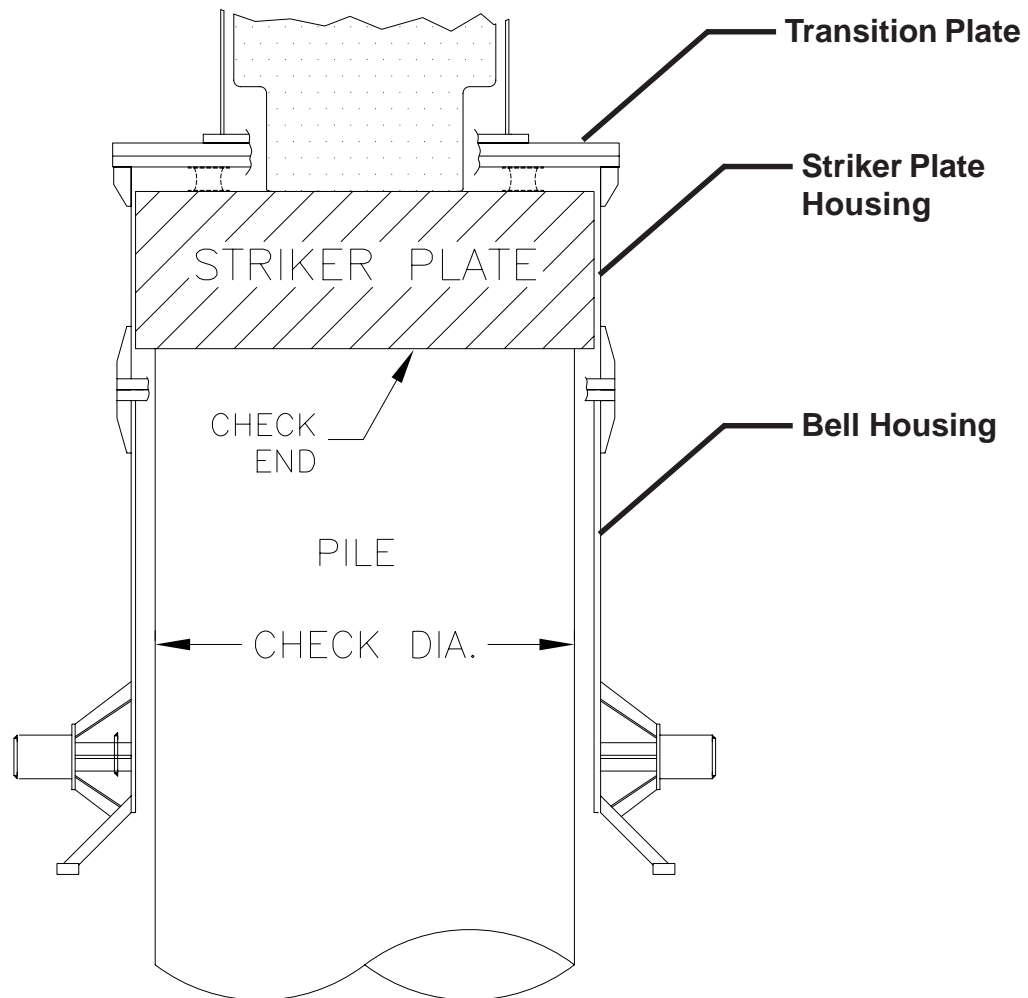
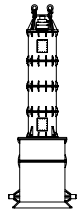

Figure 1-F. General Description of Striker Plate / Bell Housing



I. GENERAL INFORMATION (Continued...)

I-4. General Description of Model 1000 Power Unit

The 750U runs off the APE 1000 power unit. The APE 1000 has a CAT 1000 horsepower engine. The engine is mounted to a tubular frame that also serves as a diesel fuel tank. A sheet metal and tube frame covers the engine and is equipped with locking doors for protection from the environment. A control panel is located behind one of the doors and comes complete with a 50 foot (15m) control pendant. There are two hydraulic tanks on the power unit. One is the main tank and the other is a storage tank for extra oil in case the main tank becomes depleted.

The 750U is connected to the power unit via four hydraulic hoses.

HOSES - One 2" ID (38mm) hose is the pressure line and the other 2" ID (50mm) is the return line for the main hydraulic cylinder. The two 3/8" ID (9.5mm) hoses are for the stroke control system. The hoses are attached to the power unit by connecting the "quick disconnect fittings" on the end of the hoses leading from the vibrator. The fittings go on only one way so there is no chance of hooking up the hoses improperly.

WARNING: Before installing quick disconnects, clean with ether or a clean rag. Make sure you seat the quick disconnect fittings all the way tight. Failure to tighten the quick disconnects will stop the flow of oil and will prevent the vibro from operating. Failure to tighten the clamp fittings completely tight will cause the jaws to either not open or not close. If this happens you may have to crack the fitting and bleed off the pressure to release the quick disconnects.

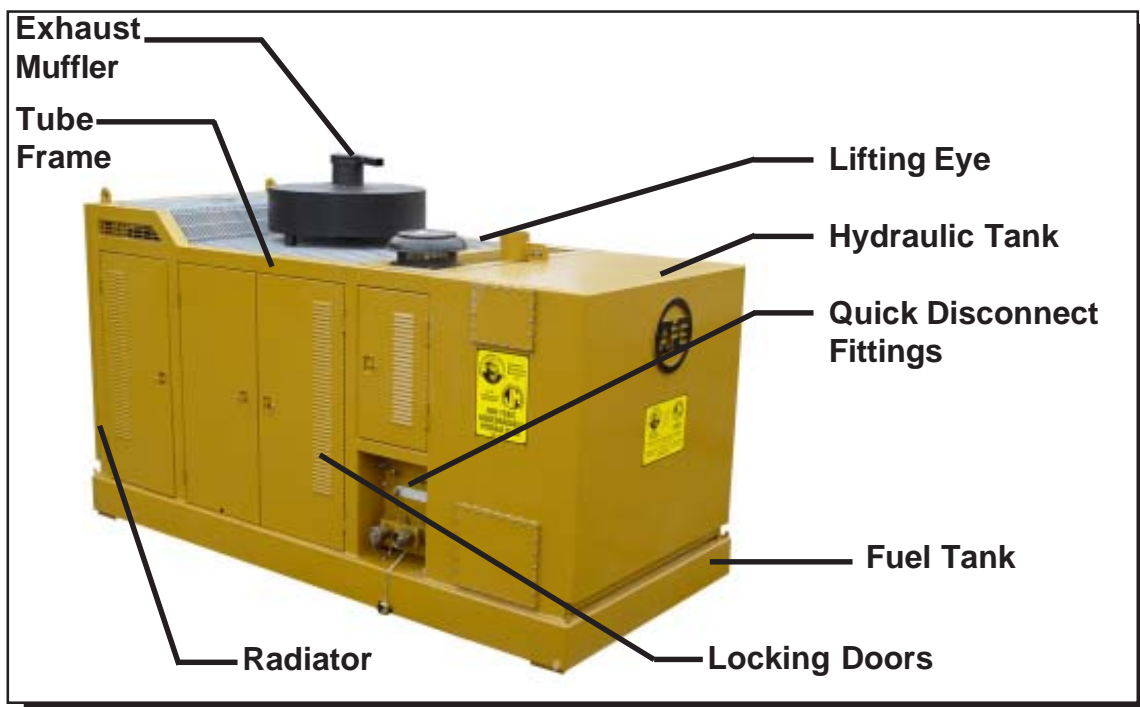

Figure 1-G. General Description of Model 1000 Power Unit



OPERATION / MAINTENANCE MANUAL

MODEL 750U HYDRAULIC IMPACT HAMMER

7032 SOUTH 196th - KENT, WA 98032 - (800) 248-8498 / FAX (253) 872-8710

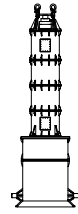

II. PREPARING THE 750U HAMMER

II-1. Assembling the 750U

The 750U will be shipped with the stroke control system intact, primary plumbing in place, and accumulators fully charged. Due to weight, large sub-assemblies are shipped separately. The ram will need to be installed, the steel cages will need to be bolted together, and the striker plate / bell housing will need to be bolted on. Hydraulics will need to be plumbed to the power unit and to the visual stroke indicator.

1. Un-bolt bottom steel cage section and place it vertically and securely onto concrete blocks, with the bottom center open and accessible.
2. Lift the ram vertically, and place it into the bottom cage section.
3. Inspect & adjust the stroke control system.
 - a. Make sure the cable is tight, the hydraulic stroke control cylinder is secure, and that there are no oil leaks.
 - b. Make sure that the sled is not bound, and will travel freely in the guide rails.
 - c. Make sure the pulleys are aligned and secure.
 - d. Push the swing arm fully; have an assistant inspect the cam and trip valve at the top of the hammer. The plunger of the trip valve should push in 0.25" to 0.44" from extended. **See figure 2-B.**
4. Lift the top section, (including 3 cage sections, top plate and main cylinder) onto the bottom cage section. The main cylinder and rod will need to go into and through the ram. Make sure that the plastic guard is placed on the cylinder rod to protect the threads. **See figure 2-A.**
5. Bolt steel cage sections together, using new 1-1/4" stover nuts.
6. Remove the plastic thread guard, and install the 1" thick nylatron lifting cushion onto cylinder rod.
7. Tighten down lifting nut and lock nut onto cylinder rod – torque down retainer bolts. **See figure 2-C.**
8. Place transition plate securely onto dunnage. Lift hammer onto transition plate and bolt together.
9. Place striker plate housing vertically and securely onto level surface.
10. Lift striker plate into striker plate housing.
11. Place bell housing vertically and securely onto level surface.
12. Lift striker plate with housing onto bell housing.
13. Bolt bell housing to striker plate housing.
14. Lift the hammer with transition plate onto the striker plate / bell assembly. Bolt together. Lift hammer and set into the cradle. **See figure 2-D.**
15. Connect the hoses per the diagrams. Make sure hoses are tight.
16. Inspect the hydraulic manifolds and control valve. Make sure all hoses are tight, and that there are no leaks.
17. Check the bolts on the top retainer plate (above the cylinder head) **See figure 2-E.** This ensures that the main cylinder will remain securely in place during driving.
18. Perform an overall visual inspection for loose parts, bolts, hoses & leaks.
19. Bleed the stroke control system per the instructions.
20. Bleed the main system only if necessary, with the hammer set vertically upon the pile.



OPERATION / MAINTENANCE MANUAL

MODEL 750U HYDRAULIC IMPACT HAMMER

7032 SOUTH 196th - KENT, WA 98032 - (800) 248-8498 / FAX (253) 872-8710

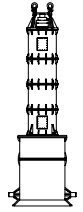

II. PREPARING THE 750U HAMMER (Continued...)



Figure 2-A. Lifting Main Cage & Cylinder onto Bottom Cage

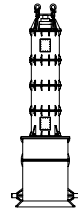

II. PREPARING THE 750U HAMMER (Continued...)

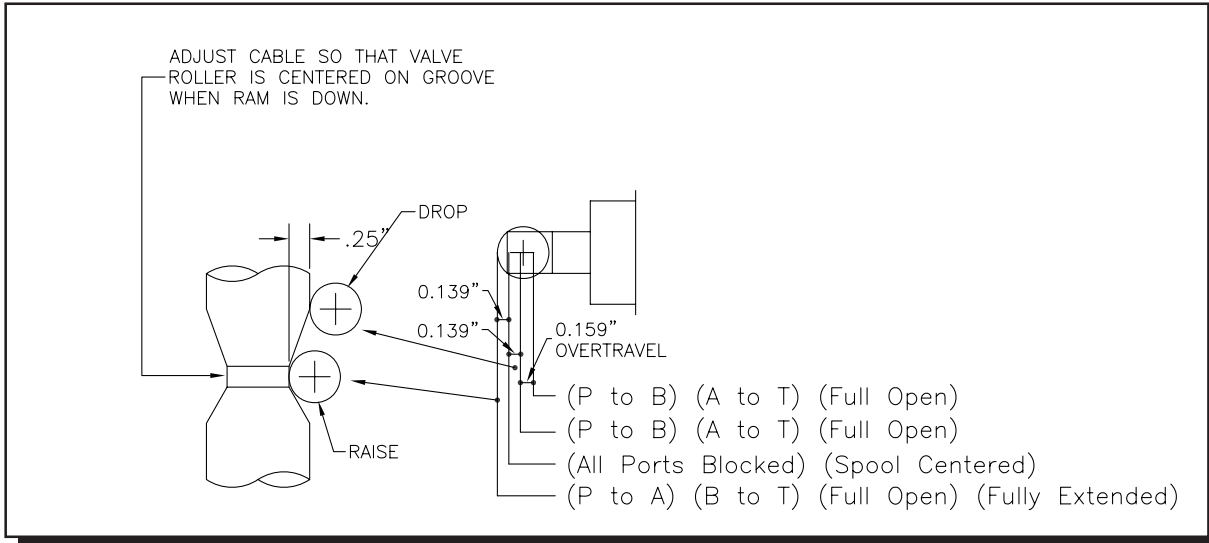

Figure 2-B. Adjusting the Stroke Control Cam / Valve

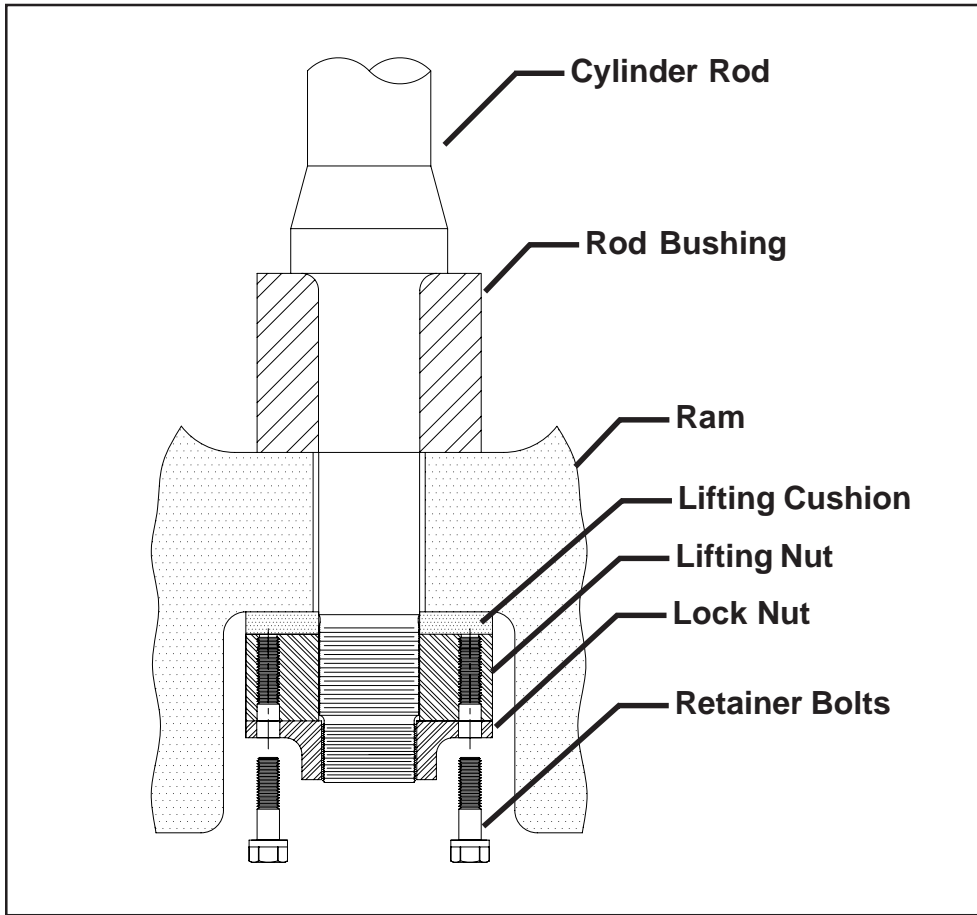
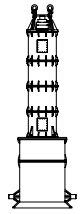

Figure 2-C. Installing Lifting Cushion, Nuts & Bolts



II. PREPARING THE 750U HAMMER (Continued...)

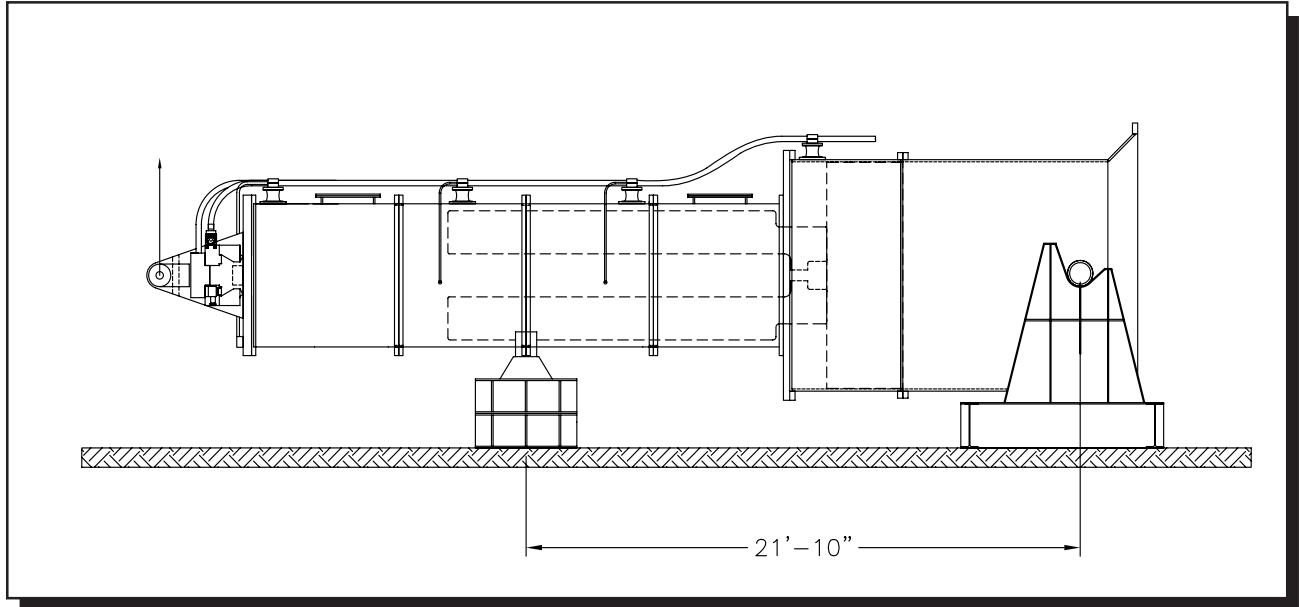

Figure 2-D. Placing the Hammer in the Cradle

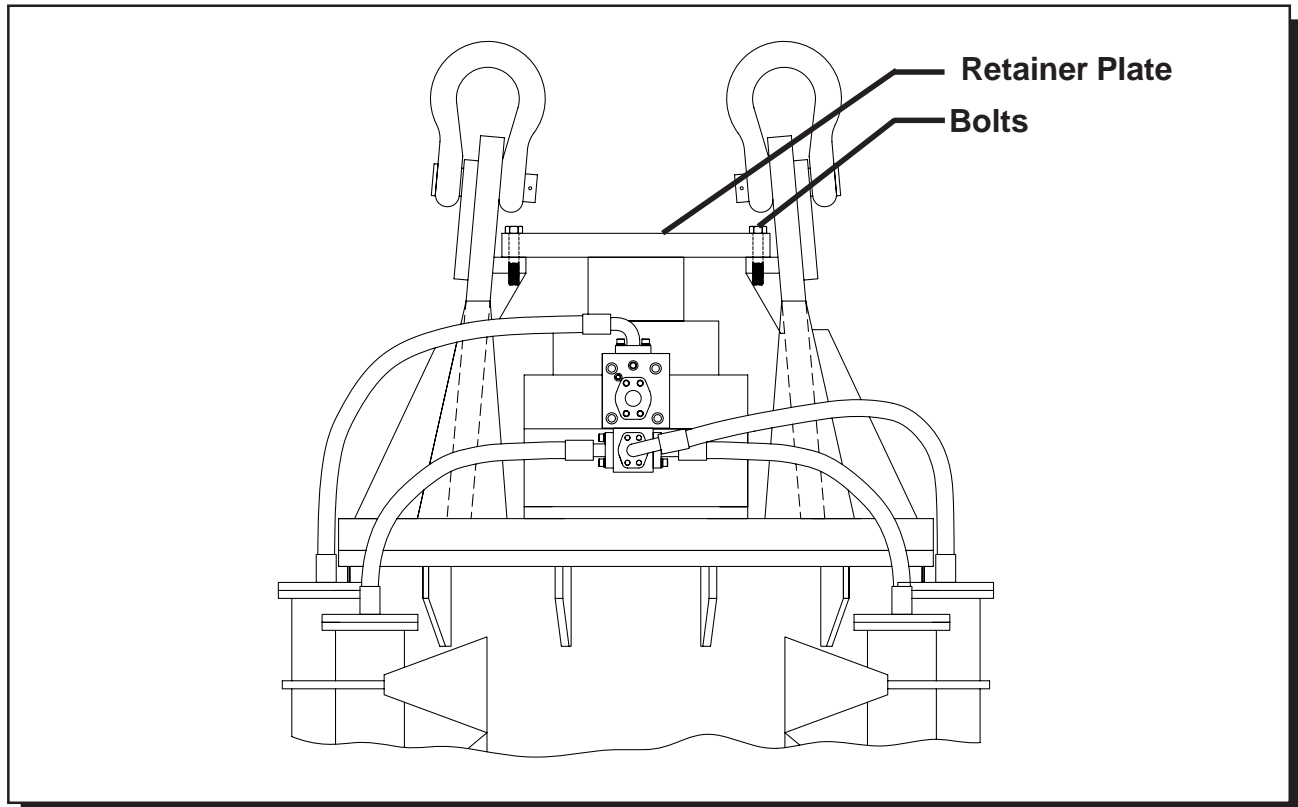

Figure 2-E. Checking the Top Retainer Plate



OPERATION / MAINTENANCE MANUAL

MODEL 750U HYDRAULIC IMPACT HAMMER

7032 SOUTH 196th - KENT, WA 98032 - (800) 248-8498 / FAX (253) 872-8710

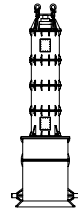

II. PREPARING THE HAMMER (Continued...)

II-2. Plumbing the Hoses to the Power Unit

There are four hoses leading from the vibro that must be connected to the power unit to begin operation. The hoses attach to the power unit by screwing the quick disconnect couplers onto the proper couplers of the power unit. The couplers on the power unit are mated with the couplers on the vibro so there is no chance of putting them on backwards. Please take the following steps when installing the couplers:

WARNING: TURN THE POWER UNIT OFF BEFORE INSTALLING COUPLERS

1. Turn the power unit OFF.
2. Clean all couplers with a can of ether if available. A clean dry cloth will also work but will require extreme care. Fittings must be spotless clean.
3. Install couplers by screwing them onto their respective counterparts. Try to avoid cross-threading and maintain a straight line. Jerk the hose back and forth while turning coupler to aid installation effort. **Push hard to get the big coupler threads started.**
4. Make sure fittings are tight. If they are properly cleaned they should run up tight with just a firm hand grip. However, they should be double checked with a chain wrench.
5. Avoid overtightening.
6. If near salt water, spray with a light oil to prevent oxidation.
7. Position the Power Unit so that vibrator has enough hose to reach the work. Avoid pulling too hard on hoses. Most hose failures are caused by pulling hoses off couplers.



Figure 2-F. Power Unit Coupler Layout



OPERATION / MAINTENANCE MANUAL

MODEL 750U HYDRAULIC IMPACT HAMMER

7032 SOUTH 196th - KENT, WA 98032 - (800) 248-8498 / FAX (253) 872-8710

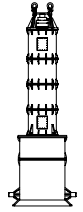

IV. PREPARING THE HAMMER (Continued...)

II-3. Filling the Pressure Hose

The 750U is shipped with the hoses filled with oil. However, if the unit has been sitting for a long period of time or if a damaged hose has been replaced with a new one, then the hoses must be filled. Hook up all the hoses to the power unit. Start the power unit and let it run for ten minutes before running the hammer.

WARNING: DO NOT BLEED SYSTEM AT FULL ENGINE THROTTLE BECAUSE TOO MUCH OIL WILL FLOW FROM THE HOSES AND COULD CAUSE INJURY.

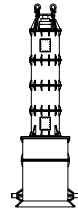

II. PREPARING THE 750U HAMMER (Continued...)

II-4. Setting up Stroke Control & Visual Indication System



Figure 2G. Visual Stroke Indicator Cylinder



Figure 2-H. Visual Stroke Indicator Cylinder - Rear

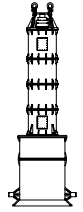

II. PREPARING THE 750U HAMMER (Continued...)

II-4. Setting up Stroke Control & Visual Indication System (Continued...)

1. Hook up hoses properly. **See figure 2-G, 2-H & 2-J.**
2. Turn both needle valves open, two turns from closed position.
3. Alternately cycle the system back and forth to fill the system.
4. Use Clamp-Close to retract the visual **Indicator Cylinder** & fully raise the stroke **Control Cylinder** (in hammer).
5. Close both needle valves.
6. Bleed the system.
 - a. Crack the “top” fitting at hammer, and cycle the cylinders back & forth a few inches. Tighten the fitting after all air is bled.
 - b. Use clamp-open to extend the visual **Indicator Cylinder** & fully lower the **Control cylinder**.
 - c. Crack the “bottom” fitting at hammer, and cycle the cylinders back & forth a few inches. Tighten the fitting after air is bled.
7. Cycle the cylinders to verify that each “gage foot” on the **Indicator Cylinder** corresponds to an actual foot on the **Control Cylinder**.
8. Perform a visual inspection to make sure that when the **Control Cylinder** in the hammer is fully down, the visual **Indicator Cylinder** reads 1.5 ft.
9. Also verify that when the **Control Cylinder** in the hammer is fully up, the visual **Indicator Cylinder** reads 6.0 ft.

Note: In order to verify that the system operates and indicates properly, measure the full stroke of the **Indicator Cylinder** with a tape measure. The full stroke of the **Indicator Cylinder** should be 14". The full stroke of the **Control Cylinder** should be 56".

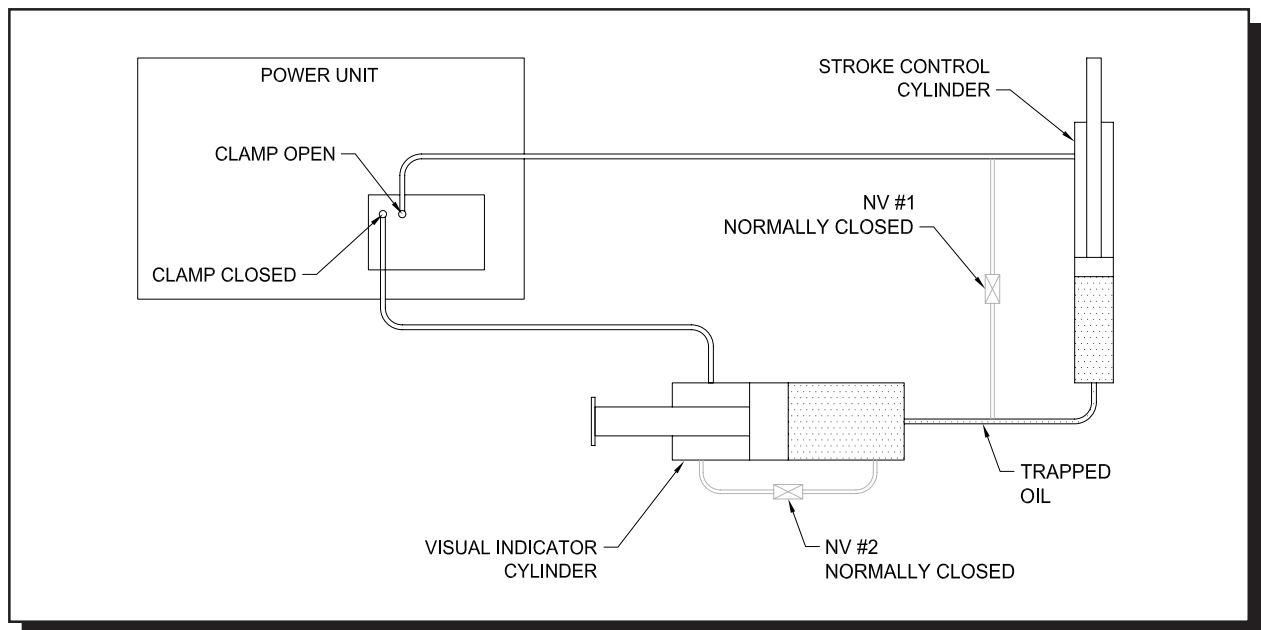

Figure 2-J. Stroke Indicator & Control System Schematic



OPERATION / MAINTENANCE MANUAL

MODEL 750U HYDRAULIC IMPACT HAMMER

7032 SOUTH 196th - KENT, WA 98032 - (800) 248-8498 / FAX (253) 872-8710

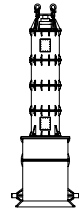

III. RUNNING THE 750U HAMMER

III-1. Selection of Control

The 750U may be operated either using the "**LOCAL**" control (the control panel on the power unit), or the "**PENDANT**" control (the handheld unit). The **PENDANT** control is normally the preferred method of operation, as it allows the operator the greatest mobility. Regardless, the operator should position himself with an unobstructed view of the stroke indicator, hammer, crane and signal man.

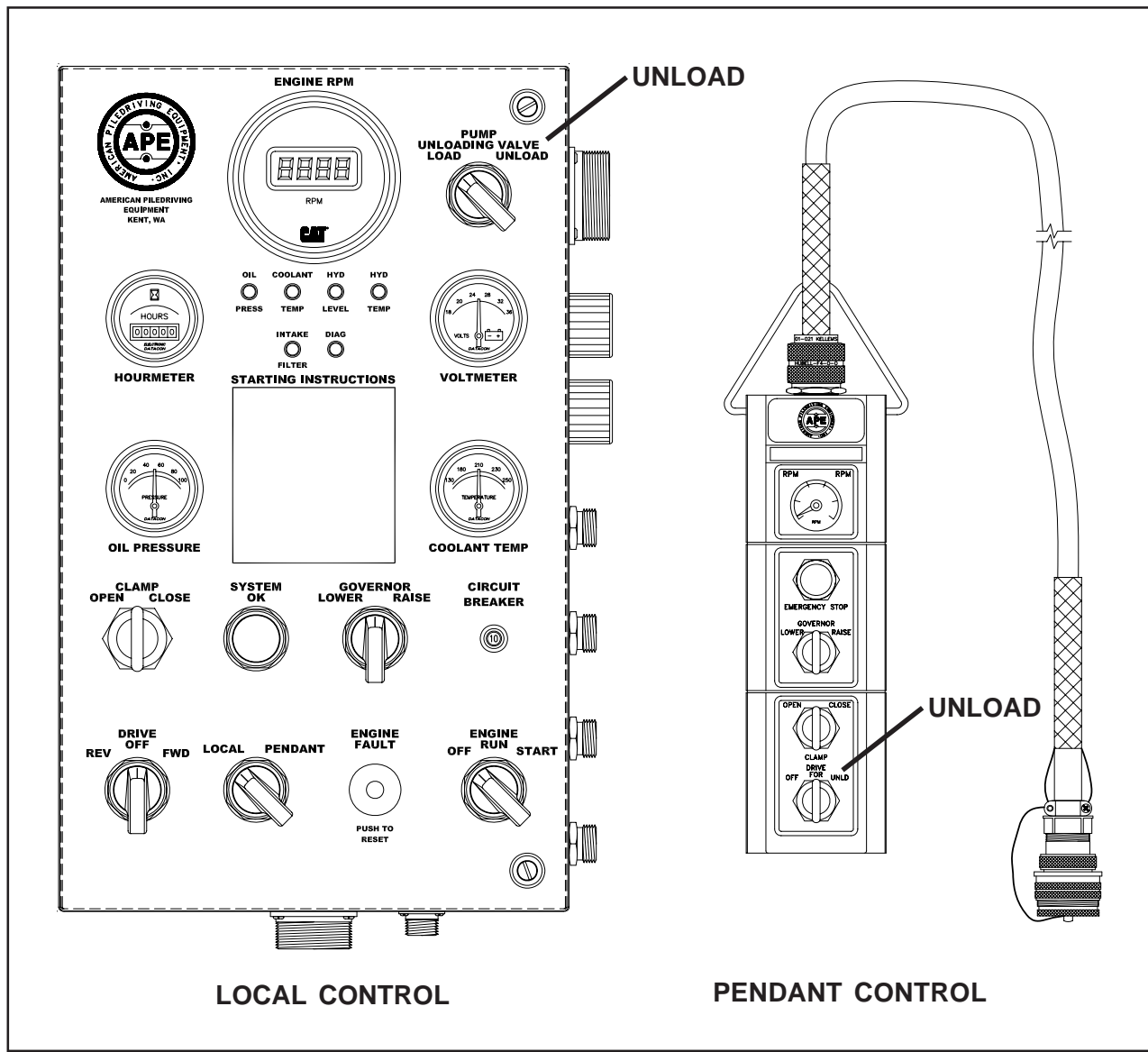

Figure 3-A. Selection of Control



OPERATION / MAINTENANCE MANUAL

MODEL 750U HYDRAULIC IMPACT HAMMER

7032 SOUTH 196th - KENT, WA 98032 - (800) 248-8498 / FAX (253) 872-8710

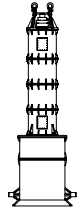

III. RUNNING THE 750U HAMMER (Continued...)

III-2. Procedure to Run Hammer - Stroke of 3 Feet or Less

1. Start and warm up power unit per procedure in power unit manual.
2. Decide whether to use **Local Panel** or **Pendant**.
3. If using **Local Panel**, make sure **Pump Unloading Valve** on panel is switched to “**UNLOAD**”.
4. Place hammer securely on pile. Striker plate should be loaded up against cushions. Lifting rigging should be slightly loose.
5. Set stroke to desired height using the **Clamp Open** or **Closed** switch. Use visual indicator to confirm stroke height.
6. Raise engine speed to 2000 RPM.
7. To operate hammer, turn **Drive Switch** to “**FWD**”. (If using **Pendant**, turn **Drive Switch** to “**UNLD**”.) Ram will raise and fall automatically. It will take a few cycles to achieve a consistent stroke, due to temperature effects of hydraulic oil.
8. **IMPORTANT** - Observe the pile. Crane operator must lower the hammer along with the pile, keeping the rigging slightly loose.
9. Increase or decrease the stroke as desired during driving, using the **Clamp Closed** or **Open** switch.
10. To stop hammer, turn **Drive Switch** to “**OFF**”.
11. Lower engine speed to idle.
12. **IMPORTANT** – Power unit can be shut down immediately by turning **Engine Run** switch to “**OFF**” at panel, or pushing the red **Emergency Stop** button on the pendant.

III-3. Procedure to Run Hammer - Stroke of More than 3 Feet (requires loading all pumps)

1. Make sure power unit has been warmed up.
2. Decide whether to use **Local Panel** or **Pendant**.
3. If using **Local Panel**, make sure **Pump Unloading Valve** on panel is switched to “**LOAD**”.
4. Make sure hammer is securely on pile, with striker plate loaded up against cushions. Lifting rigging should be slightly loose..
5. Set stroke to desired height using **Clamp Open** or **Closed** switch, and verify, using visual indicator.
6. Raise engine speed to 2100 RPM.
7. To start hammer, turn **Drive Switch** to “**FWD**”. (If using **Pendant**, turn **Drive Switch** to “**DRIVE FOR**”.) Ram will raise and fall automatically.
8. **IMPORTANT** - Observe the pile. Crane operator must lower the hammer along with the pile, keeping the rigging slightly loose.
9. Increase or decrease the stroke as desired during driving, using the **Clamp Closed** or **Open** switch.
10. To stop hammer, turn **Drive Switch** to “**OFF**”.
11. Lower engine speed to idle.
12. **IMPORTANT** – Power unit can be shut down immediately by turning **Engine Run** switch to “**OFF**” at panel, or pushing the red **Emergency Stop** button on the pendant.

Note: If operating below 3 ft stroke and increasing to greater than 3 ft stroke during operation of hammer, turn **Pump Unloading Valve** to “**LOAD**” (if using Panel) or turn **Drive Switch** to “**FOR**” (if using Pendant).



OPERATION / MAINTENANCE MANUAL

MODEL 750U HYDRAULIC IMPACT HAMMER

7032 SOUTH 196th - KENT, WA 98032 - (800) 248-8498 / FAX (253) 872-8710

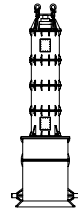

III. RUNNING THE 750U HAMMER (Continued...)

III-4. Shut-down Procedure

The following procedure explains how to correctly shut down the APE Model 750U Hammer and APE 1000 Power Unit.

1. Stop the hammer by turning "**DRIVE**" switch to **OFF**.
2. Allow the diesel engine to run for five minutes at 1000 engine rpm.
3. Reduce engine speed to low idle for about 60 seconds.
4. Shut engine off by turning off the main power switch.

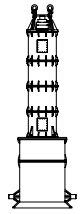

IV. HYDRAULIC CIRCUIT

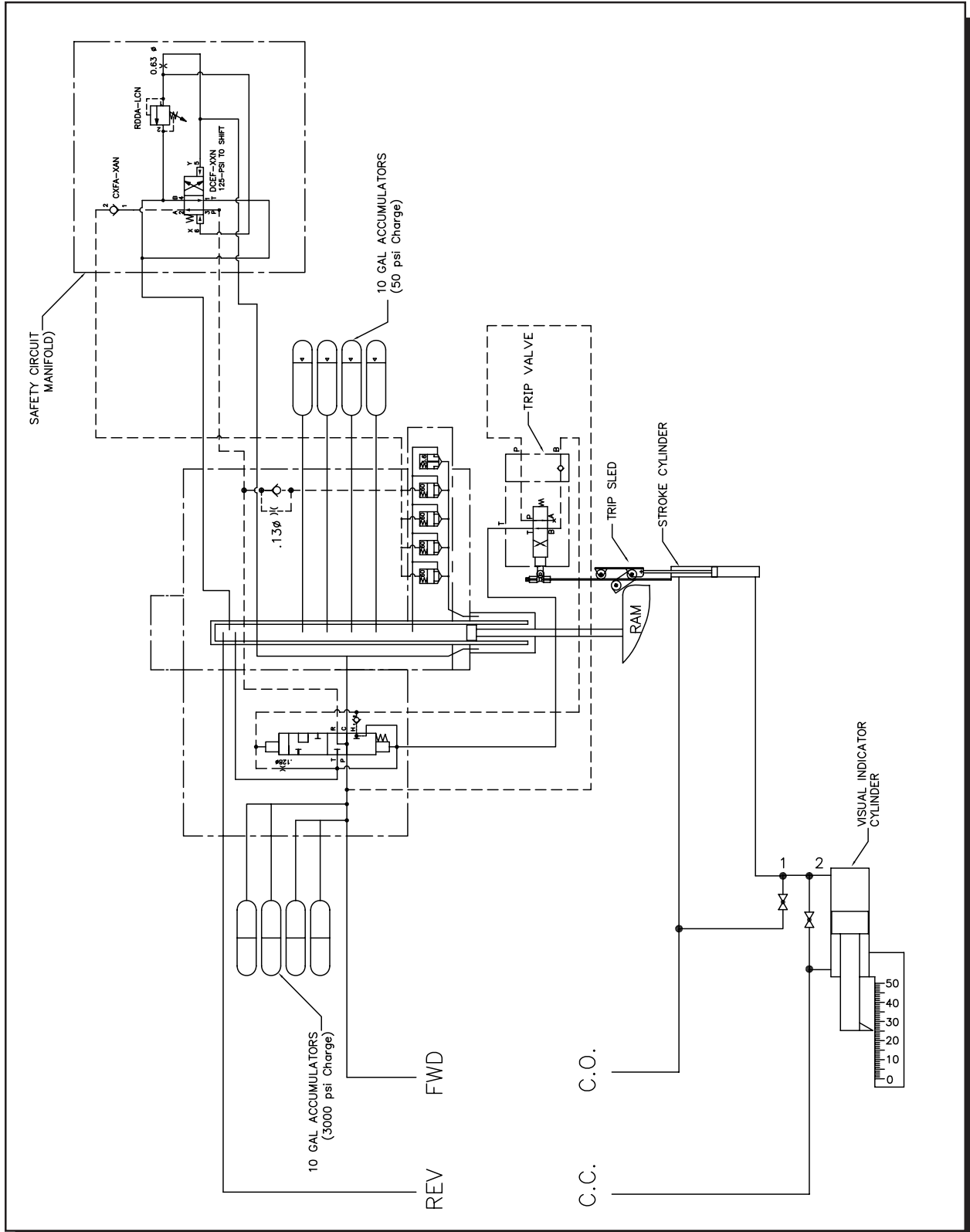

Figure 4-1. Hydraulic Circuit



OPERATION / MAINTENANCE MANUAL

MODEL 750U HYDRAULIC IMPACT HAMMER

7032 SOUTH 196th - KENT, WA 98032 - (800) 248-8498 / FAX (253) 872-8710

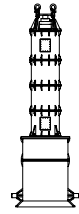

V. PARTS LISTS

V-1. Hammer Exterior

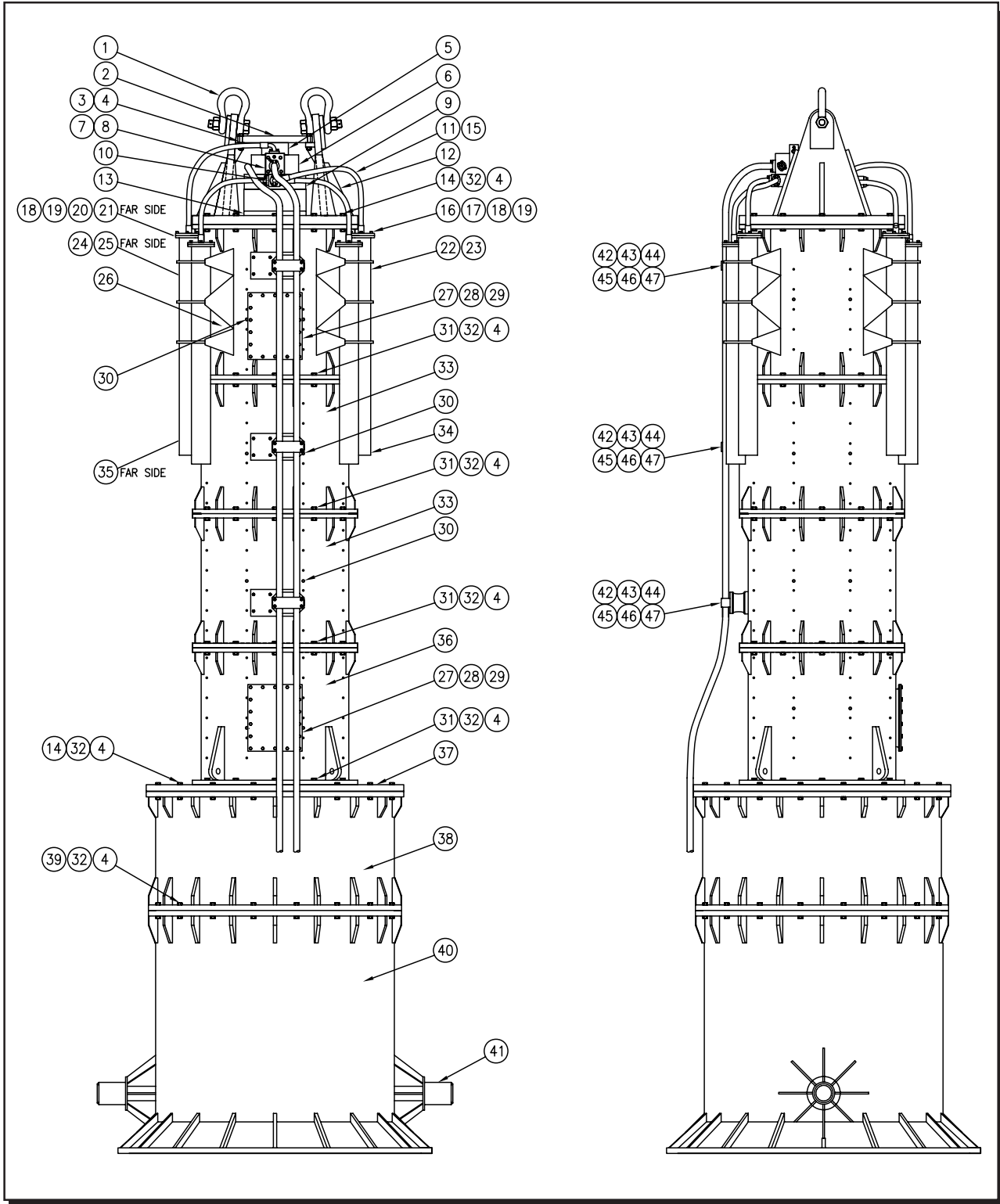



OPERATION / MAINTENANCE MANUAL

MODEL 750U HYDRAULIC IMPACT HAMMER

7032 SOUTH 196th - KENT, WA 98032 - (800) 248-8498 / FAX (253) 872-8710

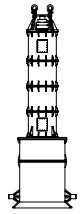

V. PARTS LISTS (Continued...)

Table 5-A Hammer Exterior

ITEM	P/N	QTY	DESCRIPTION	MFG./VENDOR	DWG
1	S-2140	2	120 TON SHACKLE	CROSBY	---
2	B-1196-1	1	COVER PLATE	APE	B-1196
3	B-1194-9	6	1-1/4"-7 X 6.50 GR 8 HEX BOLT	HI-STRENGTH	---
4	B-1194-9	168	1-1/4" STOVER NUT	HI-STRENGTH	---
5	B-1194-6	1	HEAD CUSHION	APE	---
6	A600-08	1	ACTUATOR CAP ASM	APE	A600-08
7	A600-09	1	CONTROL VALVE ASM	APE	A600-09
8	A600-12	1	SAFETY MANIFOLD ASM	APE	A600-12
9	A600-05	1	DIN CARTRIDGE BLOCK ASM	APE	A600-05
10	A-1750	1	HIGH PRESSURE FEED BLOCK	APE	A-1750
11	A600-33	1	750 HIH HOSE KIT	PACIFIC RUBBER	---
12	A-1194-1	1	TOP PLATE WELDMENT	APE	A-1194
13	A-1159	1	CYLINDER LIFTING CUSHION	URETHANE TECH	A-1159
14	A-1159-1	24	1-1/4" - 7 X 8.00 GR 8 HEX BOLT	HI-STRENGTH	---
15	A600-34	1	750 HIH HOSE FITTINGS KIT	PACIFIC RUBBER	---
16	B-1224-2	4	HI PRESSURE ACCUMULATOR TUBE LID	APE	B-1224
17	B-1224-3	4	HI PRESS ACCUMULATOR UPPER CUSHION	URETHANE TECH	B-1224
18	B-1224-4	48	3/4"-10 X 2.00 SHCS	HI-STRENGTH	---
19	B-1224-5	48	3/4" HI COLLAR LOCK WASHER	HI-STRENGTH	---
20	B-1225-2	4	LOW PRESSURE ACCUMULATOR TUBE LID	APE	B-1225
21	B-1225-3	4	LOW PRESS ACCUMULATOR UPPER CUSHION	URETHANE TECH	B-1225
22	B-1224-1	4	HI PRESSURE ACCUMULATOR TUBE	APE	B-1224
23	A6N2310C1K	4	HI PRESSURE ACCUMULATOR - 10 GALLON	PARKER	---
24	B-1225-1	4	LOW PRESSURE ACCUMULATOR TUBE	APE	B-1224
25	A6N2310D3KPL	4	LOW PRESSURE ACCUMULATOR - 10 GALLON	PARKER	---
26	B-1193	1	TOP CAGE	APE	B-1193
27	B-1235-1	2	ACCESS HATCH COVER	APE	B-1235
28	B-1193-1	24	3/4"-10 X 2.25 GR 8 HEX BOLT	HI-STRENGTH	---
29	B-1193-2	24	3/4"-10 STOVER NUT	HI-STRENGTH	---
30	B-1193-3	36	3/8 NPT BUTTON HEAD GREASE FITTING	ALEMITE	---
31	B-1193-4	72	1-1/4"-7 X 6.50 GR 8 HEX BOLT	HI-STRENGTH	---
32	B-1193-5	12	1.25 DIA X 3.00 HARDENED DOWEL PIN	APE	---
33	B-1236	2	MIDDLE CAGE SECTION	APE	B-1236
34	B-1224-6	4	HI PRESS ACCUMULATOR LOWER CUSHION	URETHANE TECH	B-1224
35	B-1225-6	4	LOW PRESS ACCUMULATOR LOWER CUSHION	URETHANE TECH	B-1225
36	B-1237	1	BOTTOM CAGE SECTION	APE	B-1237
37	B-1241	1	TRANSITION PLATE	APE	B-1241
38	B-1200	1	STRIKER PLATE HOUSING	APE	B-1200
39	B-1200-1	24	1-1/4" - 7 X 7.50 GR 8 HEX BOLT	HI-STRENGTH	---
40	B-1201	1	BELL HOUSING ASSEMBLY	APE	B-1201
41	B-1204	2	WELD-ON TRUNNIONS	APE	B-1204
42	A-1168	3	HOSE BLOCK SUPPORT PLATE	APE	A-1168
43	A-1167-1	3	ELASTOMER	APE	A-1168
44	B-1228	3	HOSE BRACKET MOUNTING PLATE	APE	B-1225
45	B-1227-1	3	HOSE BRACKET CLAMP PLATE	APE	B-1227
46	B-1227-2	6	3/4"-10 X 6.00 SQUARE HEAD BOLT	HI-STRENGTH	---
47	B-1227-3	6	3/4"-10 STOVER NUT	HI-STRENGTH	---



OPERATION / MAINTENANCE MANUAL

MODEL 750U HYDRAULIC IMPACT HAMMER

7032 SOUTH 196th - KENT, WA 98032 - (800) 248-8498 / FAX (253) 872-8710

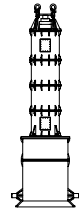

V. PARTS LISTS (Continued...)

V-1. Hammer Interior & Sub-Assemblies

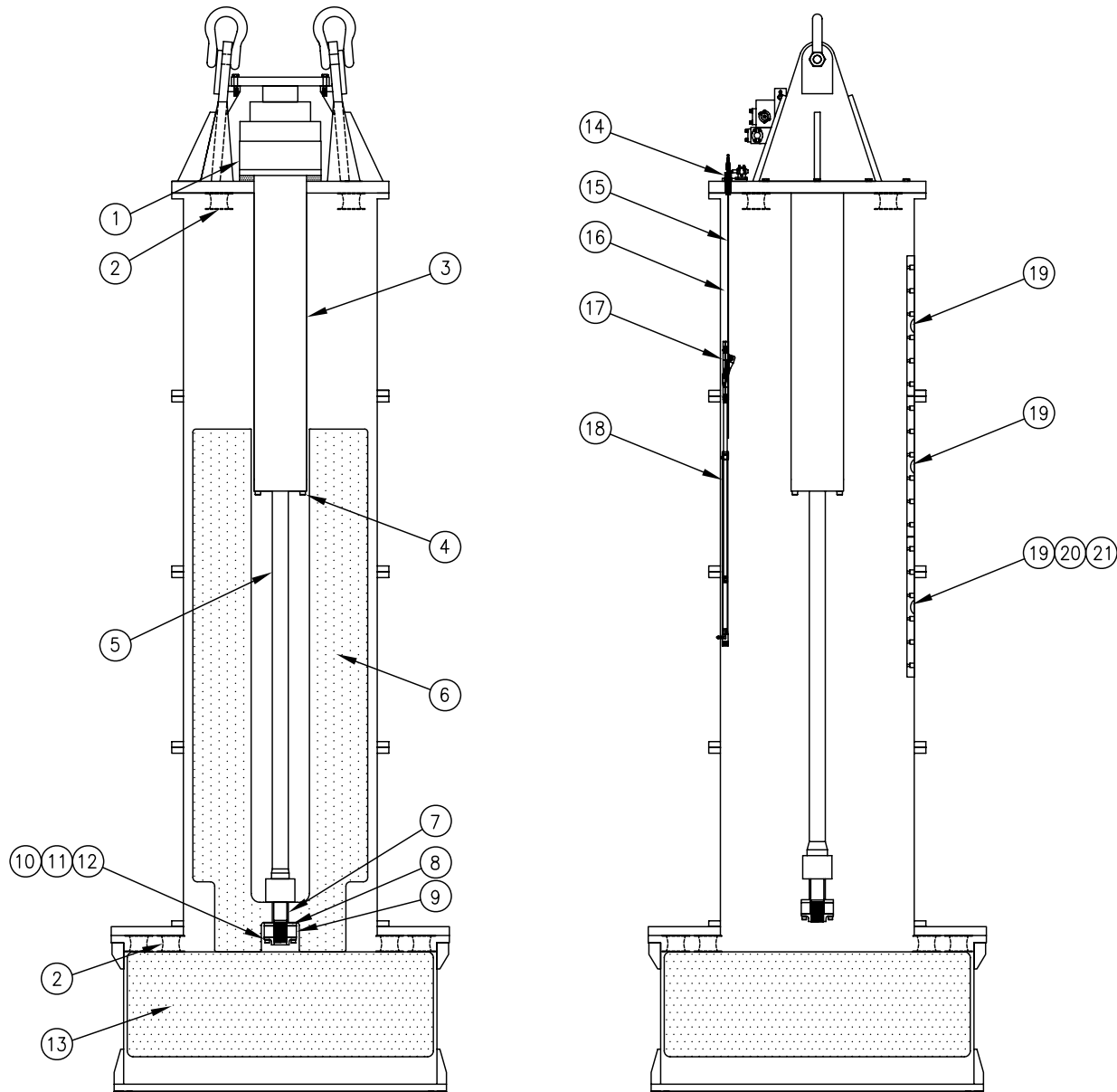

Figure 5-B. Hammer Interior & Sub-Assemblies



OPERATION / MAINTENANCE MANUAL

MODEL 750U HYDRAULIC IMPACT HAMMER

7032 SOUTH 196th - KENT, WA 98032 - (800) 248-8498 / FAX (253) 872-8710

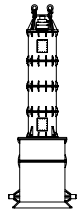

V. PARTS LISTS (Continued...)

Table 5-A Hammer Interior Parts & Sub-Assemblies

ITEM	P/N	QTY	DESCRIPTION	MFG./VENDOR	DWG
1	B-1181	1	CYLINDER VALVE BODY	APE	B-1181
2	B-1241-1	44	ELASTOMER	APE	---
3	B-1181-8	1	CYLINDER ASM	APE	B-1181
4	B-1181-12	24	1-1/4"-12 X 6.00 SHCS	HI-STRENGTH	---
5	B-1181-6	1	PISTON / ROD ASM	APE	B-1181
6	B-1191	1	60 TON RAM	APE	B-1181
7	B-1181-14	1	ROD BUSHING	APE	B-1181
8	B-1186-1	1	LIFTING CUSHION	APE	B-1186
9	B-1186-2	1	LIFTING NUT	APE	B-1186
10	B-1186-3	1	LOCK NUT	APE	B-1186
11	B-1186-4	12	1"-14 X 4.00 GR 8 HEX BOLT	HI-STRENGTH	B-1186
12	B-1186-5	12	1" HI-COLLAR LOCK WASHER	HI-STRENGTH	B-1186
13	A-1155	1	45 TON STRIKER PLATE	APE	A-1155
14	B-1243	1	STROKE CONTROL VALVE ASM	APE	B-1243
15	B-1243-5	1	ACTUATOR CABLE	APE	B-1243
16	A600-24	1	STROKE SLED GUIDE BEARING	APE	A600-24
17	A600-23	1	STROKE CONTROL SLED ASM	APE	A600-23
18	A600-25	1	STROKE CYLINDER ASM	APE	A600-25
19	B-1239-2	1	RAM BEARING	APE	B-1239
20	B-1239-3	152	5/8"-11 X 2.75 SHCS	HI-STRENGTH	B-1239
21	B-1239-4	152	5/8" NYLOCK NUT	HI-STRENGTH	B-1239

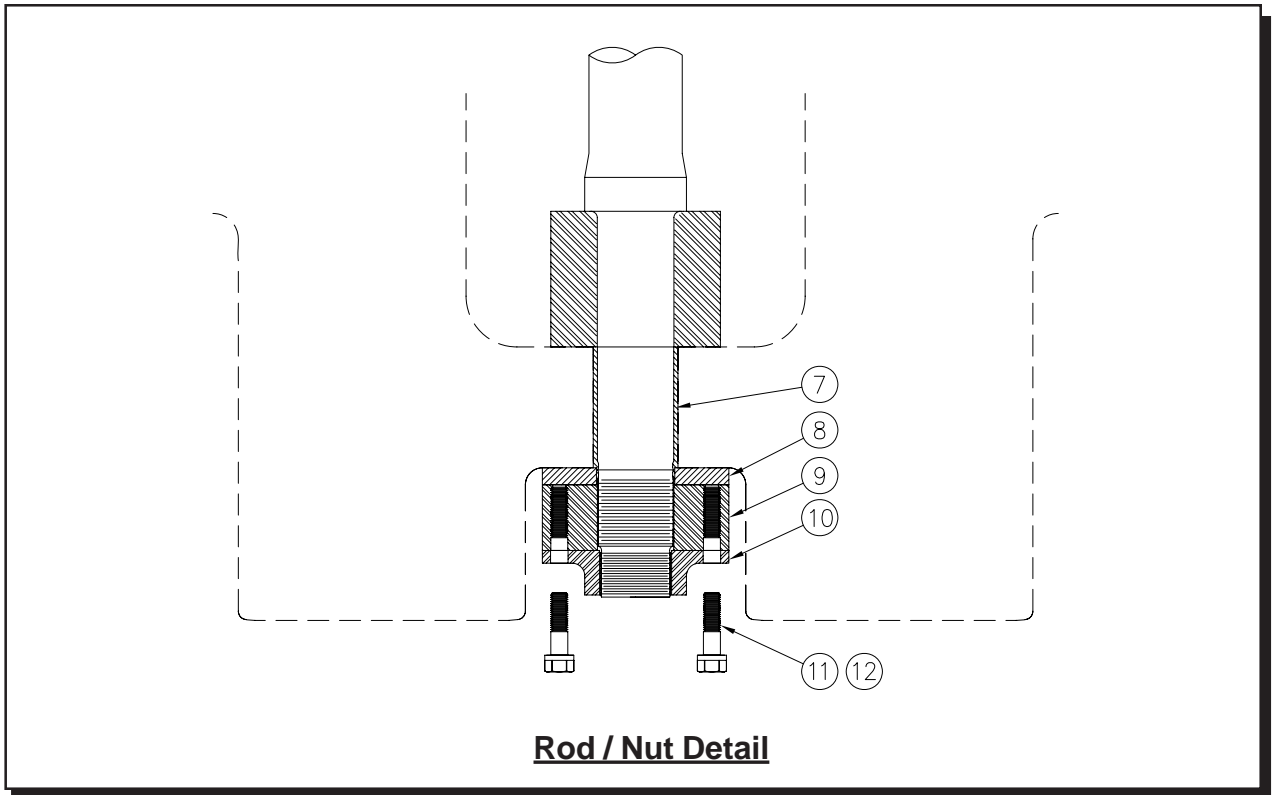

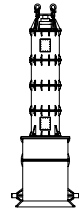

V. PARTS LISTS (Continued...)

V-3. Spool Valve Assembly

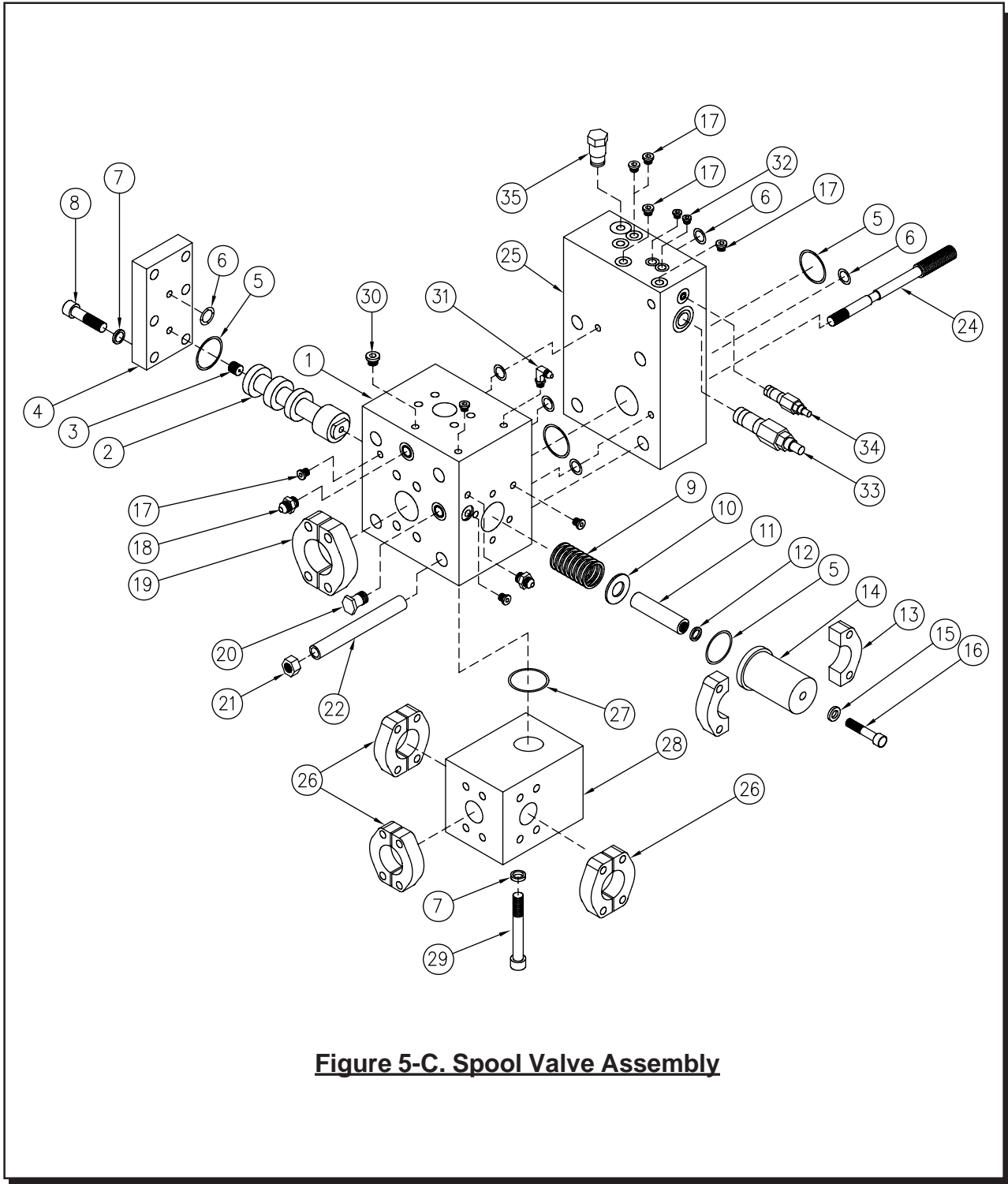

Figure 5-C. Spool Valve Assembly



OPERATION / MAINTENANCE MANUAL

MODEL 750U HYDRAULIC IMPACT HAMMER

7032 SOUTH 196th - KENT, WA 98032 - (800) 248-8498 / FAX (253) 872-8710

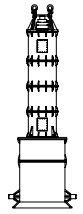

V. PARTS LISTS (Continued...)

V-3. Spool Valve Assembly (Continued...)

Table 5-C. Spool Valve Assembly

ITEM	P/N	QTY	DESCRIPTION	MFG./VENDOR	DWG
1	A600-09	1	SPOOL VALVE BODY	APE	A600-09
2	160603	1	SPOOL	J&M	160603
3	160604	1	SAE #6 PLUG w/ 0.128" ORIFICE DRILL	J&M	---
4	A-1626	1	SPOOL VALVE CAP	APE	A-1626
5	BIN STOCK	1	O-RING 2-228	PARKER	---
6	BIN STOCK	6	O-RING 2-210	PARKER	---
7	BIN STOCK	10	5/8" HI-COLLAR LOCK WASHER	HI-STRENGTH	---
8	BIN STOCK	6	5/8"-11 X 2.50 SHCS	J&M	---
9	160809	1	SPRING	HI-STRENGTH	---
10	BIN STOCK	2	1" WASHER	HI-STRENGTH	---
11	160599	1	SPOOL STOP	J&M	160599
12	BIN STOCK	1	O-RING 2-208	PARKER	---
13	1901-32	1	2" CODE 61 SPLIT FLANGE KIT	BRENNAN	---
14	160597	1	SPRING CAP	J&M	160597
15	BIN STOCK	1	1/2" STD. WASHER	HI-STRENGTH	---
16	BIN STOCK	1	1/2"-13 X 1.50 SHCS	HI-STRENGTH	---
17	BIN STOCK	8	#6 SAE FLUSH PLUG	PAC. RUBBER	---
18	BIN STOCK	2	#6 SAE X #6 JIC	PAC. RUBBER	---
19	1902-32	1	2" CODE 62 SPLIT FLANGE KIT	BRENNAN	---
20	160323	1	CHECK VALVE	J&M	---
21	BIN STOCK	4	5/8"-18 STOVER NUT	HI-STRENGTH	---
22	A600-10	4	SPACER SLEEVE	APE	A600-10
24	A600-11	4	STEP STUD	APE	A600-11
25	A600-12	1	SAFETY MANIFOLD	APE	A600-12
26	1902-24	5	1.5" CODE 62 SPLIT FLANGE KIT	BRENNAN	---
27	BIN STOCK	1	O-RING 2-225	---	---
28	A-1750	1	FEED BLOCK	APE	A-1750
29	BIN STOCK	4	5/8"-11 X 6.50 SHCS	HI-STRENGTH	---
30	BIN STOCK	1	#8 SAE FLUSH PLUG	PAC. RUBBER	---
31	BIN STOCK	1	#6 SAE X #6 JIC - 90 DEG.	PAC. RUBBER	---
32	BIN STOCK	2	#4 SAE FLUSH PLUG	PAC. RUBBER	---
33	DCEF-XXN	1	SEQUENCE VALVE DCEF-XXN (125 PSI SHIFT)	SUN HYDRAULICS	---
34	RDDA-LCN	1	RELIEF VALVE RDDA-LCN	SUN HYDRAULICS	---
35	CXFA-XAN	1	CHECK VALVE CXFA-XAN	SUN HYDRAULICS	---



OPERATION / MAINTENANCE MANUAL

MODEL 750U HYDRAULIC IMPACT HAMMER

7032 SOUTH 196th - KENT, WA 98032 - (800) 248-8498 / FAX (253) 872-8710

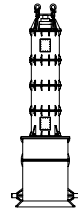

V. PARTS LISTS (Continued...)

V-4. Primary Manifold Assembly

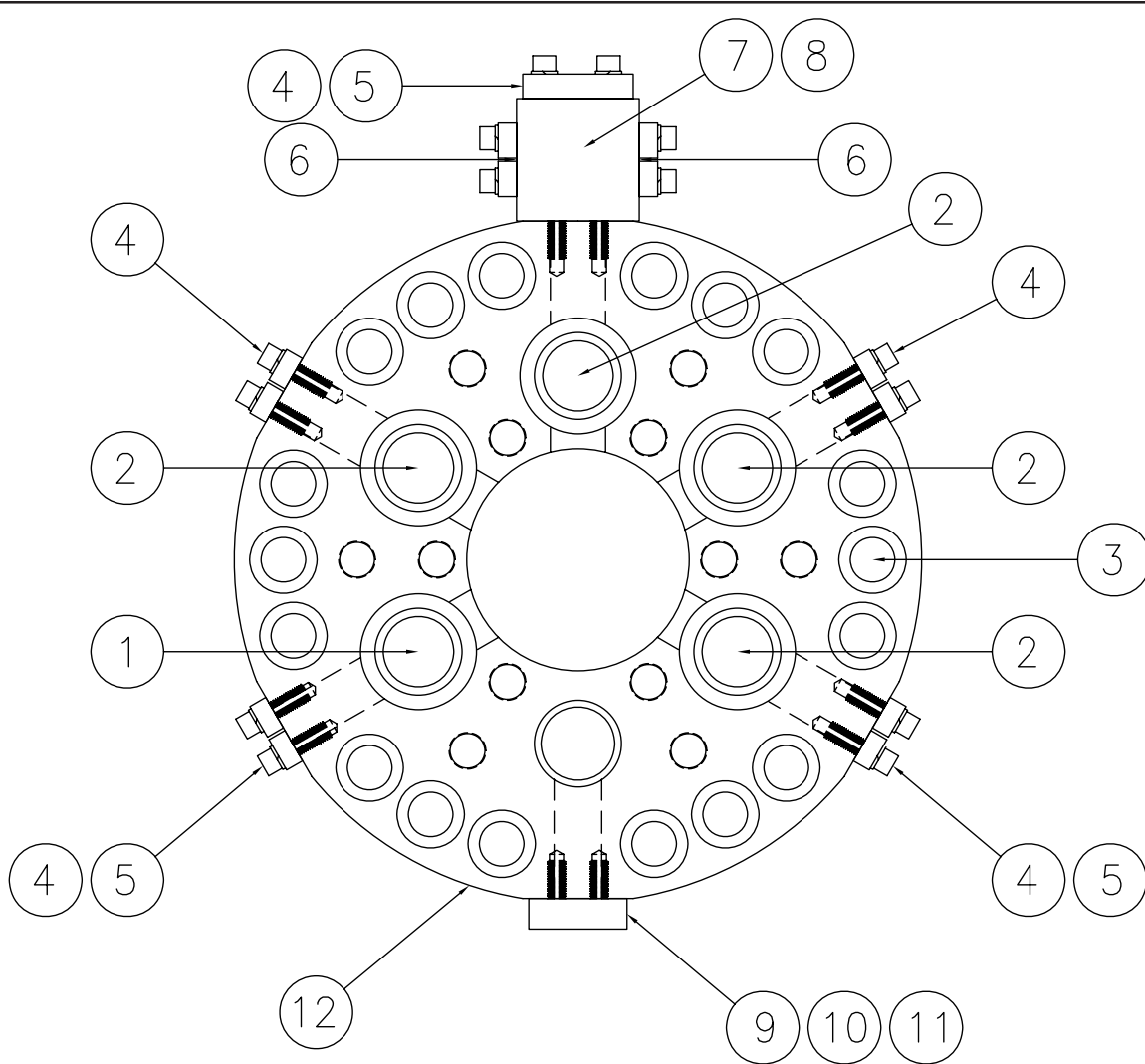
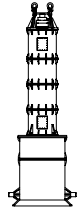

Figure 5-D. Primary Valve Assembly

ITEM	P/N	QTY	DESCRIPTION	MFG./VENDOR	DWG
1	CEE63B6BO/K99	1	DIN 63 CHECK VALVE CARTRIDGE	OILGEAR	---
2	CEE63B6BU/K0B	4	DIN 63 CONTROL VALVE CARTRIDGE	OILGEAR	---
3	VENDOR STOCK	18	1-1/8"-12 X 9.00 SHCS	APE	---
4	1902-32	5	2" CODE 62 SPLIT FLANGE KIT	BRENNAN	---
5	VENDOR STOCK	3	2" PLUG	BRENNAN	---
6	1902-24	2	1.5" CODE 62 SPLIT FLANGE KIT	BRENNAN	---
7	B-1229	1	FLANGE T-BLOCK (LOW-PRESSURE SIDE)	APE	B-1229
8	BIN STOCK	4	3/4"-10 X 6.00 SHCS	HI-STRENGTH	---
9	A-1753	1	BLOCKING PLATE	APE	A-1753
10	BIN STOCK	1	O-RING 2-228	PARKER	---
11	BIN STOCK	4	3/4"-10 X 1.50 SHCS	HI-STRENGTH	---
12	A600-05	1	DIN CARTRIDGE BLOCK	HI-STRENGTH	A600-05



V. PARTS LISTS (Continued...)

V-5. Secondary Manifold Assembly

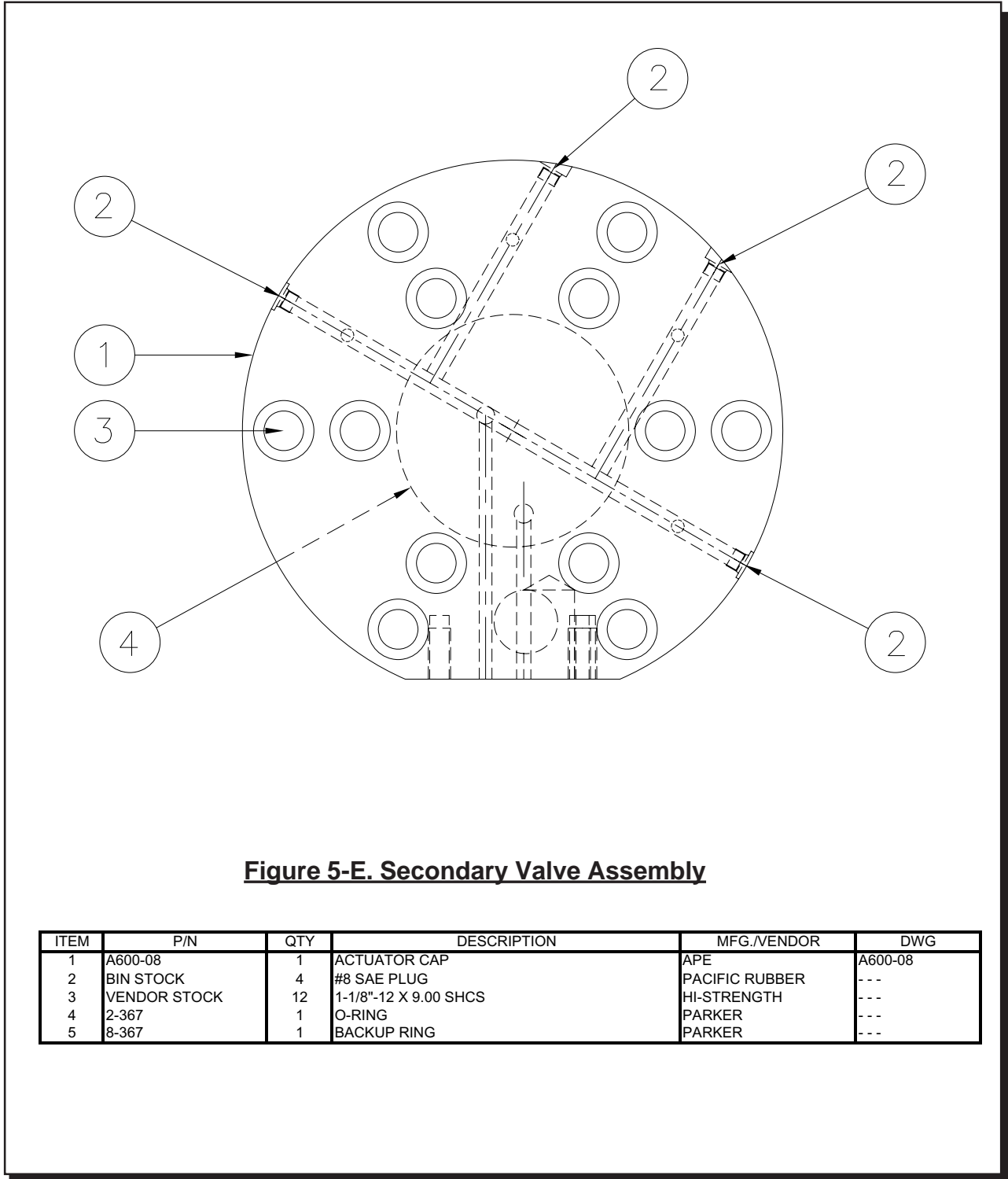

Figure 5-E. Secondary Valve Assembly

ITEM	P/N	QTY	DESCRIPTION	MFG./VENDOR	DWG
1	A600-08	1	ACTUATOR CAP	APE	A600-08
2	BIN STOCK	4	#8 SAE PLUG	PACIFIC RUBBER	---
3	VENDOR STOCK	12	1-1/8"-12 X 9.00 SHCS	HI-STRENGTH	---
4	2-367	1	O-RING	PARKER	---
5	8-367	1	BACKUP RING	PARKER	---



OPERATION / MAINTENANCE MANUAL

MODEL 750U HYDRAULIC IMPACT HAMMER

7032 SOUTH 196th - KENT, WA 98032 - (800) 248-8498 / FAX (253) 872-8710

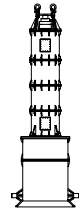

V. PARTS LISTS (Continued...)

V-6. Hydraulic Cylinder (Main)

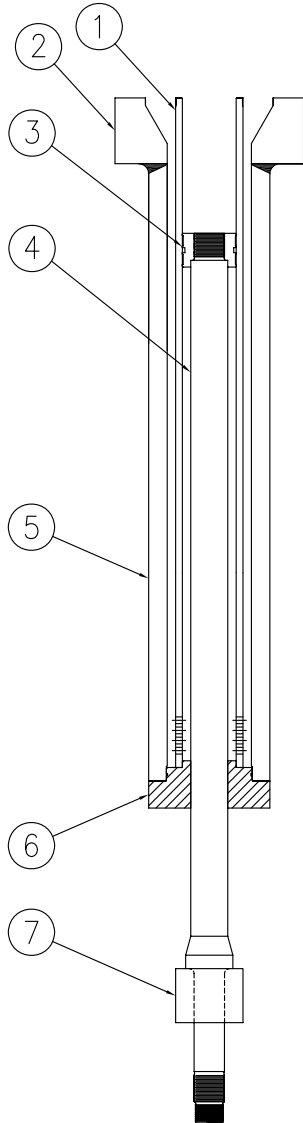
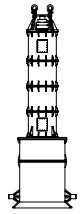

Figure 5-F. Hydraulic Cylinder (Main)

ITEM	P/N	QTY	DESCRIPTION	MFG./VENDOR	DWG
1	B-1181-09	1	CYLINDER INNER BARREL	APE	B-1181
2	B-1181-14	1	CYLINDER HEAD	APE	B-1181
3	B-1181-06	1	PISTON	APE	B-1181
4	B-1181-06	1	ROD	APE	B-1181
5	B-1181-08	1	CYLINDER OUTER BARREL	APE	B-1181
6	B-1181-7	1	CYLINDER GLAND	APE	B-1181
7	B-1181-12	24	1-1/4"-12 X 6.50 SHCS	HI-STRENGTH	- - -



V. PARTS LISTS (Continued...)

V-7. Trip Valve Assembly

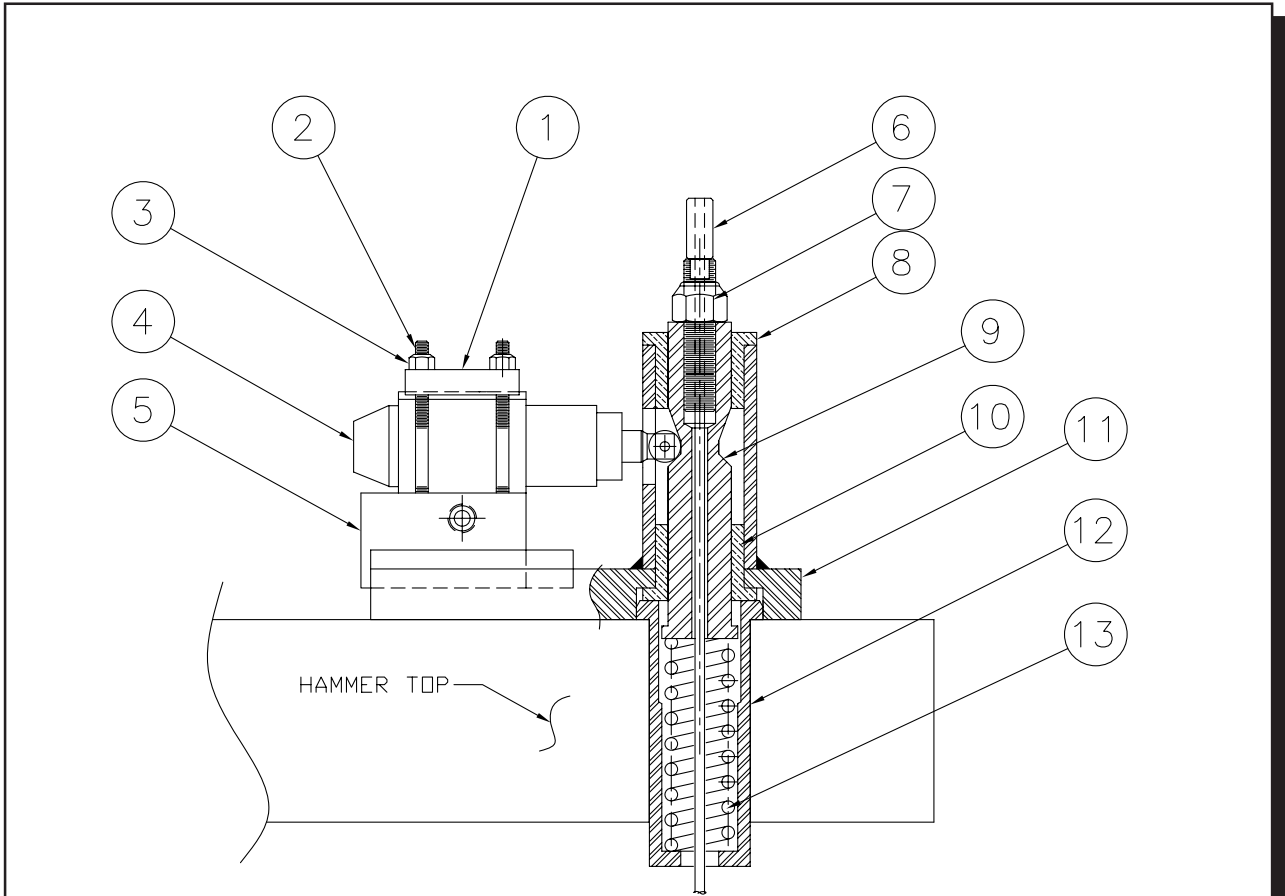
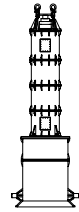

Figure 5-G. Trip Valve Assembly

ITEM	P/N	QTY	DESCRIPTION	MFG./VENDOR	DWG
1	A600-18	1	VALVE RETAINER	APE	A600-18
2	BIN STOCK	4	1/4"-20 X 3.50 B7 STUD	HI-STRENGTH	---
3	BIN STOCK	4	1/4"-20 NYLOCK NUT	HI-STRENGTH	---
4	D1VC1BNP05	1	DIRECTIONAL CONTROL VALVE	PARKER	---
5	A600-13	1	HYDRAULIC SUB PLATE	APE	A600-13
6	A-1751	1	1/4" CONTROL CABLE	WCWR	A-1751
7	A600-27	1	ADJUSTING SLEEVE	APE	A600-27
8	A600-16	1	BUSHING - UPPER	APE	A600-16
9	A600-25	1	PLUNGER (CAM)	APE	A600-25
10	A600-16	1	BUSHING - LOWER	APE	A600-16
11	A600-14	1	TRIP VALVE BASE	APE	A600-14
12	A600-17	1	SPRING CAGE	APE	A600-17
13	9-2420-1	1	COMPRESSION SPRING	LEMPCO	---
14	A600-15	1	CLAMP PLATE	APE	A600-15



V. PARTS LISTS (Continued...)

V-8 . Stroke Control Assembly

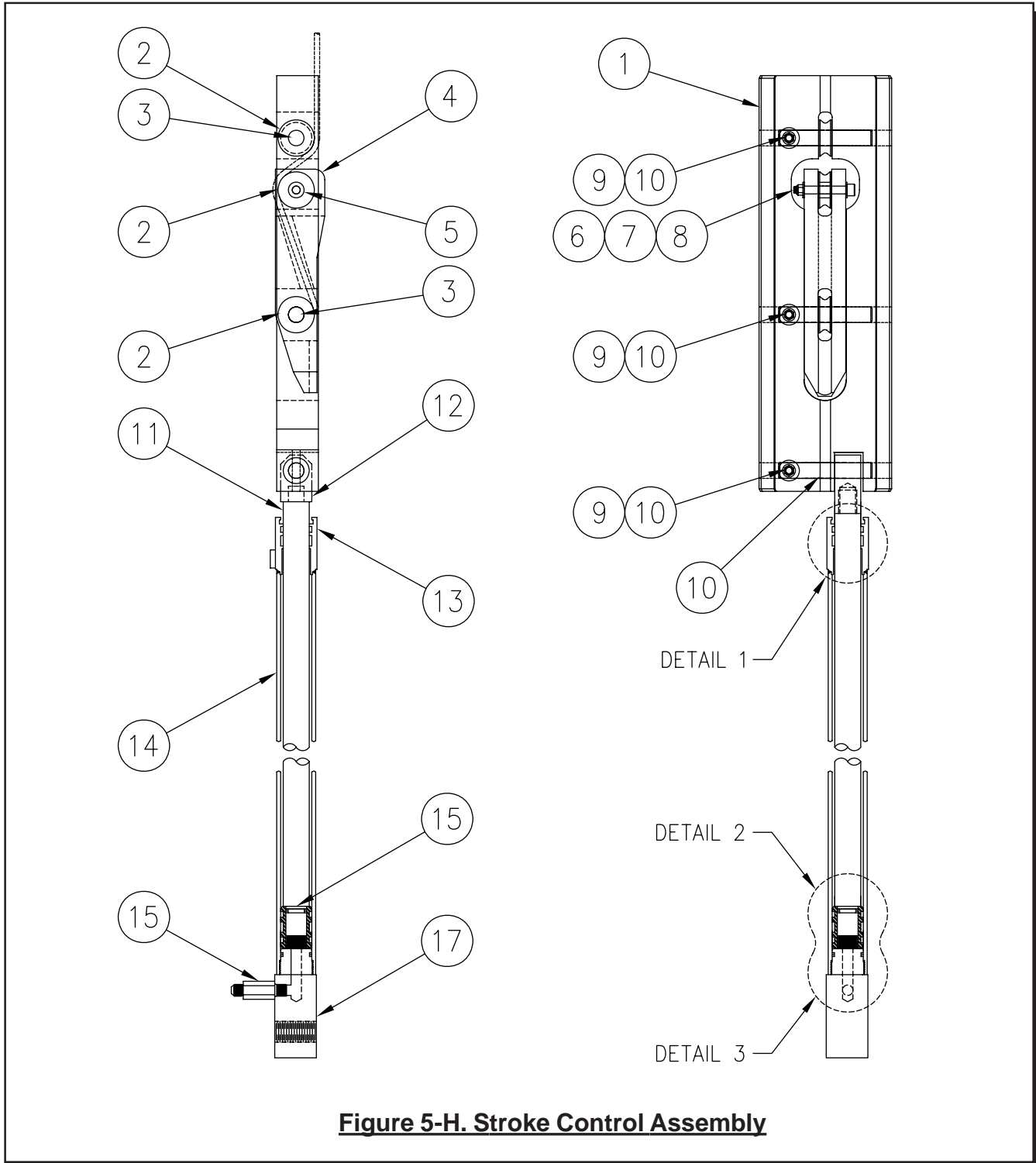
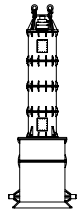

Figure 5-H. Stroke Control Assembly



V. PARTS LISTS (Continued...)

V-8 . Stroke Control Assembly (Continued...)

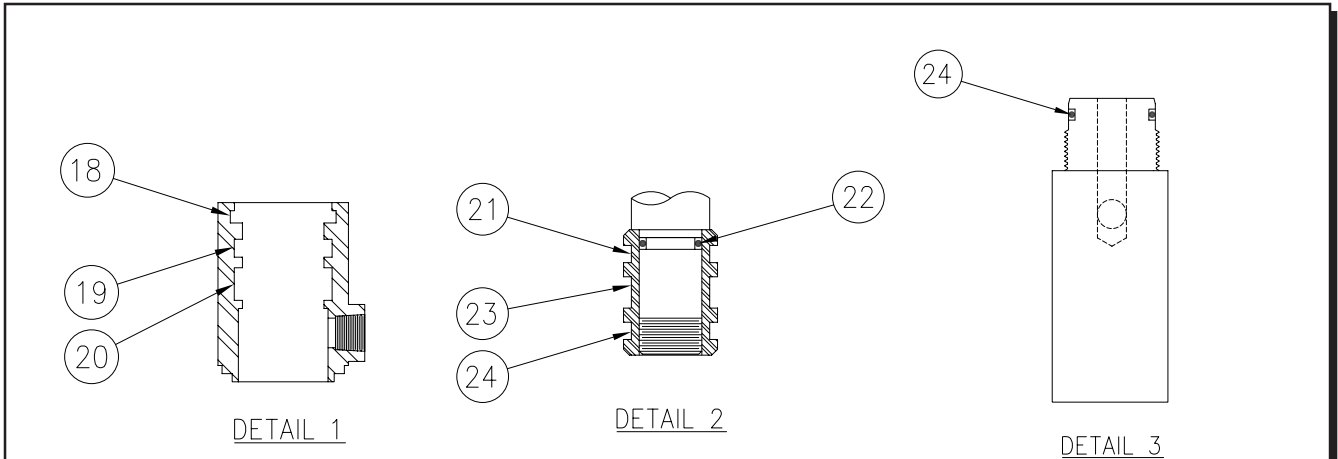
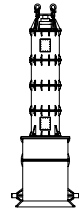

Figure 5-J. Stroke Control Assembly Details

Table 5-H. Stroke Control Assembly

ITEM	P/N	QTY	DESCRIPTION	MFG./VENDOR	DWG
1	A600-23	1	TRIP SLED	APE	A600-23
2	A600-19	3	SHEAVE	APE	A600-19
3	A600-20	3	TRIP SHAFT	APE	A600-20
4	A600-22	1	TRIP LEVER	APE	A600-22
5	A600-21	1	TRIP SHEAVE BUSHING	APE	A600-21
6	BIN STOCK	1	3/8"-16 X 2.50 SHCS	HI-STRENGTH	---
7	BIN STOCK	2	3/8" FLAT WASHER	HI-STRENGTH	---
8	BIN STOCK	1	3/8"-16 NYLOCK NUT	HI-STRENGTH	---
9	BIN STOCK	3	3/8"-16 X 1.50 SHCS	HI-STRENGTH	---
10	BIN STOCK	3	3/8"-16 HI-COLLAR LOCK WASHER	HI-STRENGTH	---
11	A600-30	1	CYLINDER ROD	APE	A600-30
12	A600-29	2	CYLINDER ROD LUG	APE	A600-29
13	A600-31M	1	ROD END BLOCK	APE	A600-31M
14	A600-31A	1	CYLINDER BARREL	APE	A600-31A
15	A600-32	1	CYLINDER ROD PISTON	APE	A600-32
16	2404-L-06-04	2	EXTEND ADAPTOR FITTING	BRENNAN	---
17	A600-28	1	BLIND END BLOCK	APE	A600-28
18	SHD1250	1	ROD WIPER	PARKER	---
19	12501250-250	1	ROD SEAL w/ BACKUP	PARKER	---
20	BIN STOCK	1	ROD WEAR BAND 1/8" X 1/2"	PARKER	---
21	BIN STOCK	2	PISTON SEAL w/ BACKUP	PARKER	---
22	BIN STOCK	1	O-RING	PARKER	---
23	BIN STOCK	1	PISTON WEAR BAND	PARKER	---
24	BIN STOCK	1	O-RING	PARKER	---



V. PARTS LISTS (Continued...)

V-9 . DIN Valve Bleed Check / Orifice

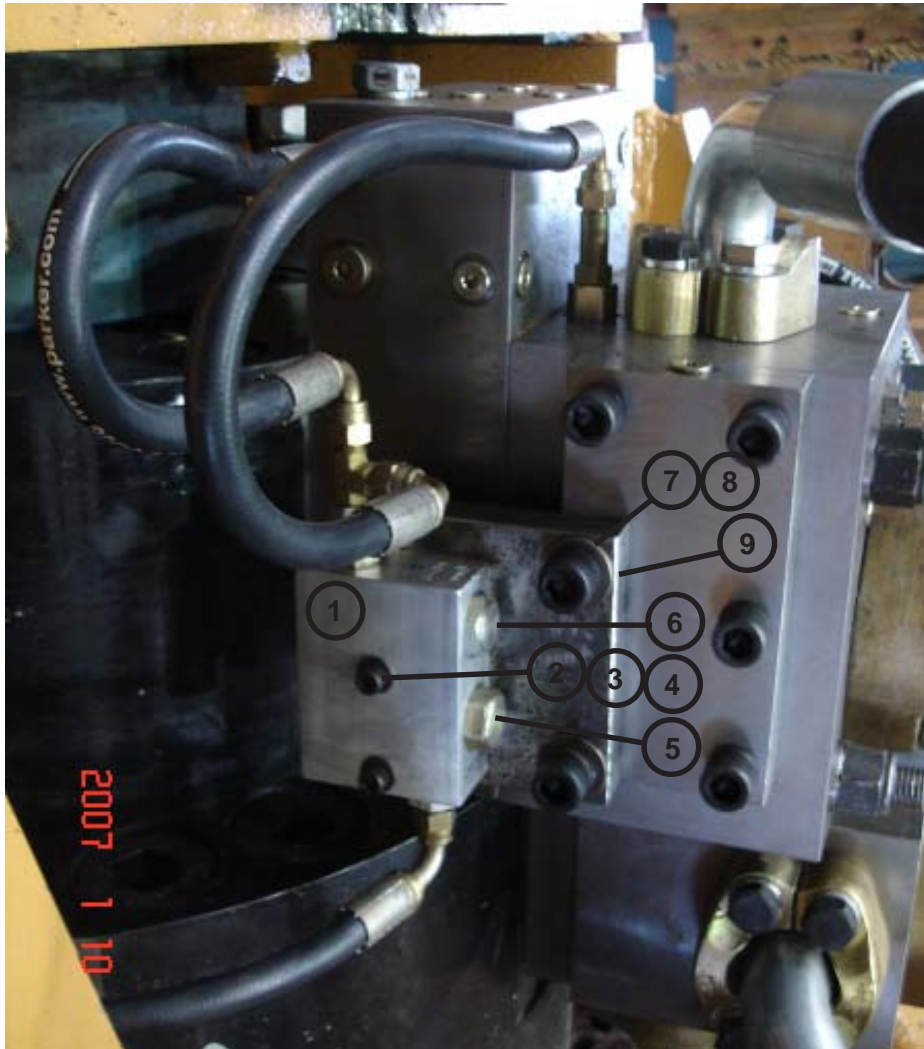

Figure 5-K. DIN Valve Bleed Check / Orifice

ITEM	P/N	QTY	DESCRIPTION	MFG./VENDOR	DWG
1	BMC1112	1	CARTRIDGE HOUSING	SPENCER	---
2	BIN STOCK	2	3/8"-16 X 3.00 SHCS	HI-STRENGTH	---
3	BIN STOCK	2	3/8" FLAT WASHER	HI-STRENGTH	---
4	BIN STOCK	2	3/8"-16 NYLOCK NUT	HI-STRENGTH	---
5	CVH103P O519	1	CHECK VALVE	PARKER	---
6	20301	1	PLUG - DRILLED TO 0.13"	PARKER	---
7	BIN STOCK	2	5/8"-11 X 3.50 SHCS	HI-STRENGTH	---
8	BIN STOCK	2	5/8" FLAT WASHER	HI-STRENGTH	---
9	A-1755	1	CV/ORIFICE BRACKET	APE	A-1755



OPERATION / MAINTENANCE MANUAL

MODEL 750U HYDRAULIC IMPACT HAMMER

7032 SOUTH 196th - KENT, WA 98032 - (800) 248-8498 / FAX (253) 872-8710

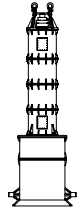

VI. MAINTENANCE & TROUBLESHOOTING

The 750 HIH is designed with simplicity of operation and maintenance in mind. However, proper daily and periodic inspection and maintenance is necessary to keep the hammer functioning properly.

Daily Maintenance and Inspection:

1. Grease the ram guides.
2. Grease stroke sled guides (inside hammer) and cycle the sled.
3. Grease striker plate housing.
4. Grease trip valve cam.
5. Systematically inspect hammer for loose bolts, hoses & fittings.
6. Operate hammer correctly per instructions and keep close track of operating temperature.

Troubleshooting:

1. Make sure stroke lever arm depresses cable (inside hammer). If not, take corrective action. Check sheaves, pins, bolts, cable. Adjust or replace as necessary.
2. Check cable for proper lockdown.
3. Manually depress lever arm fully. Make sure cam actuates the trip valve. If not, check the adjustment of the cam.
4. Allow stroke lever arm to go slack. Turn the cable adjustment nut so that valve roller is centered in cam valley.
5. Hold lever arm down, and make sure the cam depresses the roller by 7/16".
6. Check trip valve. Make sure it is securely mounted.
7. Make sure trip valve is properly adjusted with respect to placement and plunger movement.
8. Check hoses on trip valve. Make sure they are tight with no leaks.
9. Check all hoses and fittings on spool valve - make sure they are all tight with no leaks.
10. Make sure the stroke control cylinder functions correctly.
11. Clamp Open / Close operates the stroke control, and is slaved to the ground indicator.
12. Make sure that all of the hoses are filled and that the fittings are tight. Leaky hoses could cause inconsistent operation and bleed down of control cylinder.
13. Inspect spool valve, by removing the end plate and/or spring housing. Slowly remove the cap screws. Spring is under compression.
14. With spring removed, attempt to cycle the spool valve by hand. If it will not move, gently tap it with wood / rubber mallet. Free the spool and inspect spool / housing for damage.
15. Replace spool carefully by inserting and rotating it very slowly. It should not bind.
16. Check hoses on all accumulators - at both ends. Make sure hose are tight - no leaks.
17. Check bottom nut for tightness. Make sure bolts are intact & there is no thread damage.
18. Check lifting cushion for wear. Replace if necessary.
19. Check hoses at power unit. Make sure they are secure, with no leaks.
20. If hydraulic work is necessary, replace all hydraulic cartridges.