



OPERATION AND PARTS LIST MANUAL



SERIAL NUMBER:

DASH 4 HYDRAULIC IMPACT HAMMER



OPERATION / MAINTENANCE MANUAL

DASH 4 HYDRAULIC IMPACT HAMMER

7032 SOUTH 196th - KENT, WA 98032 - (800) 248-8498 / FAX (253) 872-8710



OPERATION / MAINTENANCE MANUAL

DASH 4 HYDRAULIC IMPACT HAMMER

7032 SOUTH 196th - KENT, WA 98032 - (800) 248-8498 / FAX (253) 872-8710

Hydraulic Impact Hammer Checklist Prior to Shipment

Date: _____ Sales Order Number: _____ Hammer S/N: _____

Customer: _____ Ship Date: _____

Checking the hammer:

- Removed all wire rope for insurance reasons
- Checked all bolts on lead guide rails
- Inspected all wire rope nuts
- Inspected ram for cracks
- Inspected lead guide rails and welds for cracks
- Inspected all hoses and fittings on cylinder manifold

Lower end / Drive base

- Checked retainer ring bolts
- Check grease fittings
- Checked the striker
- Checked ram connection bolts
- Removed any welding attached by pile crew
- Serial number stamped and welded with SS rod

HIH test

- Checked and cleaned quick disconnects
- Checked to make sure caps and plugs are there
- Checked all o-rings on QD's
- Put spare o-ring kit in tool box of power unit

Test Data:

- Drive pressure: _____
- Cycles per minute: _____
- Temperature of hydraulic oil at time of test: _____

Tips for the APE service technicians and pile crew:

Please clean the control panel and spray some armor all on it.

Prior to the hammer going out on rent it must look like new condition. If the paint appears bad then paint it. If the paint surface is bad then have it sand blasted. Do not allow the hammer to go out looking bad. Any bad hoses should be replaced. The most important thing is the condition of the striker and the hoses. Both should be new or in new condition.

If this unit is going to operate in cold weather then please make sure the proper oils have been used. In cold weather operations we must use a softer o-ring to handle the colder temperatures.

One manual with copy of this check out sheet

APE hard hat stickers for pile crew

APE literature on this unit plus any new information for the pile bucks to read.

The tool kit for the power unit should be listed on the "Check list for power unit" and therefore is not included with this form.

Comments:

DAILY CHECK LIST

CHECK NUTS AND BOLTS

GREASE RAM BLOCK 10 PUMPS
IN EACH GREASE FITTING

GREASE STRIKER PLATE 10 PUMPS

INSPECT ALL WELDS FOR CRACKS

CHECK HOSES FOR WEAR AND TEAR,
KINKS AND WHISKERS/BROKEN WIRES

CHECK RUBBER STOPS ON COLUMNS

Inspected by: _____

Approved by: _____

This unit owned by: _____

Final inspection completion date: _____

Branch manager final approval: _____



OPERATION / MAINTENANCE MANUAL

DASH 4 HYDRAULIC IMPACT HAMMER

7032 SOUTH 196th - KENT, WA 98032 - (800) 248-8498 / FAX (253) 872-8710

POWER UNIT CHECK LIST PRIOR TO SHIPMENT

Date: _____ Sales Order Number: _____ Power Unit S/N: _____ Ship Date: _____

Engine Hour Meter Reading: _____ Hours on Working Meter: _____ Engine Serial Number: _____

- Air cleaner removed, cleaned or replaced.....
- Tools: chain, allen, and slugging wrenches.....
- Alternator belts checked and tight
- Battery water level checked.....
- Battery terminals cleaned and tight.....
- Engine coolant level OK and anti-freeze OK
- Diesel fuel level checked
- Diesel fuel tank flushed (once per year)
- Engine oil level: OK yes Changed yes no
- Checked exhaust system including rain cap
- Hydraulic & fuel gauges checked for cracks or leaks.....
- No overspray on gauges.....
- Hydraulic pump type gear piston number of sections _____
- Gear pump sizes 1" 1 1/4" 1 1/2" circle one.....
- Checked hydraulic fluid level in both tanks.....
- Checked hyd hose for vibration wear
- Checked cooler hose brackets
- Check, clean pendant and cable to look new
- Checked and set engine oil pressure switch.....
- Checked and set engine water temp switch
- Checked and set hydraulic oil temp switch.....
- Visually inspected hyd oil float switch
- Observed back pressure on hyd filter gauge
- Checked radiator hoses for leaks and wear.....
- Checked and greased all door latches
- Key lock code _____ installed keys.....
- Oiled all locks and checked lock hardware.....
- Changed fuel filters yes no
- Hydraulic oil sample taken and tested
- Set drive pressure relief valve.....
- Set clamp pressure relief valve
- Set clamp pressure switch.....
- Drained water condensation from hyd tank.....
- Engine maximum RPM checked and set
- Caps and plugs checked on quick disconnects
- Cables holding caps and plugs are OK
- Manual for power unit installed in box.....
- Decal posted on power unit near fill pump
- Diesel engine warning label posted on door
- Quick disconnect warning label posted
- APE logo painted on back of power unit.....
- Control panel cleaned and looking new.....
- Doors latched and fully shut and locked properly
- Cold weather requirements: #1 or #2 diesel

- Have you prepared this unit for cold weather
- Removed breather on Hyd band and cleaned
- Checked all bolts on Hyd pumps for tightness
- Checked pump drive lube level.....
- Installed decal showing all filters on this unit.....
- Checked for broken exhaust bolts.....

TEST RUN CHECK LIST

- Checked engine drop at Full RPM.....
- Check flow with flow meter.....
- Flow Rate _____ GPM Relief pressure setting _____
- Changed hydraulic filter.....
- Clamp Pressure relief setting(open) _____
- Pressure Switch close setting _____

LOADING EQUIPMENT CHECK LIST

Power unit should be loaded on the truck with the hydraulic tank facing the wind. This prevents rocks from striking the radiator and oil cooler. In addition, the rain cap should be duct taped to prevent rain from getting into the engine and to prevent air flow from spinning the turbo charger. Due to heat expansion, do not fill the diesel fuel tank to the top.

Power unit serial number welded on top right hand corner of power unit on control panel side. Numbers should be 3" high and performed by welder with excellent penmanship.

POWER UNIT SKID DAMAGE REPORT

Report in words. Explain in detail all damage:

Inspected by: _____

Approved by: _____

This Unit owned by APE: yes no

If Answer is YES to Question Above is GPS Unit Installed

Final Inspection Completion Date: _____

Branch Manager Final Approval: _____



OPERATION / MAINTENANCE MANUAL

DASH 4 HYDRAULIC IMPACT HAMMER

7032 SOUTH 196th - KENT, WA 98032 - (800) 248-8498 / FAX (253) 872-8710

Preface

General

This manual covers the **Model DASH 4 Hydraulic Impact Hammer**. The data provided in this manual gives the necessary information to operate and identify parts for this piece of APE equipment. The listed procedures are to be performed by qualified personnel who have an understanding of the equipment and who follow all safety precautions.

Guide to Using the Manual

1. Refer to the Table of Contents for the page location of applicable sections.
2. All weights and measurements in this manual are in both English and Metric units.
3. The manual will be revised as necessary to reflect current information.

Abbreviations

The following are abbreviations used within this manual.

lb	= Pounds	kg	= kilograms
psi	= Pounds per Square Inch	kW	= kilowatts
bar	= pressure (metric)	kip	= 1000 lbs
hp	= Horse Power	lpm	= liters per minute
gpm	= Gallons Per Minute	mm	= millimeters
rpm	= Revolutions Per Minute	T	=tons (US)
eng.	= Engine	t	= tonnes (metric)
cyl.	= Cylinder	m	= meters
mm	= Millimeter	S/N	= Serial Number
mtg.	= Mounting	P/N	= Part Number
sol.	= Solenoid	mfg.	= Manufacturer
adj.	= Adjustment	OD	= Outer Diameter
CW	= Clockwise	ID	= Inner Diameter
CCW	=Counter-Clockwise	ft	= feet
HIH	= Hydraulic Impact Hammer		



OPERATION / MAINTENANCE MANUAL

DASH 4 HYDRAULIC IMPACT HAMMER

7032 SOUTH 196th - KENT, WA 98032 - (800) 248-8498 / FAX (253) 872-8710

Table of Contents

	Page
Revision Record	ii
Hydraulic Impact Hammer Checklist Prior to Shipment	iii
Power Unit Checklist Prior to Shipment.....	iv
Preface	v
Table of Contents	vi
Safety Precautions	vii
Warranty	x
I. GENERAL INFORMATION	1-1
I-1. Hammer Specifications	1-1
I-2. General Description of DASH 4 HIH	1-2
II. PREPARING THE DASH 4 HIH HAMMER.....	2-1
II-1. Component Identification.....	2-1
II-2. Plumbing the Hoses to the Power Unit.....	2-2
II-3. Clamp Relief Valve Settings	2-3
II-4. Drive Relief Valve Setting.....	2-6
II-5. Daily Maintenance.....	2-7
III. HAMMER CONTROL.....	3-1
III-1. Hammer Control.....	3-1
IV. COMPONENT DEFINITION	
Blow Count and Pendant Layout.....	4-1
Blow Count Box Layout	4-2
Pendant Layout	4-3
Blow Count Box Electrical Schematic	4-4
Dash 4 HIH Hydraulic Schematic	4-6
V. DRIVE BASE DEFINITION	
V-1. Floating Striker Drive Base	5-1
V-2. Type "D" Drive Base.....	5-2
V-3. DB-26 or DB-32 Insert.....	5-4



OPERATION / MAINTENANCE MANUAL

DASH 4 HYDRAULIC IMPACT HAMMER

7032 SOUTH 196th - KENT, WA 98032 - (800) 248-8498 / FAX (253) 872-8710



OPERATION / MAINTENANCE MANUAL

DASH 4 HYDRAULIC IMPACT HAMMER

7032 SOUTH 196th - KENT, WA 98032 - (800) 248-8498 / FAX (253) 872-8710

Safety Precautions

This list of precautions must be followed at all times to ensure personal & equipment safety.

1. Read this manual from beginning to end before operating or working on this machine.
2. When operating in a closed area, pipe exhaust fumes outside. (**WARNING:** Breathing exhaust fumes can cause serious injury and even death.)
3. When servicing batteries, avoid any type of spark or open flame. Batteries generate explosive gases during charging. There must be proper ventilation when charging batteries.
4. Never adjust or repair the unit while it is in operation.
5. Never enter hammer housing when power unit is running.
6. Make sure the Control Panel is in the "OFF" position before starting the unit.
7. Remove all tools and electrical cords before starting the power unit.
8. Keep oily rags away from the exhaust system.
9. Never store flammable liquids near the engine.
10. Never stand under impact hammer at any time. Keep your eyes on the hammer when it is in operation. Keep a look out for loose bolts or leaking hydraulic lines.
11. Avoid pulling on hose quick disconnect fittings. Move power unit closer to work if hoses cannot reach. Do not use hoses as a tow line to tug the power unit! If a hose fails at the hydraulic couplers then it is a result of "hose tugging by the pile crew".
12. Avoid kinks in the hoses. Kinks will cut the hose safety factor by 50 percent.
13. Always wear eye and ear protection.
14. Avoid standing downwind of piles during driving. Dirt and other matter may become airborne and fall into the unprotected eye.
15. Always wear a hardhat, gloves and safety shoes.
16. Always attach safety line to pile when extracting or hoisting into position.
17. Lay hammer down in cradle when not in use.
18. Do not truck power unit with quick disconnect caps and plugs screwed on to fittings unless the caps and plugs have wire rope safety lines attached. Store in storage box under control panel.
19. Follow the daily maintenance required prior to operation.
20. Follow the start-up procedures listed in the manual for the power unit being used.
21. Start with piles in good condition.
22. Keep piles plumb with pile guide(s).
23. Start slow. Come up to speed before doing hard driving.



OPERATION / MAINTENANCE MANUAL

DASH 4 HYDRAULIC IMPACT HAMMER

7032 SOUTH 196th - KENT, WA 98032 - (800) 248-8498 / FAX (253) 872-8710



OPERATION / MAINTENANCE MANUAL

DASH 4 HYDRAULIC IMPACT HAMMER

7032 SOUTH 196th - KENT, WA 98032 - (800) 248-8498 / FAX (253) 872-8710

Warranty

American Piledriving Equipment, Inc.
STANDARD WARRANTY

American Piledriving Equipment, Inc. (APE/J&M) warrants new products sold by it to be free from defects in material or workmanship for a period of one year after the date of delivery to the first user and subject to the following conditions: APE/J&M's obligation and liability under this WARRANTY is expressly limited to repairing or replacing at APE/J&M's option, any parts which appear to APE/J&M upon inspection to have been defective in material or workmanship. Such parts shall be provided at no cost to the user, at the business establishment of APE/J&M or the authorized APE/J&M distributor of the product during regular working hours. This WARRANTY, shall not apply to component parts or accessories of products not manufactured by APE/J&M and which carry the warranty of the manufacturer thereof, or to normal maintenance (scraped and skived lube and fuel lines, worn cushion material in the drive base) or normal maintenance parts (such as fouled injectors, weakened check valve springs, damaged grease fittings caused by use over time). Replacement or repair parts installed in the product covered by this WARRANTY are warranted only for the remainder of the warranty as if such parts were original components of said product. APE/J&M makes no other warranty, expressed or implied and makes no warranty of merchantability of fitness for any particular purpose.

APE's obligation under this WARRANTY shall not include any transportation charges, costs of installation, duty, taxes or any other charges whatsoever, or any liability for direct, indirect, incidental or consequential damage or delay. If requested by APE/J&M, products or parts for which a warranty claim is made are to be returned transportation prepaid to APE/J&M. Any improper use, including operation after discovery of defective or worn parts, operation beyond rated capacity, substitution of any parts whatsoever, or parts not approved by APE/J&M or any alteration or repair by others in such manner as in APE/J&M's judgment affects the product materially and adversely, shall void this warranty.

**ANY TYPE OF WELDING ON EQUIPMENT
WILL VOID THE WARRANTY**

Refusal: Vibros: If the pile does not move one foot in 30 seconds of vibro operation (driving or pulling) at full speed. Resort to a larger vibro. APE/J&M equipment may exceed the refusal driving criteria for short periods of time as may be needed to penetrate hard soil layers or obstacles. In such cases, a heat gun is used to monitor the temperature of the bearings and related components to prevent use of the machine beyond 195 degrees F. Contact APE/J&M or your local APE/J&M distributor for special instructions when faced with refusal conditions.

Refusal: Diesel Hammers & Hydraulic Impact Hammers: Do not exceed 10 blows per inch or 120 blows per foot. In cases of setting of the pile it is permitted to increase the blow count to 250 blows per foot, but only for one foot of driving penetration. Pile inspectors should consult the APE factory for permission to exceed these limits. Failure to do so will void the warranty. This standard specification is accepted by the DFI (Deep Foundations Institute) and the PDCA (Pile Driving Contractors Association) and by all manufacturers of pile driving equipment.



OPERATION / MAINTENANCE MANUAL

DASH 4 HYDRAULIC IMPACT HAMMER

7032 SOUTH 196th - KENT, WA 98032 - (800) 248-8498 / FAX (253) 872-8710

I. GENERAL INFORMATION

I-1. Dash 4 Impact Hammer Specifications - (Table 1-A)

<p>6-4 Ram weight.....12,000 lb Maximum stroke:48 in Minimum stroke:4 in Rated energy @ max stroke:.....48,000 ft-lb Blow rate:.....30-65 per min Weight without Insert:19,500 lb Height:144 in Standard lead size:.....8" X 26" box Hydraulic hose length:150 ft</p> <p>7-4 Ram weight.....14,000 lb Maximum stroke:48 in Minimum stroke:4 in Rated energy @ max stroke:.....56,000 ft-lb Blow rate:.....30-65 per min Weight without Insert:21,500 lb Height:144 in Standard lead size:.....8" X 26" box Hydraulic hose length:150 ft</p> <p>8-4 Ram weight.....16,000 lb Maximum stroke:48 in Minimum stroke:4 in Rated energy @ max stroke:.....64,000 ft-lb Blow rate:.....30-65 per min Weight without Insert:23,800 lb Height:144 in Standard lead size:.....8" X 26" box Hydraulic hose length:150 ft</p>	<p>10-4 Ram weight.....20,000 lb Maximum stroke:48 in Minimum stroke:4 in Rated energy @ max stroke:.....80,000 ft-lb Blow rate:.....30-65 per min Weight without Insert:27,800 lb Height:144 in Standard lead size:.....8" X 26" box Hydraulic hose length:150 ft</p> <p>15-4 Ram weight.....30,000 lb Maximum stroke:48 in Minimum stroke:4 in Rated energy @ max stroke:.....120,000 ft-lb Blow rate:.....30-65 per min Weight without Insert:42,000 lb Height:175 in Standard lead size:.....8" X 32" box Hydraulic hose length:150 ft</p>
--	--

Table 1-A. Dash 4 Impact Hammer Specifications

**Dimensions may vary depending on the year and model.
Consult the factory for certifications on unit being used.**



OPERATION / MAINTENANCE MANUAL

DASH 4 HYDRAULIC IMPACT HAMMER

7032 SOUTH 196th - KENT, WA 98032 - (800) 248-8498 / FAX (253) 872-8710

I. GENERAL INFORMATION (Continued...)

I-2. General Description of Dash 4 Hydraulic Impact Hammer

The **APE Dash 4** is a variable stroke, hydraulically-operated and controlled pile driver. In addition, the hammer can be used for soil compaction, installing well casings and testing piers.

The Dash 4 operates in a range of approximately 30 to 65 cycles per minute depending on the hydraulic flow and desired stroke.

The four major parts to the Dash 4 are as follows:

- A) Hammer Frame
- B) Main Cylinder
- C) Ram
- D) Secondary Anvil

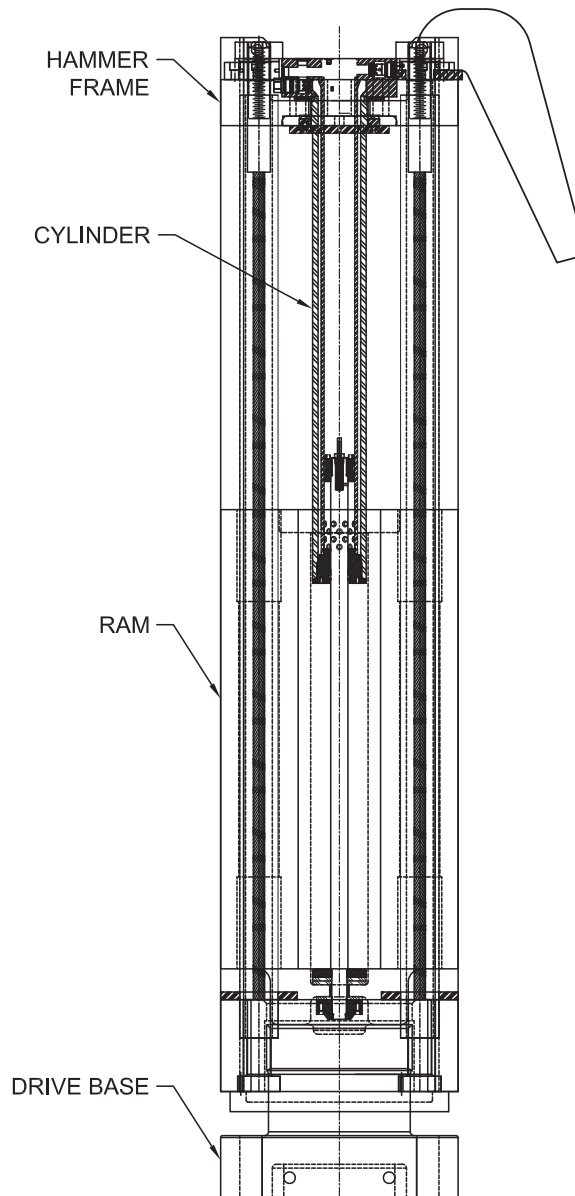

Figure 1-A. General Description of Dash 4 Impact Hammer



OPERATION / MAINTENANCE MANUAL

DASH 4 HYDRAULIC IMPACT HAMMER

7032 SOUTH 196th - KENT, WA 98032 - (800) 248-8498 / FAX (253) 872-8710





OPERATION / MAINTENANCE MANUAL

DASH 4 HYDRAULIC IMPACT HAMMER

7032 SOUTH 196th - KENT, WA 98032 - (800) 248-8498 / FAX (253) 872-8710

II. PREPARATION

II-1. Component Identification

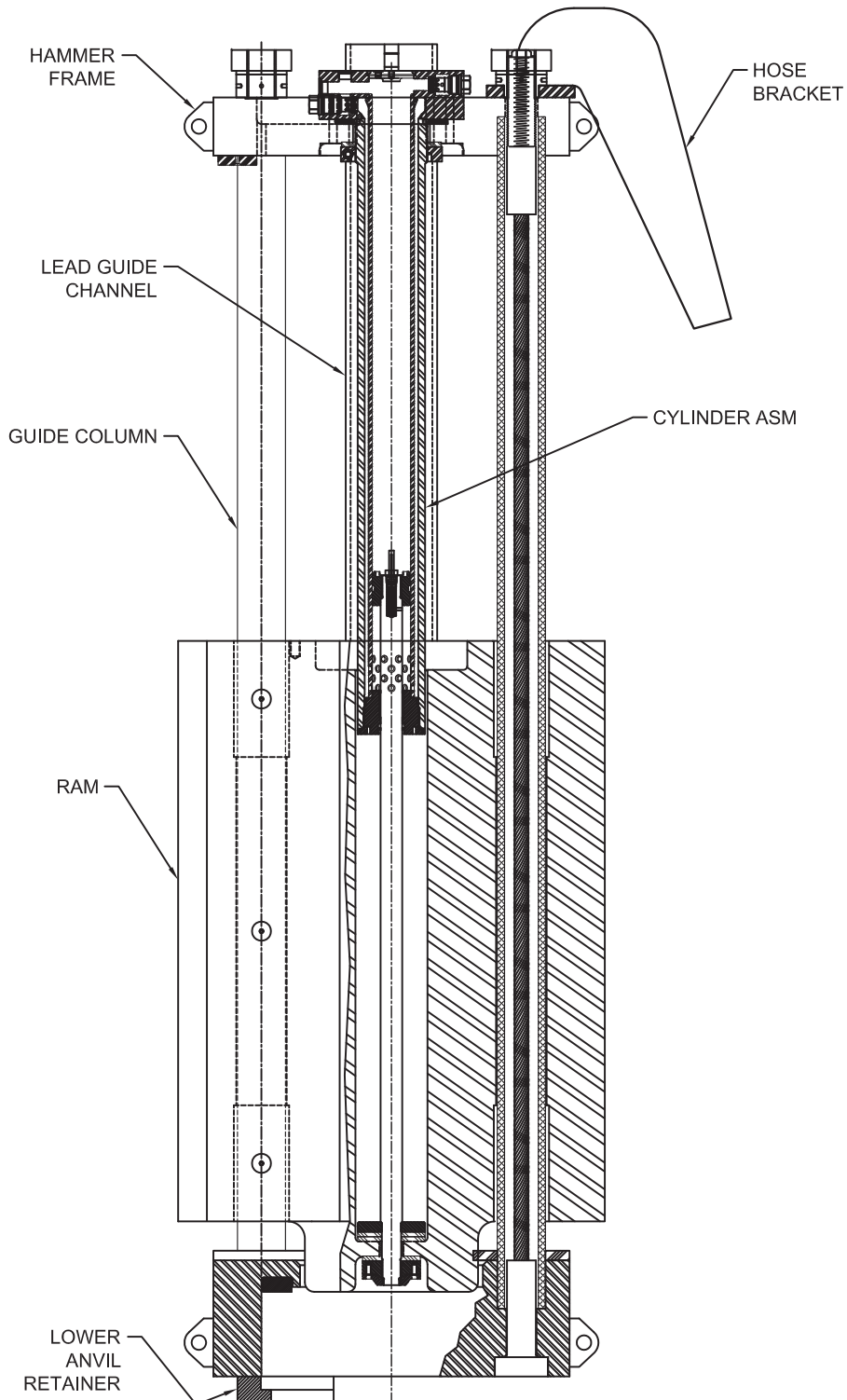

Figure 2-A. Component Identification



OPERATION / MAINTENANCE MANUAL

DASH 4 HYDRAULIC IMPACT HAMMER

7032 SOUTH 196th - KENT, WA 98032 - (800) 248-8498 / FAX (253) 872-8710

II. PREPARATION (Continued...)

II-2. Plumbing the Hoses to the Power Unit

There are three hoses leading from the hammer that must be connected to the power unit to begin operation. The hoses attach to the power unit by screwing the quick disconnect couplers onto the proper couplers of the power unit. The couplers on the power unit are mated with the couplers on the hammer so there is no chance of putting them on backwards. Please take the following steps when installing the couplers:

WARNING: TURN THE POWER UNIT OFF BEFORE INSTALLING COUPLERS

1. With the power unit OFF (engine NOT running).
2. Clean all couplers with ether if available. A clean dry cloth will also work but will require extreme care. Fittings must be spotless clean.
3. Install couplers by screwing them onto their respective counterparts. Try to avoid cross threading and maintain a straight line. Move the hose back and forth while turning coupler to aid installation effort. Push hard to get the big coupler threads started.
4. Make sure fittings are tight. If they are properly cleaned they should run up tight with just a firm hand grip. However, they should be double checked with a chain wrench.
5. Avoid overtightening.
6. If near salt water, spray with a light oil to prevent oxidation.
7. Position the Power Unit so that hammer has enough hose to reach the work. Avoid pulling too hard on hoses. Most hose failures are caused by pulling hoses off couplers.

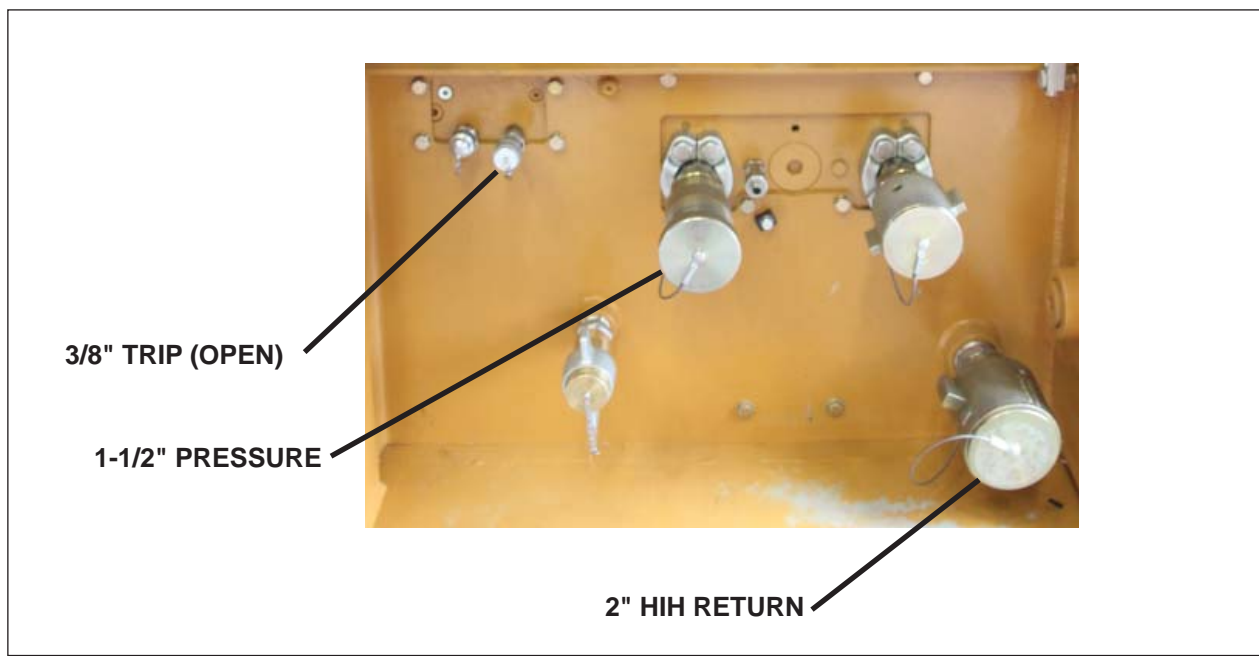

Figure 2-B. Power Unit Coupler Layout



OPERATION / MAINTENANCE MANUAL

DASH 4 HYDRAULIC IMPACT HAMMER

7032 SOUTH 196th - KENT, WA 98032 - (800) 248-8498 / FAX (253) 872-8710

II. PREPARATION (Continued...)

II-3. Clamp Relief Valve Settings Prior to Operation

The Clamp OPEN circuit is used to provide shift oil flow to the HIH from lifting and falling. This is done in the "Blow Count Box" and the settings on the pendant (described in section 3). The Dash 4 HIH requires only 2,500 psi shift pressure which is much lower than APE clamps. The Relief Valve and Pressure Switches are set by the factory. They will need to be re-set if the pressure switch is replaced.

1. Do not hook up quick disconnects. Start and warm engine . Bring to full rpm.
2. Check Clamp relief valve setting. With the LOCAL - PENDANT switch in the LOCAL position. On the Control Panel, turn the clamp switch to "OPEN" and hold it there while you read the CLAMP OPEN GAUGE on the panel. It should read 2,500 PSI. If it is not coming up to pressure, then set the relief valve (FACTORY AUTHORIZED PERSONNEL ONLY), by loosening the lock nut and turning the knob in slowly until the proper pressure is reached. Turn in (CW) to increase pressure, and out (CCW) to decrease pressure. Tighten the locknut and recheck the pressure to make sure that the setting did not move during tightening the lock nut. When the clamp switch is turned to "OPEN" and held, a small light on the solenoid is illuminated, showing that there is power to the solenoid. Otherwise, the light on the solenoid should be off.



Figure 2-C. Setting Relief Valve



OPERATION / MAINTENANCE MANUAL

DASH 4 HYDRAULIC IMPACT HAMMER

7032 SOUTH 196th - KENT, WA 98032 - (800) 248-8498 / FAX (253) 872-8710



OPERATION / MAINTENANCE MANUAL

DASH 4 HYDRAULIC IMPACT HAMMER

7032 SOUTH 196th - KENT, WA 98032 - (800) 248-8498 / FAX (253) 872-8710

II. PREPARATION (Continued...)

II-3. Clamp Relief Valve Settings Prior to Operation (Continued...)

3. Clamp pressure switch. The clamp pressure switch is not used when operating an APE HIH.



Figure 2-D. Clamp Pressure Switch



OPERATION / MAINTENANCE MANUAL

DASH 4 HYDRAULIC IMPACT HAMMER

7032 SOUTH 196th - KENT, WA 98032 - (800) 248-8498 / FAX (253) 872-8710

II. PREPARATION (Continued...)

II-4. Drive Relief Valve Settings Prior to Operation

1. With no hoses hooked up to the quick disconnects at the coupler panel. Start and warm engine. With the LOCAL - PENDANT switch in the LOCAL position. Using ONLY the switches and watching gauges at the control panel Bring to full rpm.
2. Check the drive pressure setting: Turn the drive switch to "FWD". If there is proper drive pressure the DRIVE FWD/REV gauge should read 4500 PSI. Turn the drive switch to "REV". If there is proper reverse pressure the DRIVE FWD/REV gauge should read 4500 PSI.
3. Adjust the Drive or Reverse pressure setting. (If necessary).

Set Forward Relief Pressure to 0 PSI by turning adjustment screw all the way out. (Counterclockwise) This valve is shown as item 11 in FIG (see figure 2-F.)

Start Unit and at idol shift to FWD (testing to ensure relief @ 0 PSI)

Increase RPM to Full, Set Relief to 4500 PSI (turn relief clockwise slowly) then Tighten Jam Nut

Repeat procedure if necessary in REV. The REV valve is shown as item 10 in FIG (see figure 2-F.)

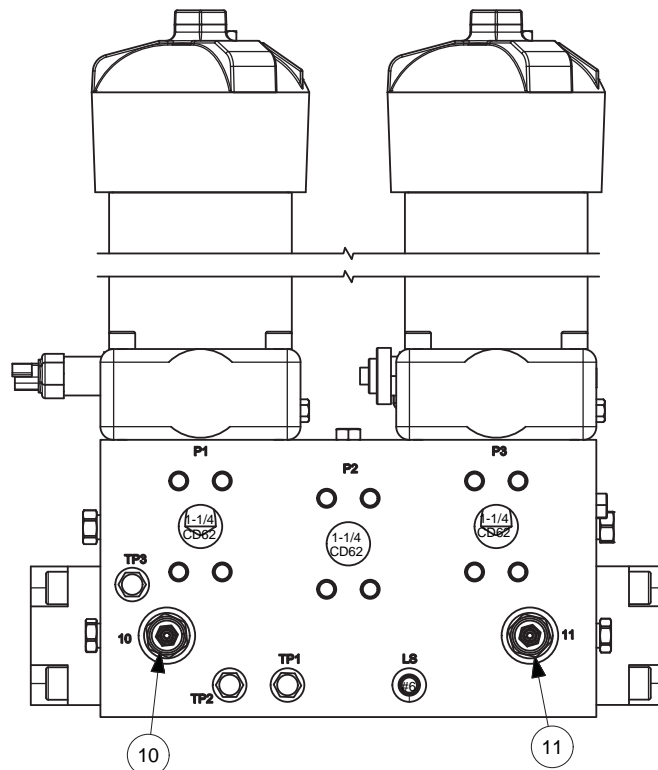

Figure 2-F. Relief Valve location



OPERATION / MAINTENANCE MANUAL

DASH 4 HYDRAULIC IMPACT HAMMER

7032 SOUTH 196th - KENT, WA 98032 - (800) 248-8498 / FAX (253) 872-8710

II. PREPARATION (Continued...)

II-5. Daily Maintenance

- Grease Guide column at all grease fittings in the ram
- Grease striker plate 20-30 shots at beginning of shift and 4 shots every 2 hours
- Grease lead guides
- Check condition of cushion
- Check ram connection cushion and bolts
- Checked all bolts on lead guide rails
- Inspected lead guide rails and welds for cracks
- Inspected all hoses and fittings on cylinder manifold
- Checked retainer ring bolts



OPERATION / MAINTENANCE MANUAL

DASH 4 HYDRAULIC IMPACT HAMMER

7032 SOUTH 196th - KENT, WA 98032 - (800) 248-8498 / FAX (253) 872-8710

III. HAMMER CONTROL

III-1. Hammer Control

The hammer control consists of a Blow Count Box and a Pendant, connected via a multi conductor cable. The Blow Count Box should be mounted to the Power Unit just below the Control Panel. The Blow count box is connected to the Control Panel via an Amphenol Plug.

1. Emergency Stop Button The Emergency stop Button is located at the very top of the pendant station. Depressing this button will kill the Power Unit Engine.



Use of the EMERGENCY STOP button will damage the engine and should only be used in the case of a real emergency.

2. Governor Switch: Turn this switch to the left "Lower" Engine RPM. Turn the switch to the right "Raise" Engine RPM.

Note: If the engine rpm is increased while the hammer is operating, the stroke will increase. Be careful.

3. Stroke Switch: This switch is the primary control, regulating the time of the ram stroke. Turning the switch all the way to the "Left" (approx 7 o'clock) will produce the shortest stroke. Turning the switch all the way to the "Right" (approx 5 o'clock) will produce the longest stroke. Until the operator is really familiar with the hammer's operational characteristics, the hammer should be started with a short stroke setting, then increased after the hammer is operating.

Note: If the engine rpm is increased while the hammer is operating, the stroke will increase. Be careful.

Note: The setting for a 4 ft drop, should be about .55 seconds.

- 4 Dwell Timer Switch: It's function is to regulate dwell time between ram impact and the beginning of the next lift cycle. Turning the switch all the way to the "Left" (approx 7 o'clock) will produce the shortest dwell. Turning the switch all the way to the "Right" (approx 5 o'clock) will produce the longest dwell. Until the operator is really familiar with the hammer's operational characteristics, the hammer should be started with a long Dwell setting, then decreased after the hammer is operating. This setting is very important!



Allow enough time for the ram to come to rest before the lifting cycle starts again. When the dwell time is too short the ram can be "caught" creating far too much hydraulic pressure in the cylinder. We never want to "catch" the falling ram.



OPERATION / MAINTENANCE MANUAL

DASH 4 HYDRAULIC IMPACT HAMMER

7032 SOUTH 196th - KENT, WA 98032 - (800) 248-8498 / FAX (253) 872-8710

III. HAMMER CONTROL (Continued...)

III-1. Hammer Control (continued)

5. Hammer Switch: Turning this switch to "Hand" for intermittent stroke control. Turning this switch to the "Auto" will allow continuous use.

Note: The engine can not be started if this switch in either Hand or Auto position. it must be in the middle "OFF" position.

6. Cycle button: With Hammer switch in Hand position pushing and holding the cycle button will raise the ram until the button is released. When this button is released the ram will immediately fall. With the Hammer switch in the Auto position pushing the cycle button will start and allow the hammer to run continuously. To stop the hammer turn the hammer switch to "OFF".



OPERATION / MAINTENANCE MANUAL

DASH 4 HYDRAULIC IMPACT HAMMER

7032 SOUTH 196th - KENT, WA 98032 - (800) 248-8498 / FAX (253) 872-8710

IV. COMPONENT DEFINITION

IV-1. Blow Count and Pendant Layout

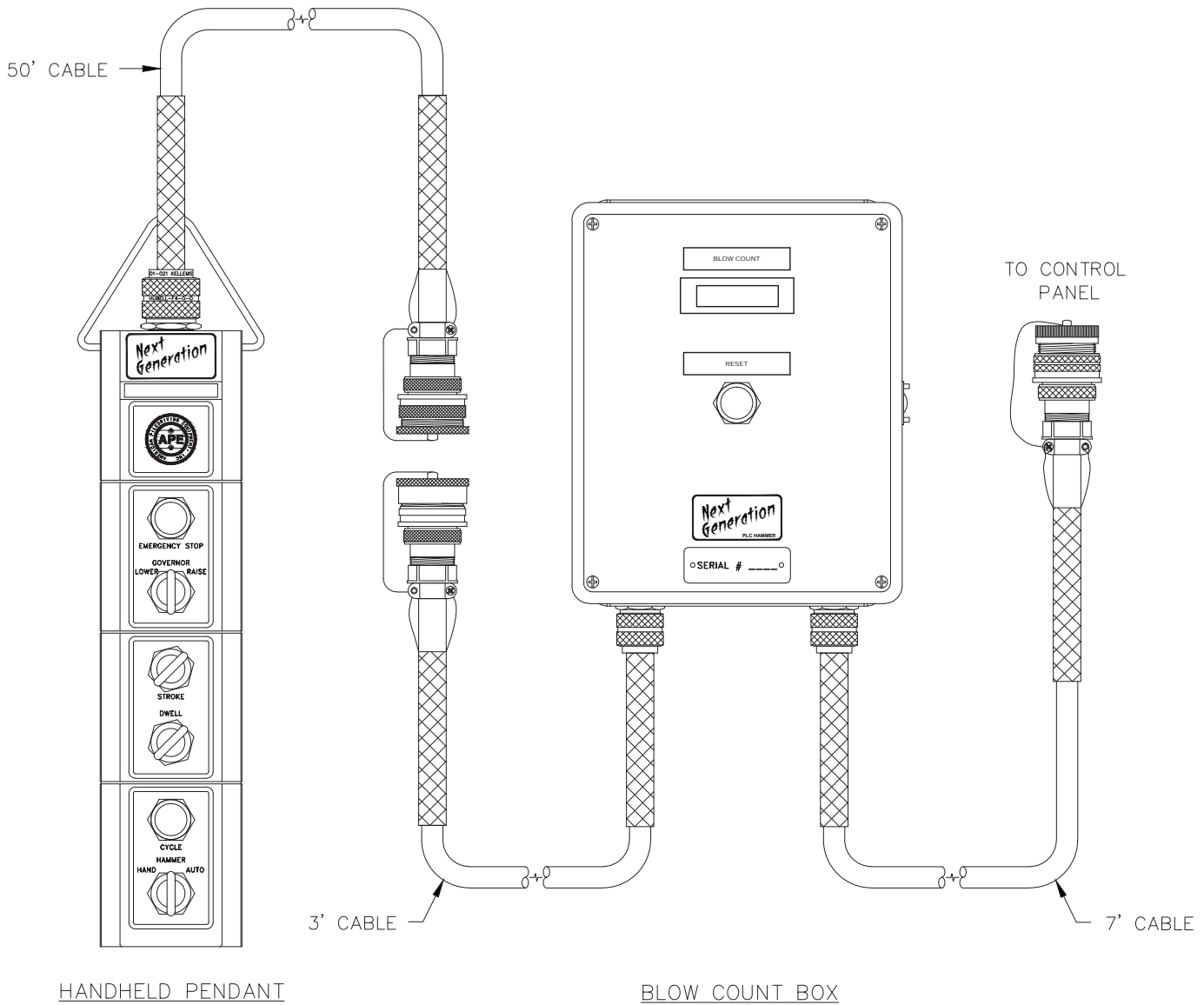

Figure 4-A Blow Count Box and Pendant



OPERATION / MAINTENANCE MANUAL

DASH 4 HYDRAULIC IMPACT HAMMER

7032 SOUTH 196th - KENT, WA 98032 - (800) 248-8498 / FAX (253) 872-8710

IV. COMPONENT DEFINITION

IV-2. Blow Count Box Layout

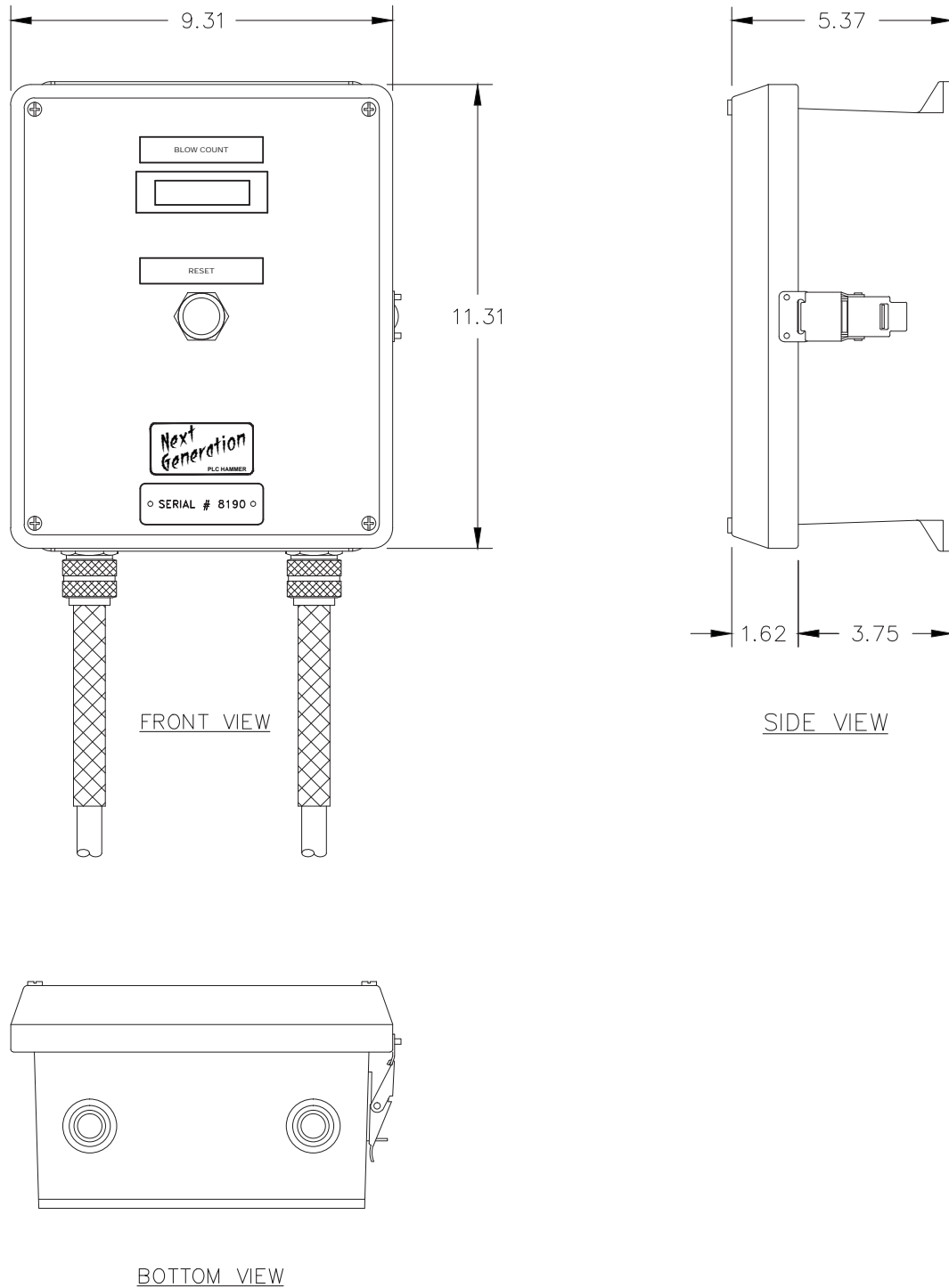

Figure 4-B Blow Count Box



OPERATION / MAINTENANCE MANUAL

DASH 4 HYDRAULIC IMPACT HAMMER

7032 SOUTH 196th - KENT, WA 98032 - (800) 248-8498 / FAX (253) 872-8710

IV. COMPONENT DEFINITION

IV-3. Pendant Layout

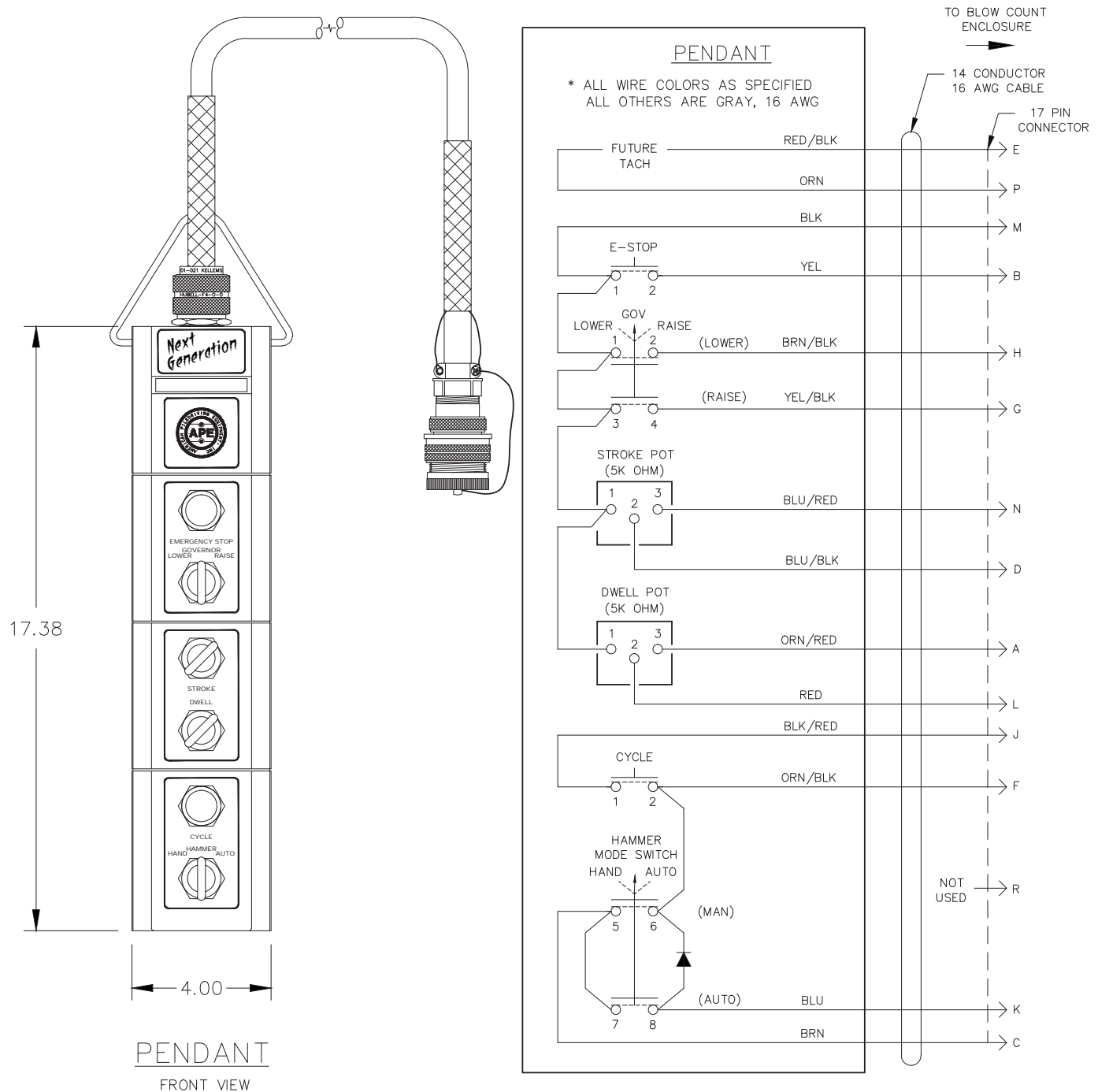

Figure 4-C Pendant



OPERATION / MAINTENANCE MANUAL

DASH 4 HYDRAULIC IMPACT HAMMER

7032 SOUTH 196th - KENT, WA 98032 - (800) 248-8498 / FAX (253) 872-8710

IV. COMPONENT DEFINITION

IV-4. Blow Count Box Electrical Schematic

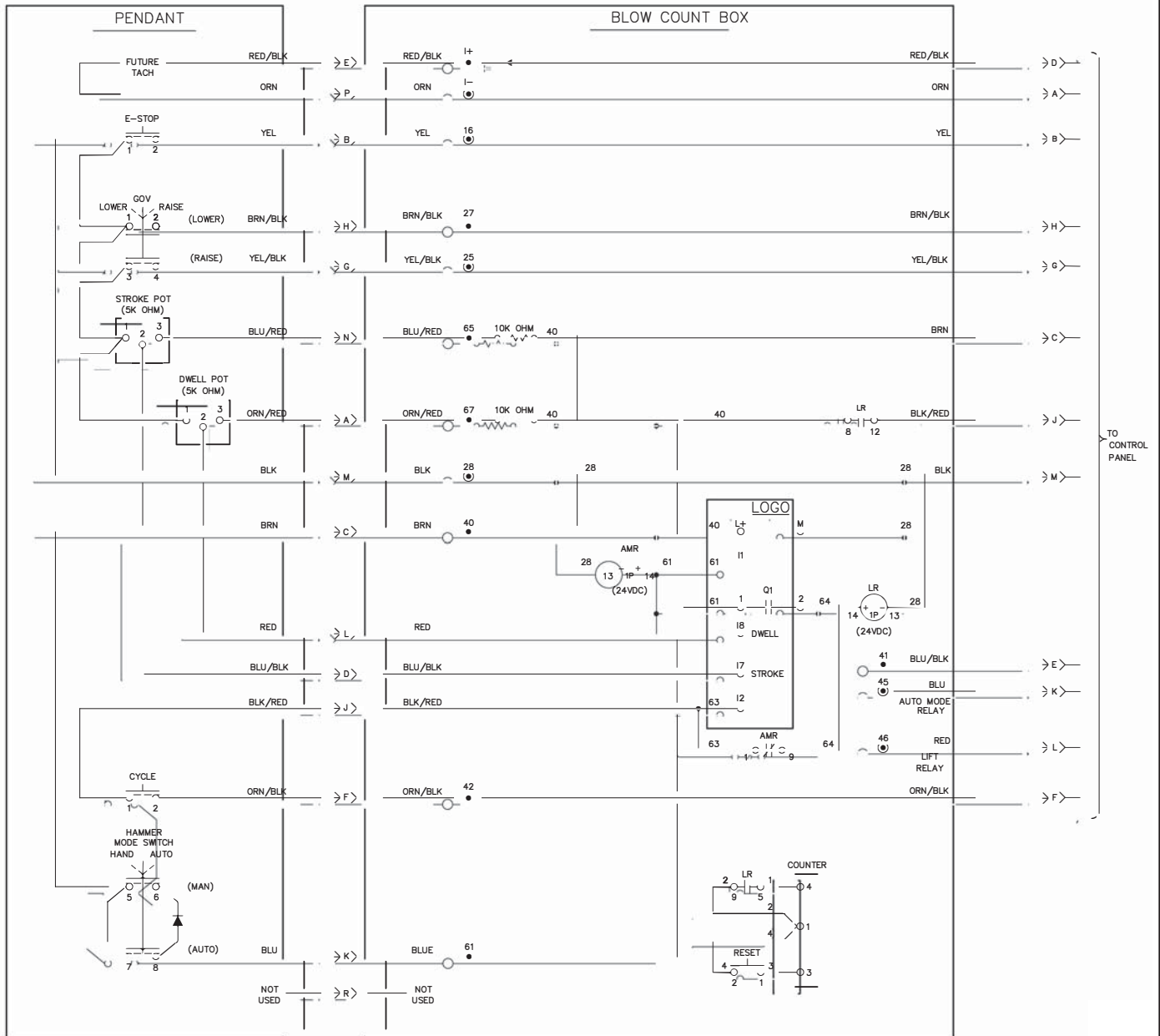

Figure 4-D Blow Count Box and Pendant Schematic



OPERATION / MAINTENANCE MANUAL

DASH 4 HYDRAULIC IMPACT HAMMER

7032 SOUTH 196th - KENT, WA 98032 - (800) 248-8498 / FAX (253) 872-8710



OPERATION / MAINTENANCE MANUAL

DASH 4 HYDRAULIC IMPACT HAMMER

7032 SOUTH 196th - KENT, WA 98032 - (800) 248-8498 / FAX (253) 872-8710

IV. COMPONENT DEFINITION

IV-5. Dash 4 HIH Hydraulic Schematic

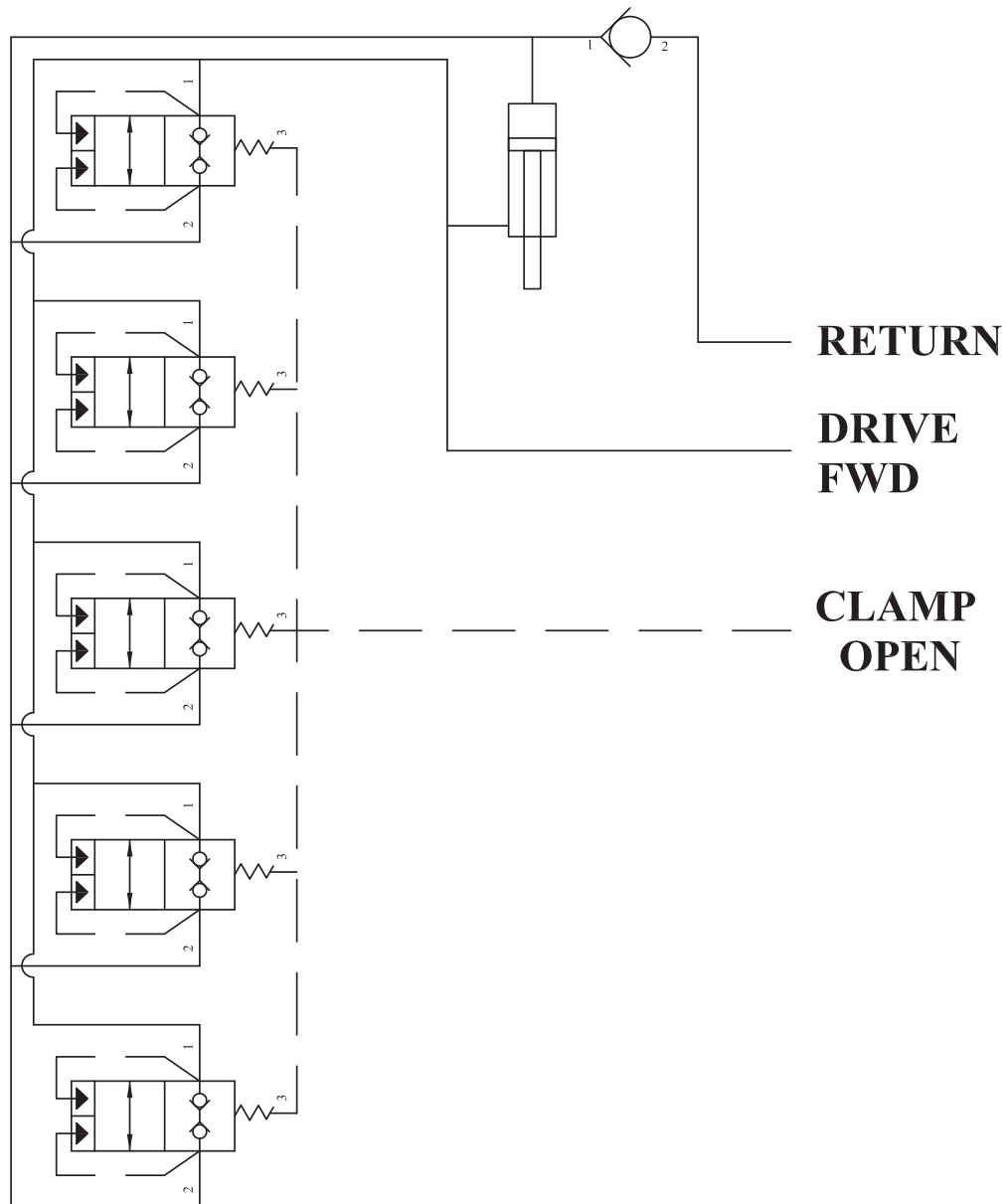

Figure 4-E Dash 4 HIH Hydraulic Schematic



OPERATION / MAINTENANCE MANUAL

DASH 4 HYDRAULIC IMPACT HAMMER

7032 SOUTH 196th - KENT, WA 98032 - (800) 248-8498 / FAX (253) 872-8710

V. DRIVE BASE DEFINITION

V-1. Floating Striker Drive Base

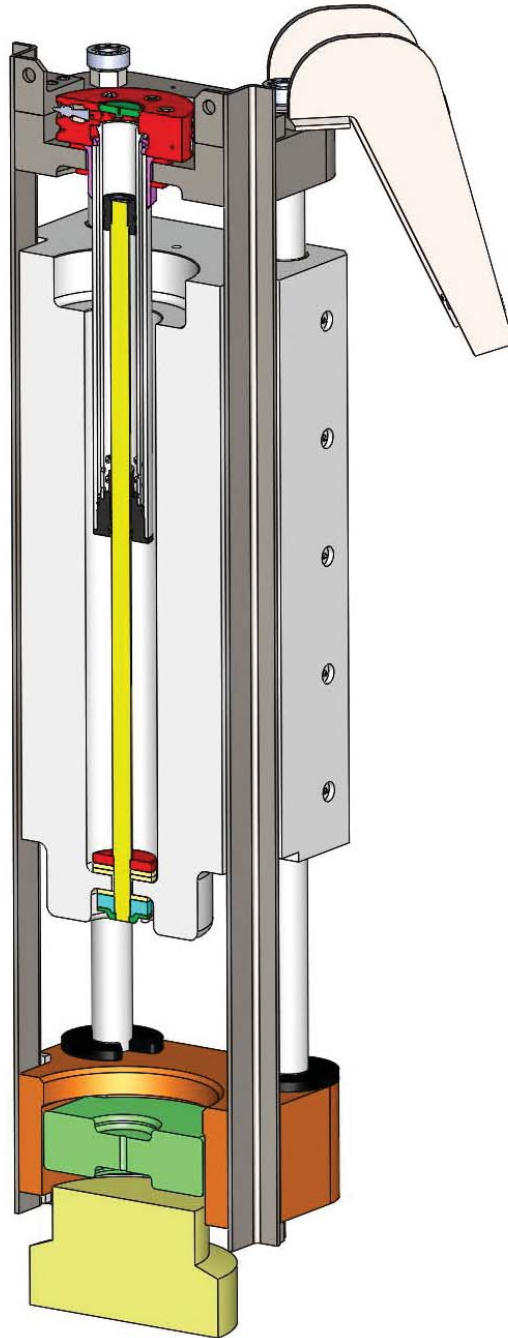

Figure 5-A Drive Base



OPERATION / MAINTENANCE MANUAL

DASH 4 HYDRAULIC IMPACT HAMMER

7032 SOUTH 196th - KENT, WA 98032 - (800) 248-8498 / FAX (253) 872-8710

V. DRIVE BASE DEFINITION

V-2. Type "D" Drive Base

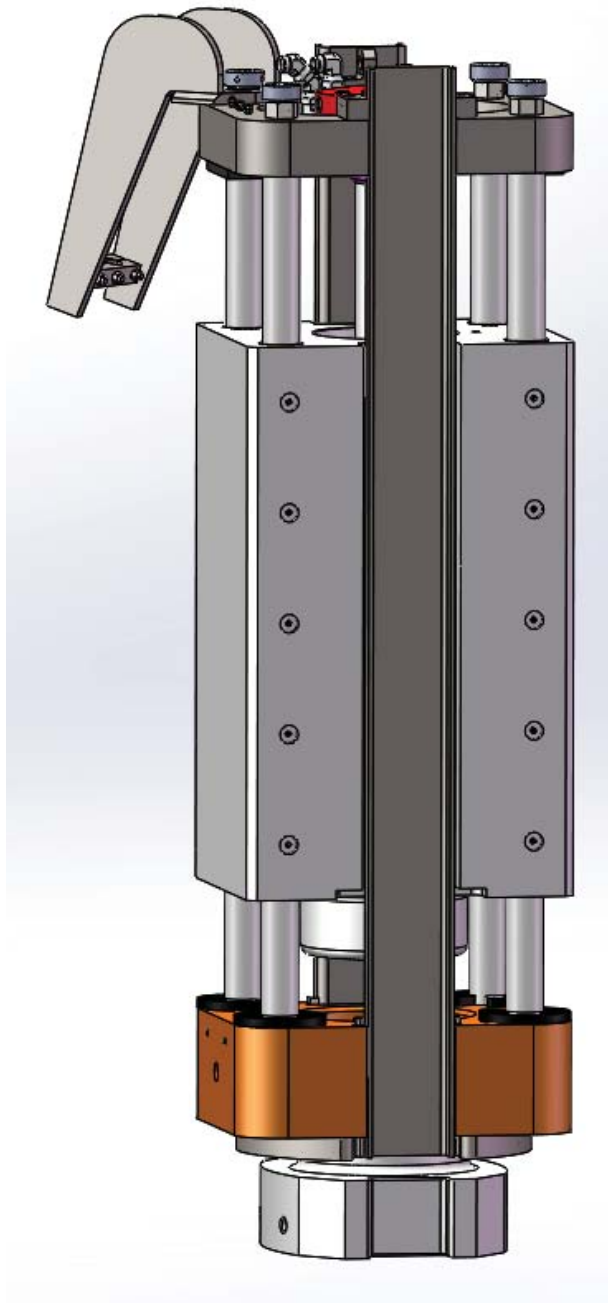

Figure 5-B Direct Drive Striker Drive Base



OPERATION / MAINTENANCE MANUAL

DASH 4 HYDRAULIC IMPACT HAMMER

7032 SOUTH 196th - KENT, WA 98032 - (800) 248-8498 / FAX (253) 872-8710

V. DRIVE BASE DEFINITION

V-1. Type "D" Drive Base

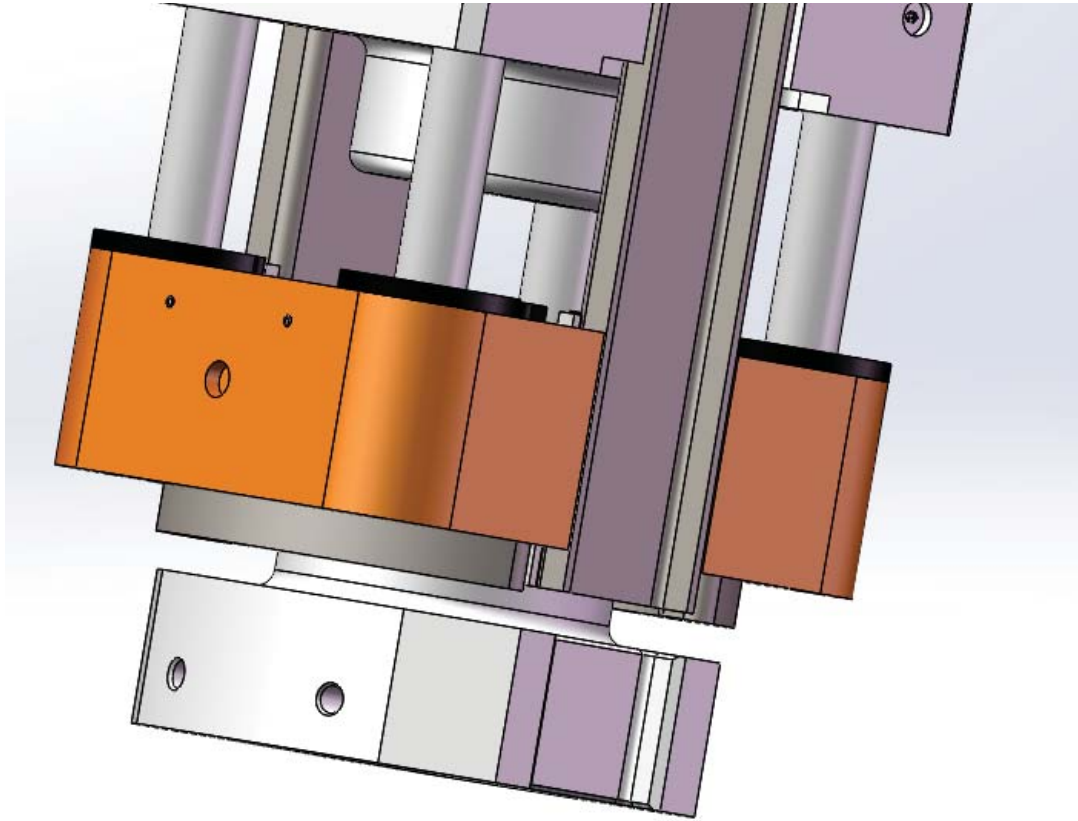

Figure 5-C Direct Drive Striker Drive Base

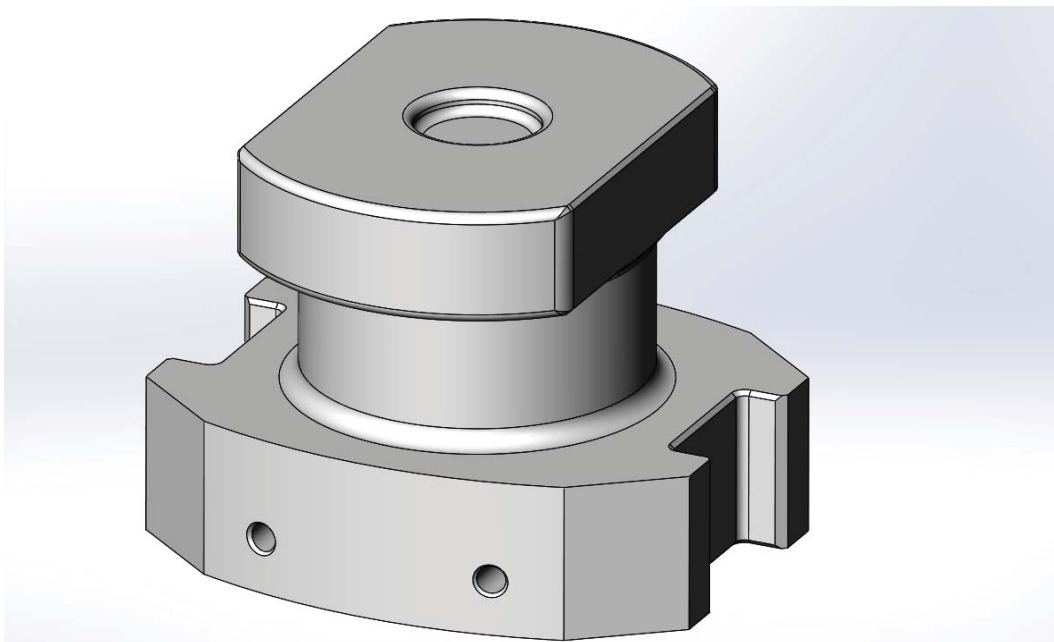

Figure 5-D Direct Drive Striker Drive Base



OPERATION / MAINTENANCE MANUAL

DASH 4 HYDRAULIC IMPACT HAMMER

7032 SOUTH 196th - KENT, WA 98032 - (800) 248-8498 / FAX (253) 872-8710

V. DRIVE BASE DEFINITION

V-3. DB-26 or DB-32 Insert

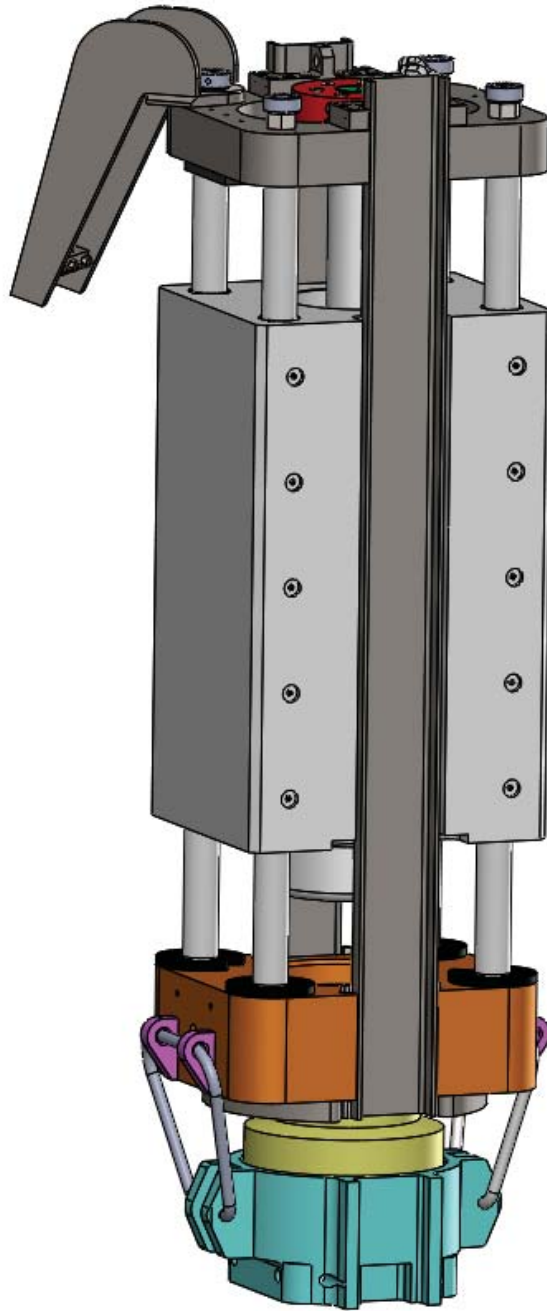

Figure 5-E DB-26 or DB-32 Insert