

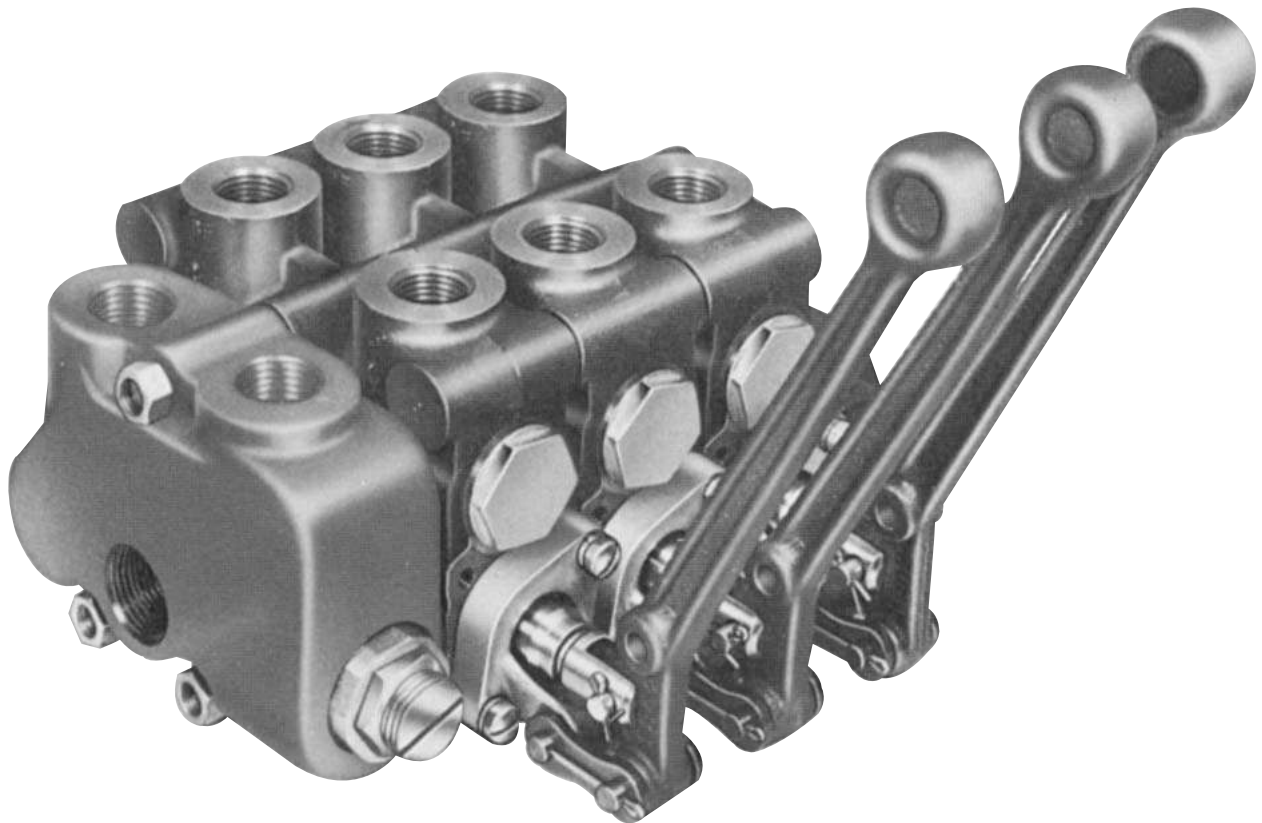

Bulletin HY14-2705-B1/US

Series V20 Directional Control Valves

Effective: October 1, 2002
Supersedes: Cat. No. GPD-1106 dated 1/91



 **WARNING**

FAILURE OR IMPROPER SELECTION OR IMPROPER USE OF THE PRODUCTS AND/OR SYSTEMS DESCRIBED HEREIN OR RELATED ITEMS CAN CAUSE DEATH, PERSONAL INJURY AND PROPERTY DAMAGE.

This document and other information from Parker Hannifin Corporation, its subsidiaries and authorized distributors provide product and/or system options for further investigation by users having technical expertise. It is important that you analyze all aspects of your application and review the information concerning the product or system in the current product catalog. Due to the variety of operating conditions and applications for these products or systems, the user, through its own analysis and testing, is solely responsible for making the final selection of the products and systems and assuring that all performance, safety and warning requirements of the application are met.

The products described herein, including without limitation, product features, specifications, designs, availability and pricing, are subject to change by Parker Hannifin Corporation and its subsidiaries at any time without notice.

Offer of Sale

The items described in this document are hereby offered for sale by Parker Hannifin Corporation, its subsidiaries or its authorized distributors. This offer and its acceptance are governed by the provisions stated in the "Offer of Sale".

CONTENTS

GENERAL INFORMATION

	PAGE NO.
INTRODUCTION	5
FEATURES	5
SELECTING A VALVE	6
HYDRAULIC CIRCUITS	8
INLET AND OUTLET COVERS	10
MAIN SYSTEM RELIEF VALVES	10
WORK SECTIONS	12
SPOOL VARIATIONS	13
SPOOL ACTION OPTIONS	14
HANDLE-END OPTIONS	20
SPECIFYING GRESEN SECTIONAL BODY	
DIRECTIONAL CONTROL VALVES	22

OPEN CENTER VALVE ASSEMBLIES, Models V20P, V20T, V20PT and V20S

FEATURES	23
SPECIFICATIONS	23
INLET COVERS	23
OUTLET COVERS	25
WORK PORT RELIEFS, CHECKS AND RESTRICTORS	28
MID-INLET CONVERSION SECTIONS	32
ORDERING OPTIONS FOR MODEL V20P WORK SECTIONS	34
ORDERING OPTIONS FOR MODEL V20T WORK SECTIONS	36
ORDERING OPTIONS FOR MODEL V20S WORK SECTIONS	38
PRESSURE DROP CURVES	40
DIMENSIONAL DRAWING	48

CLOSED CENTER VALVE ASSEMBLIES, Models V20C and V20LS

APPLICATIONS	49
FEATURES	49
SPECIFICATIONS	49
SECTIONAL VIEW	50
VALVE METERING	50
INLET COVER	50
OUTLET COVER	50
SPOOL ACTION OPTIONS AND HANDLE END OPTIONS	51
WORK PORT OPTIONS	51
PRESSURE DROP CURVES	52
DIMENSIONAL DRAWING	53

ORDERING

CONDENSED TABLE OF OPTIONS FOR COMPLETE VALVE ASSEMBLIES	54
ORDER FORM	55
WARRANTY	56

GRESEN®

V20 VALVE ASSEMBLY WITH TWO HYDRAULIC REMOTE SPOOL ACTUATORS AND ONE MANUALLY CONTROLLED SECTION.

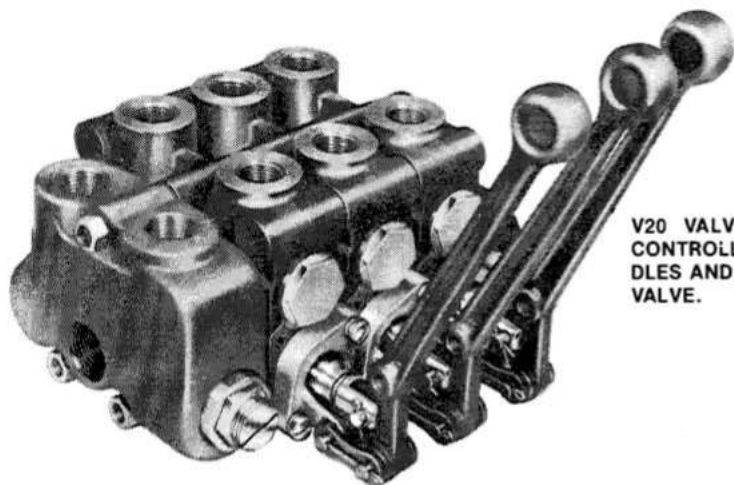
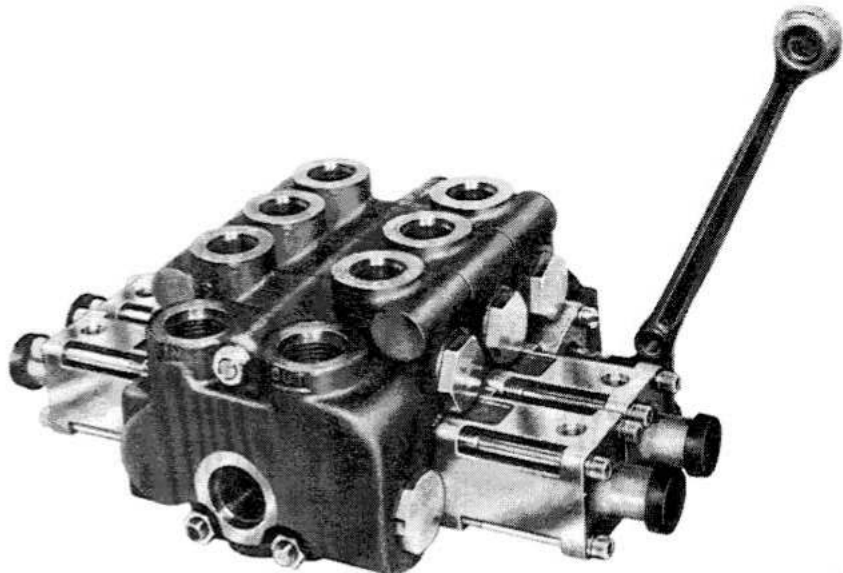

V20 VALVE ASSEMBLY, MANUALLY CONTROLLED WITH VERTICAL HANDLES AND ADJUSTABLE MAIN RELIEF VALVE.

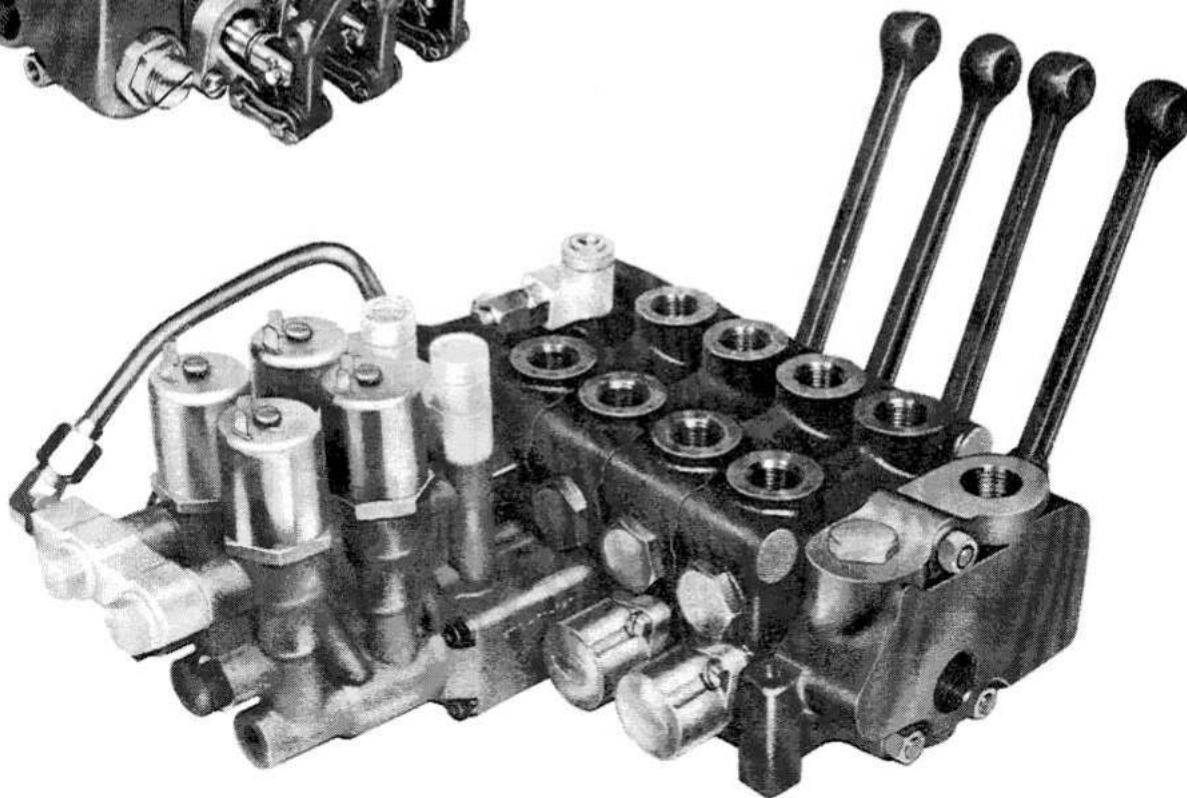

V20 VALVE ASSEMBLY WITH TWO SOLENOID CONTROLLED SECTIONS AND TWO MANUALLY CONTROLLED SECTIONS.

INTRODUCTION

Directional Control Valves . . . start, stop and direct fluid flow. They control extension and retraction of cylinders, rotation of fluid motors and actuators, and sequence other circuit operations.

Gresen offers two basic types of body designs . . . the Monoblock which has all component parts in one single casting . . . and the Sectional Body design.

Sectional Body Valves . . . consist of one or more complete work sections with end covers. The entire assembly is bolted together to form a complete Sectional Body Directional Control Valve. A variety of work sections, spools, and spool actions, end covers and relief combinations are available to provide the exact type of valve assembly required for any given application whether mobile, industrial or agricultural.

Gresen's Model V20 Directional Control Valve is available for parallel, tandem, combined parallel/tandem and series hydraulic circuit applications, up to 3500 PSI [242 bar] continuous operating pressure. Its new spool design has resulted in lighter spool actuating effort making its finger-tip touch and extra-fine metering characteristics ideal for back hoe, front end loader and personnel lift applications. This sensitivity also gives the design engineer a wider latitude of mechanical linkage possibilities.

Service or conversion is simple since individual sections can be added, removed or replaced in the field. Individual service or field conversion sections, rather than complete valve assemblies, can be stocked thus reducing inventories.

FEATURES

Exact Work Port Control . . . is achieved with smooth, positive metering valve spools. Spools are precisely hone-fitted to a matching work section for excellent spool-hold characteristics giving minimum load "leak down."

Built-In Safety . . . Hydraulic system and equipment protection incorporated at each work port eliminates need for any additional external plumbing. Main relief valves, work port relief valves, anti-cavitation checks and work port restrictors are available for safety, equipment protection and positive control.

Construction . . . All valve housings are made of ductile cast iron for durability and resistance to shock loads.

Spools are hard, chrome-plated for long life and resistance to corrosion. All spools are select hone-fitted for minimum internal leakage and maximum load-holding ability.

Seal Compatibility . . . All standard Gresen products utilize BUNA-N seals which are compatible with petroleum base, water-in-oil emulsions, and water-glycol fluids. Phosphate ester type fire-resistant fluids will cause BUNA-N seals to swell. This swelling is not normally detrimental to static seals, but will be a problem for dynamic seals such as valve spool seals. Swelling of these seals can result in binding spools. The temperature range of BUNA-N seals is -40°F [-40°C] to $+200^{\circ}\text{F}$ [$+93^{\circ}\text{C}$] for continuous operation.

VITON seals are recommended for most applications that use phosphate-ester type fluids. VITON seals are also recommended for applications that have a continuous operating temperature of $+200^{\circ}\text{F}$ [$+93^{\circ}\text{C}$] or more. VITON seals are available for Model V20 valves.

Due to the large number of hydraulic oil manufacturers, and the increasing availability of oil under various brand names, we recommend the customer consult his fluid manufacturer regarding compatibility . . . or test to his own satisfaction.

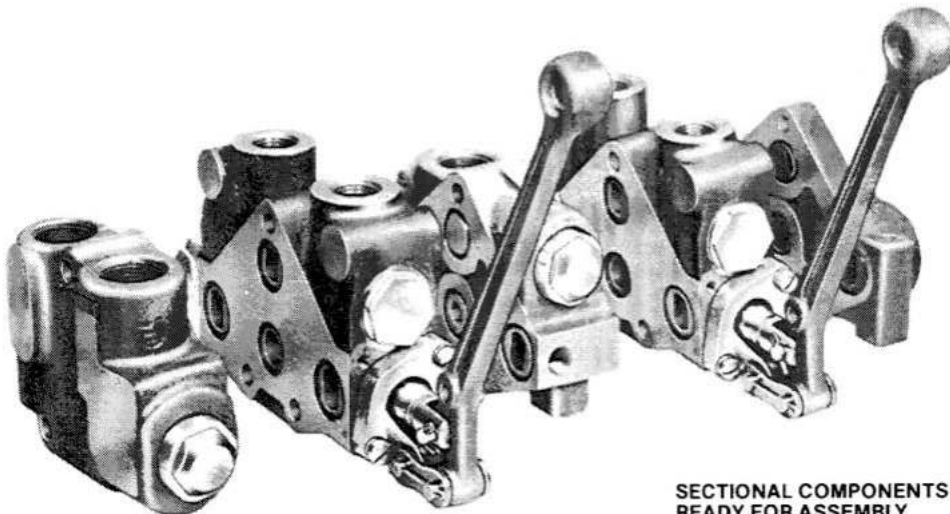

SECTIONAL COMPONENTS OF A MODEL V20 VALVE
READY FOR ASSEMBLY.

SELECTING A V20 VALVE

Gresen's V20 Directional Control Valves are offered in six different models and are grouped into two basic systems . . . **open center** and **closed center**. This catalog has grouped these two systems, each into its own section. Full description and specifications for these Valves will be found in their respective sections. To order your V20 Valves, you must first determine which system will be best for your application.

ADVANTAGES

DISADVANTAGES

OPEN CENTER SYSTEM • Refer to Page 23

Model V20P Parallel Circuit • **Model V20T** Tandem Circuit • **Model V20PT** Parallel/Tandem Circuit • **Model V20S** Series Circuit

Hydraulic oil is directed from the inlet port, thru the open center core to the outlet port of the Directional Control Valve when all spools are in the neutral position. Shifting the valve spool directs oil flow to the desired work port.

Maximum circuit pressure is limited by the main relief valve, which relieves into the exhaust core.

In a neutral position, open center systems operate at full flow and at low pressure.

- Requires simpler, fixed displacement pumps
- Lower initial cost
- Components more readily available

- Limited metering capability
- Lower overall efficiency
- Limited simultaneous operation of different functions

CLOSED CENTER SYSTEM • Refer to Page 49

Model V20C Constant Pressure-Parallel Circuit

The Model V20C work section has no open center core. Pump flow is blocked by the valve when the valve spool is in neutral position. Shifting the valve spool directs the oil flow to the desired work port.

A pump that varies the output flow and maintains a predetermined output pressure is required for this type of circuit. Closed center systems typically operate at minimum flow and at high pressure standby when the valve spool is in the neutral position. The only flow required is that which will compensate for internal losses or for other system requirements.

- Delivers only the flow required by the function
- Improved metering
- Faster operation

- Remains at high pressure when on standby
- Requires a more complex, variable displacement, pressure compensated pump

LOAD SENSING SYSTEM • Refer to Page 49

Model V20LS Load Sensing, flow and pressure compensated, parallel circuit

The Model V20LS load sensing work section is identical to the Model V20C closed center section except that internal porting has been added to allow a signal from the selected work port to be sent to the pump compensator through an external line. A flow and pressure compensated load sensing circuit permits the pump output pressure to drop to a relatively low standby pressure (150 to 250 PSI [10 to 17 bar]) when the valve spool is in the neutral position.

This system varies both pump flow and pressure with work load demand.

- Improved pump life
- Increased overall efficiency
- Increased metering capability
- More complex pump control required
- External pilot line between valve and pump compensator required.

APPLICATION EXAMPLE

Consider an application requiring a maximum flow of 20 GPM [76 litres/min] at a maximum pressure of 2500 PSI [172 bar]. To meet the requirements of the application, the pump must be able to supply maximum flow at maximum pressure when required. However, during most of its operation, it is required to deliver less than its maximum flow at less than its maximum pressure. The way in which the system responds to the reduced-load conditions and the percentage of the total operating time the system will be used under reduced-load conditions should be considered.

Functions requiring maximum system flow at maximum system pressure will all require approximately the same amount of power, assuming that system components are equivalent in size.

Functions requiring less than maximum flow and pressure best illustrate the advantages of the load sensing system. Consider a function in which a cylinder is to be extended. 1300 PSI [88 bar] is required at a metered flow rate of 9 GPM [34 litres/min].

EFFICIENCY

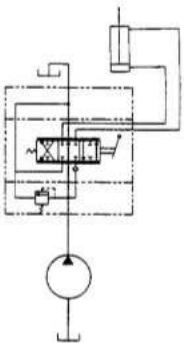

The open center system requires a fixed displacement pump capable of 20 GPM [76 litres/min] and a relief valve set at 2500 PSI [172 bar]. System pressure is determined by load resistance. Therefore, the pump delivers a full 20 GPM [76 litres/min] at 1300 PSI [88 bar] to the control valve. The control valve allows 9 GPM [34 litres/min] to be directed to the cylinder, the remaining 11 GPM [42 litres/min] is directed to the reservoir and its energy lost in the form of heat.

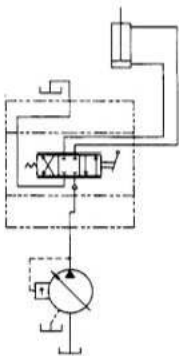
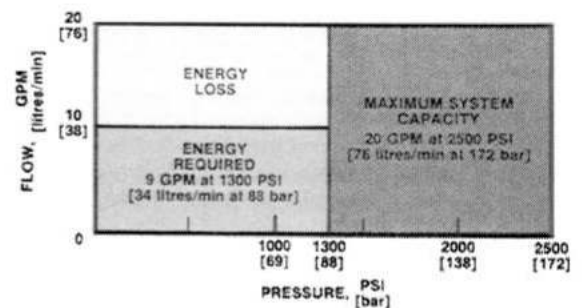

The closed center system requires a variable displacement, pressure compensated pump capable of 20 GPM [76 litres/min] with the compensator set to "destroke" the pump at 2500 PSI [172 bar]. The pump delivers only the required 9 GPM [34 litres/min] to the control valve, but at a pressure of 2500 PSI [172 bar]. Because the cylinder only requires 1300 PSI [88 bar], there is a 1200 PSI [83 bar] pressure drop through the control valve at the 9 GPM [34 litres/min] flow rate. Energy is again lost in the form of heat.

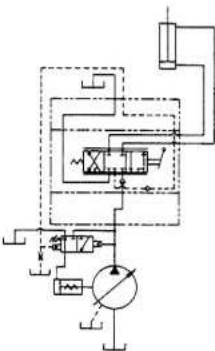
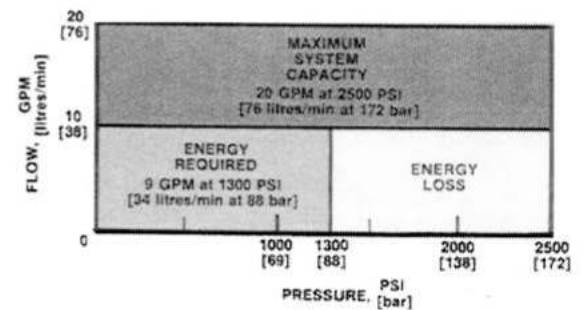

The closed center system with load sensing requires a variable-displacement, pressure compensated pump capable of 20 GPM [76 litres/min] with the compensator set to "destroke" the pump at 200 PSI [14 bar]. As the control valve is shifted to the working position, the pressure within the work port is sensed at the pump compensator. The work port pressure, 1300 PSI [88 bar], is additive to the "destroke" pressure of 200 PSI [14 bar]. Therefore, the pump delivers 9 GPM [34 litres/min] at 1500 PSI [104 bar] to the control valve. There is a 200 PSI [14 bar] pressure drop through the control valve which is lost as heat.

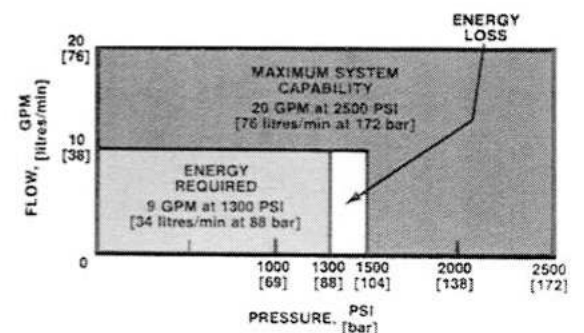

HYDRAULIC CIRCUITS

PARALLEL CIRCUITS

In a parallel circuit valve, two or more spools may be actuated at the same time and the oil will follow the path of least resistance. If a 2-spool valve is used to control two hydraulic cylinders, each with a different load, the cylinder with the lightest load will operate first if both spools are fully actuated at the same time. If the spool controlling the cylinder with the light load is metered (spool not fully actuated), then both cylinders can be operated at the same time.

When a spool is fully actuated, the open center core is blocked and oil is directed into the power core. Oil is then available to the work ports of all sections in the valve assembly.

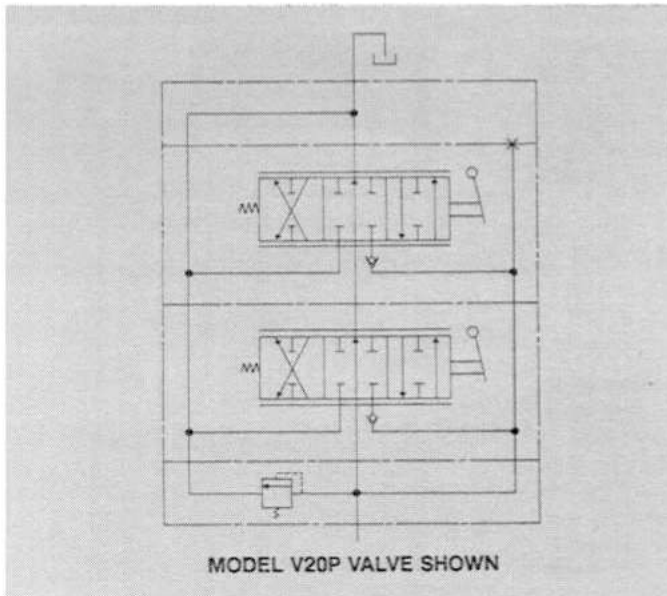

TANDEM CIRCUITS

A valve assembly made up of tandem work sections may be referred to as a priority valve or series parallel valve.

In the neutral position, oil is available to all valve sections through the open center core. When two or more valve spools are fully actuated at the same time, oil will only be available to the work ports of the upstream work section (section closest to the inlet). In a tandem valve, an upstream work section will always have priority over a downstream work section when its spool is fully actuated.

The tandem work section is very similar to the parallel work section with the following exceptions:

1. A passage within the tandem work section connects the open center core with the power core.
2. The power core is blocked on the upstream side of the tandem work section.

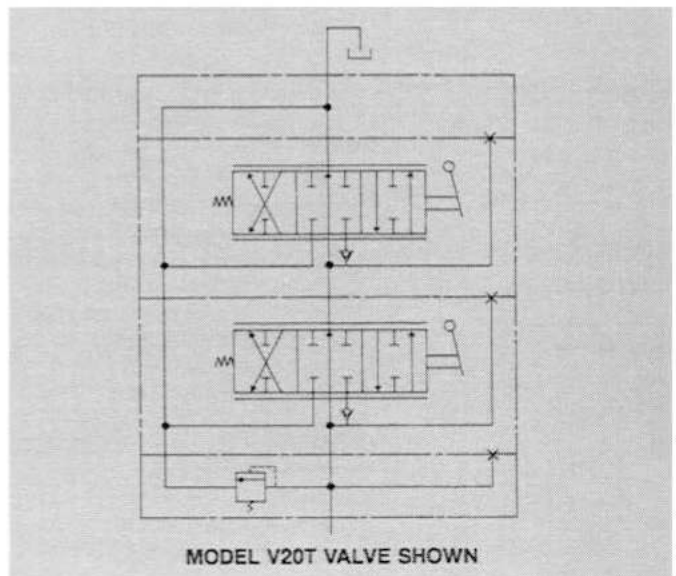

COMBINED PARALLEL/TANDEM CIRCUITS

A valve assembly may be made up of any combination of parallel and tandem sections to fit a particular application. In this type of valve assembly, the section upstream from the tandem work section has priority (the tandem section itself does not have priority). The adjacent hydraulic schematic shows a three-work-section valve: the first work section is a parallel valve; the second, a tandem valve; and the third, a parallel valve. Note that in the tandem valve work section the open center core is connected to the power core and the power core from section No. 1 is blocked at the upstream side of the tandem work section. If the spool in section No. 2 is actuated, oil will be available to its work ports. But, if the spool in section No. 1 is fully actuated at the same time, all the oil will go to the work ports of section No. 1. No oil will be available to the second or third work sections.

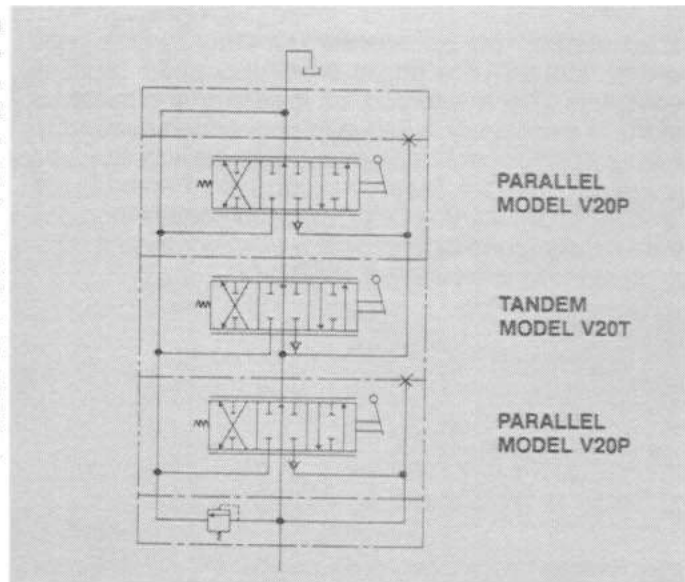

SERIES CIRCUITS

In a series circuit valve, two or more spools may be actuated at the same time. The entire flow of oil is available to each work section in sequence from inlet to outlet port through the open center core. In a 2-spool valve (both spools actuated), oil is directed from the inlet port to a work port of section No. 1. The return oil to work section No. 1 is directed back to the open center core (and not to the tank port as in a parallel valve circuit). The returning oil is then available to section No. 2.

In a series circuit, pressure is additive. That is, the sum of all pressures required by all sections cannot exceed the main relief valve setting or pump pressure capability.

With certain restrictions, Model V20S sections may be intermixed with parallel or tandem work sections in the same valve assembly. Refer to page 38 for V20S stacking sequence restrictions.

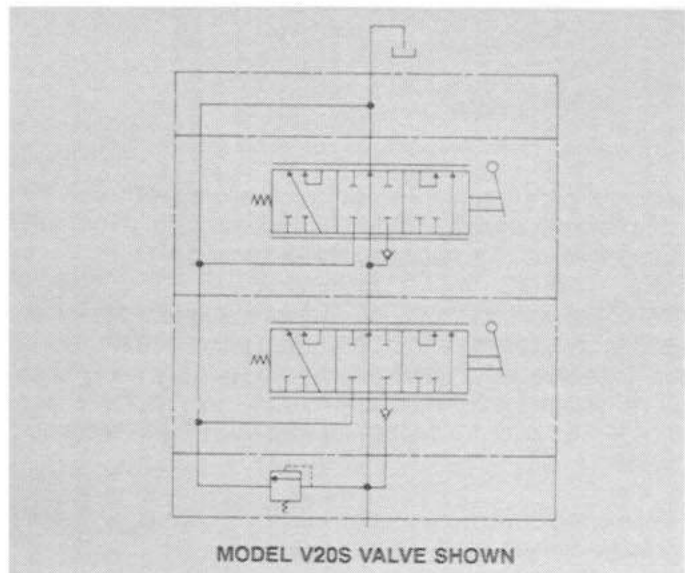

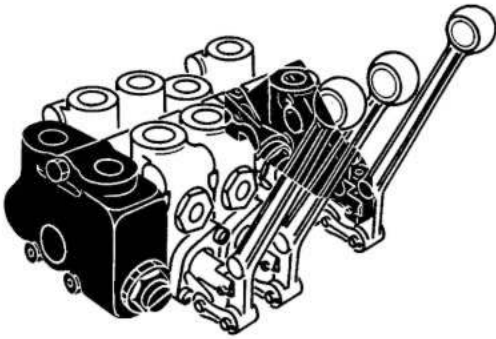

INLET COVERS and OUTLET COVERS

INLET COVERS

Inlet covers are designed to provide a variety of port sizes and locations. This permits valve assemblies to be “customized” using a minimum of external plumbing.

The outlet port may be located in either the inlet (left) cover or the outlet (right) cover. Location must be specified. If the addition of a secondary hydraulic pump is necessary, a mid-inlet conversion section for Model V20P and V20T Valves can be installed between any two work sections, providing an inlet port for the secondary pump (see page 32). Valve inlet covers are machined to accept Model WH or Model RP51 main system relief valve cartridges.

MAIN SYSTEM RELIEF VALVES

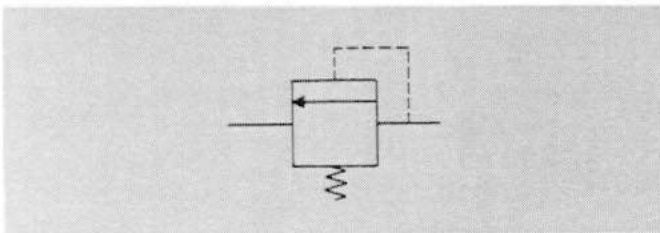

The primary function of a main system relief valve is to prevent excessive system pressures. Normally, this relief valve is installed in the inlet cover.

Relief valves for the V20 Valve Assembly are designed and fabricated in cartridge form to permit easier servicing and allow minimum interchangeability time. They feature quiet operation and are virtually trouble free and highly tolerant of foreign material in the hydraulic system.

Relief valves are available in adjustable or tamper-proof/non-adjustable configurations.

Model WH-Standard

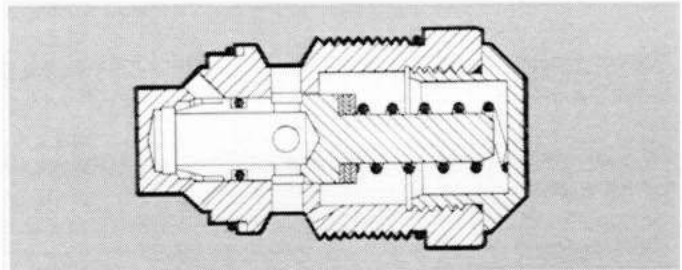

This unit is shim adjustable with shims within the spring range.

Model RP51 Optional

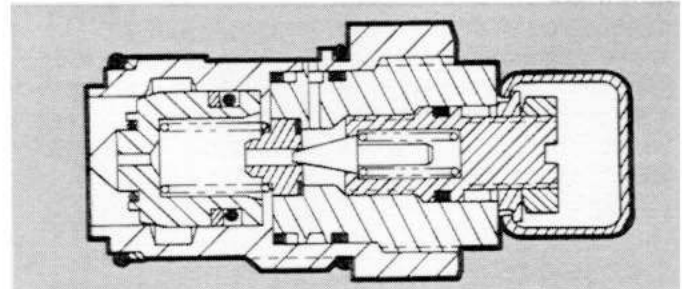

This relief valve cartridge is a pilot-operated type.

- Model RP51A — externally adjustable
- Model RP51N — tamperproof

Model WHA-Optional

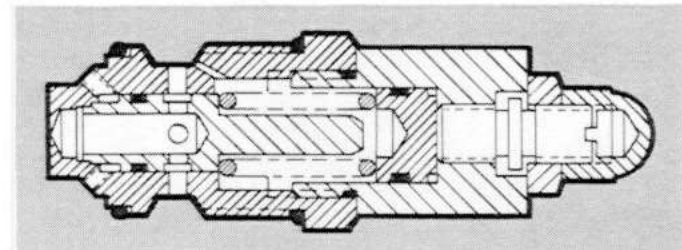

This model is easily adjustable within the spring range.

No Relief Plug, NR, Optional

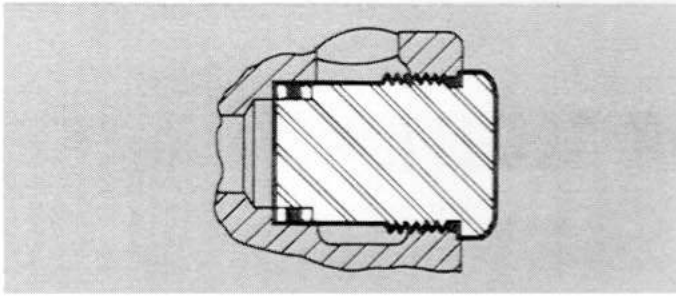

When a system main relief valve is not required, a "No Relief Plug" is installed in the inlet cover. Cover is machined to accept a Model WH or Model RP51 relief valve if field conversion is required.

2-Stage Relief Valve

A 2-stage relief option is available for Model WH main relief valve cartridges. This option will provide a second (higher) pressure setting when a pilot pressure (750 PSI minimum) is applied to an SAE 6 pilot port in the cartridge. The "high" pressure setting (3000 PSI maximum) is shim adjustable. The "low" pressure setting (500 PSI c/p minimum) is externally screw adjustable and must be specified as a "crack" pressure (1 GPM flow).

OUTLET COVERS

Although the same basic outlet covers are used in all V20 valve assemblies, the available cover options and configurations for open center, closed center, and load sensing type valves are different.

- For Models V20P, V20T, V20PT and V20S, refer to page 25.
- For Models V20C and V20LS, refer to page 50.

TYPICAL PRESSURE RANGE PERFORMANCE CURVES (150 SUS OIL) MODELS RC and WH RELIEF VALVES

INCREASING FLOW ———
DECREASING FLOW - - - - -

500 PSI TO 1350 PSI [34,50 bar to 93,15 bar] CRACK PRESSURE
1450-001 SPRING
(Not available with adjustable feature)

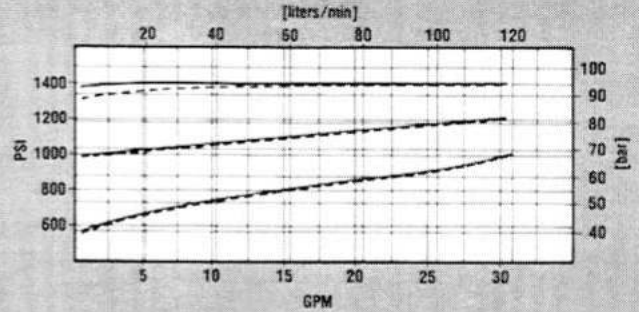

1351 PSI TO 1750 PSI [93,22 bar to 120,75 bar] CRACK PRESSURE
1864-001 SPRING

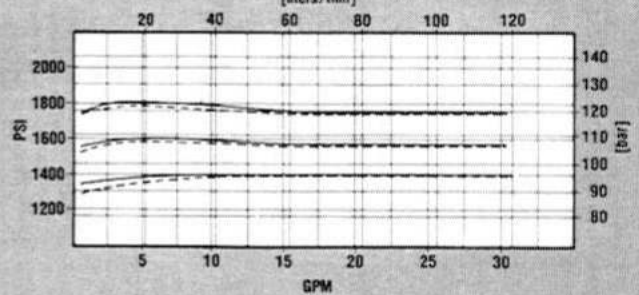

1751 PSI TO 2200 PSI [120,82 bar to 151,80 bar] CRACK PRESSURE
1451-001 SPRING

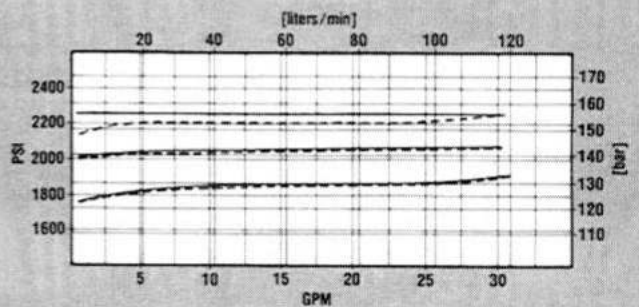

2201 PSI TO 3000 PSI [151,87 bar to 207,00 bar] CRACK PRESSURE
1865-001 SPRING

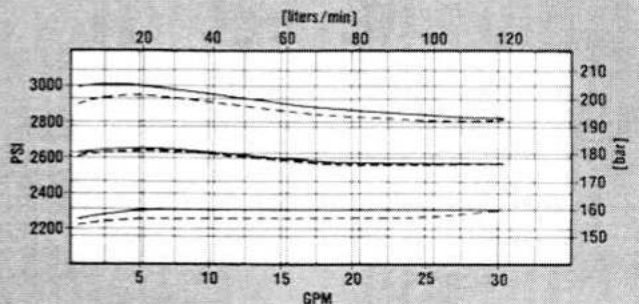

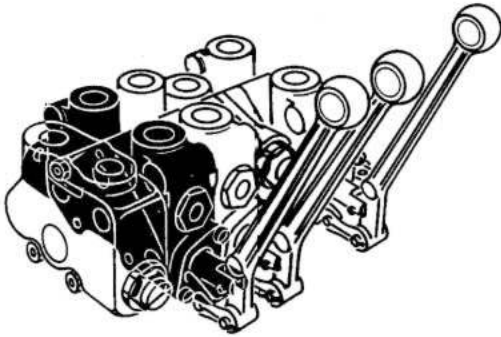

WORK SECTIONS

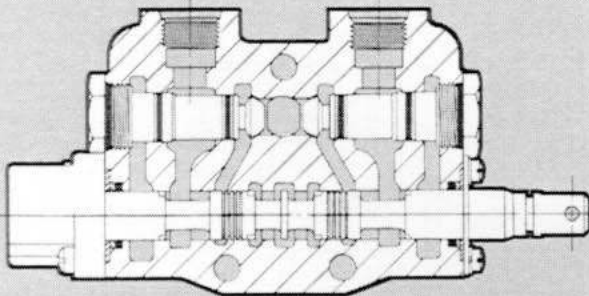

MODEL V20P WORK SECTION
(8072 HOUSING)

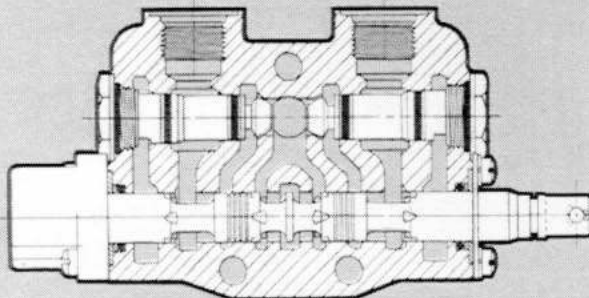

MODEL V20T WORK SECTION
(8112 HOUSING)

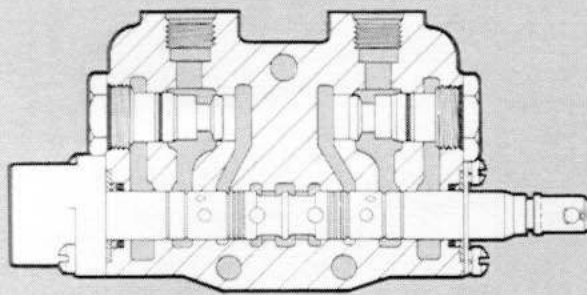

MODEL V20S WORK SECTION
(11483 HOUSING)

Work sections in Gresen's Sectional Body Directional Control Valves are precisely machined from high tensile cast iron housings.

Valve spools may be manually, hydraulically, pneumatically, mechanically or electrically operated. All valve spools are select hone-fitted at the factory for minimum internal leakage and are not field replaceable.

Five types of basic work sections are available:

- Model V20P for open center, parallel circuit applications*
- Model V20T for open center, tandem circuit applications*
- Model V20S for open center, series circuit applications
- Model V20C for closed center, parallel circuit applications
- Model 20LS load sensing, for closed center, parallel circuit applications.

A variety of spools, spool action options and work port options are available for the work sections, depending on the particular application.

*Optional 4-way work sections with reduced open center pressure drop are available for parallel (V20RP) and tandem (V20RT) circuits. These reduced pressure drop sections are interchanged with a standard V20 open center sections and use standard V20 covers. All V20 spools and options are available with these sections. A heavier spool centering spring is required with V20RP and V20RT sections.

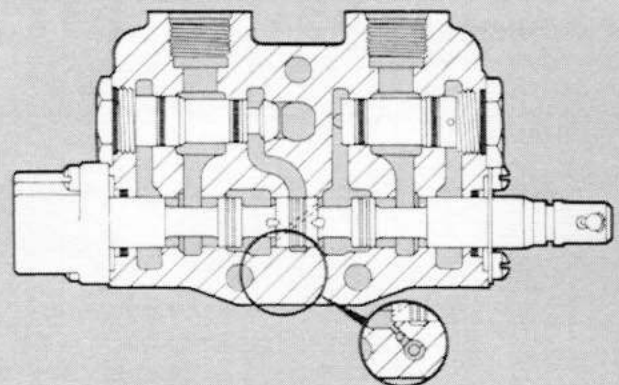

MODEL V20C WORK SECTION
WITH V20LS MODIFICATION
(8364 HOUSING)

SPOOL VARIATIONS

3-Way, 3-Position Spool

Code Symbol 3

Provides control of single acting cylinders or start and stop of non-reversible hydraulic motors where free-wheeling of motor is not required. The cylinder port is blocked in neutral position.

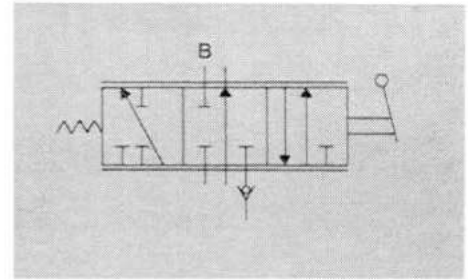

4-Way, 3-Position Spool

Code Symbol 4

Provides control of double-acting cylinders or reversible hydraulic motors where free-wheeling is not required. Cylinder ports are blocked in neutral position.

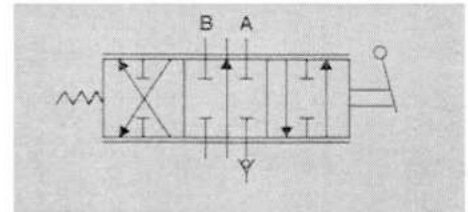

3-Way, 3-Position Free Flow Spool

Code Symbol F3

Provides control of single acting cylinders or start and stop of non-reversible hydraulic motors.

Allows a cylinder to drift or a motor to coast when the valve spool is in the neutral position.

The work port is open to tank port when the spool is in neutral.

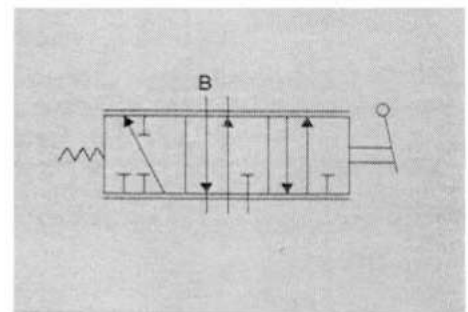

4-Way, 3-Position Free Flow Spool

Code Symbol F4

Provides for control of double-acting cylinders or reversible hydraulic motors.

Free flow spool allows a cylinder to drift or a motor to coast when the valve spool is in the neutral position. Work ports are open to the tank port when the spool is in neutral.

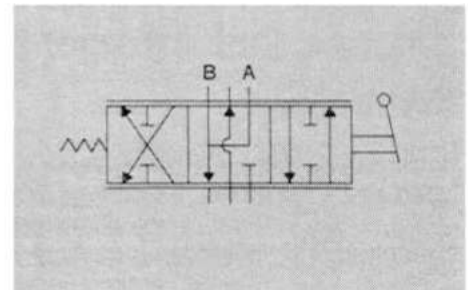

4-Way, 4-Position Float Spool

Code Symbol K4

This spool is the same as the 4-way, 3-position spool, with the addition of a fourth "Float" position.

This spool is spring-centered to neutral from the "A" or "B" work port power position.

Float section may be installed anywhere in the valve stack assembly.

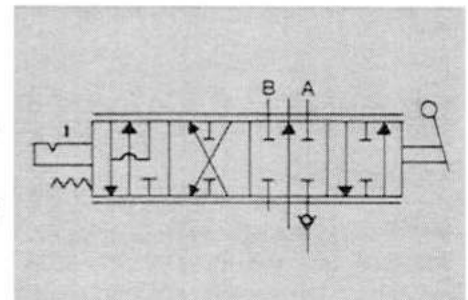

SYMBOLS SHOWN ARE
OPEN CENTER VALVES

SPOOL ACTION OPTIONS

Spring Return to Neutral

(Furnished as standard, unless otherwise specified)

Spool action has three positions with spring return to neutral from "A" and "B" power positions.

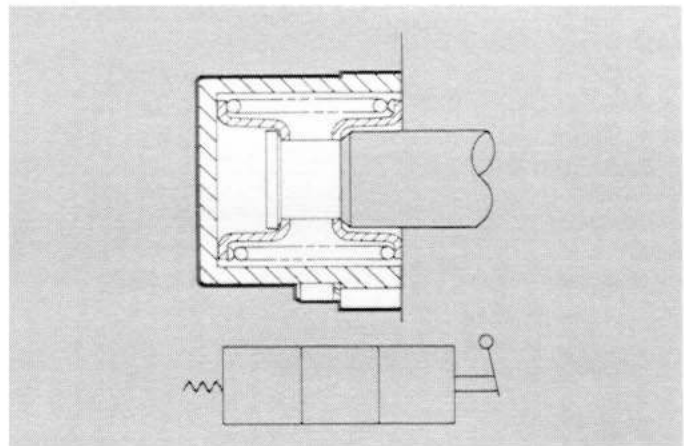

Spring Extended Spool

Code Symbol A

This feature eliminates spring-return to neutral, and spring loads the spool to the "OUT" position only (port "B" power position). Usually used for "Cam-Operation" of spool. Customer must supply cam-follower mechanism. When this option is ordered, a handle assembly is not furnished.

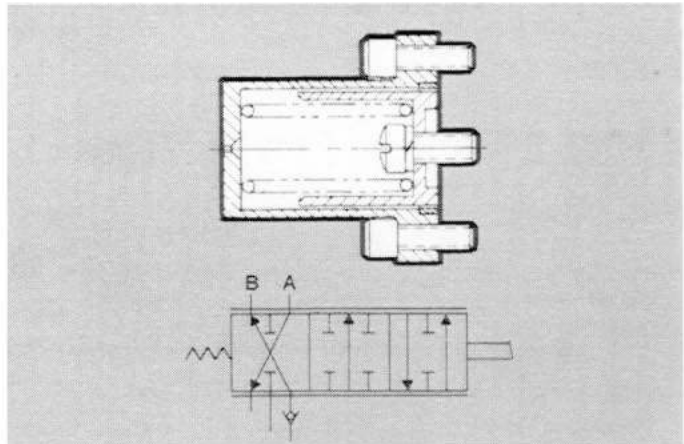

Rotary Spool Actuator

Code Symbol W

With this option, the movement of the spool is controlled by a rotary movement of the handle. Allows for 90° rotation of the spool each direction from center, making 180° total handle rotation with detent position in neutral. There is no spring-centering, therefore the spool will stay in any position placed. Handle assembly option not available with rotary actuator. (Customer must furnish his own handle mechanism.)

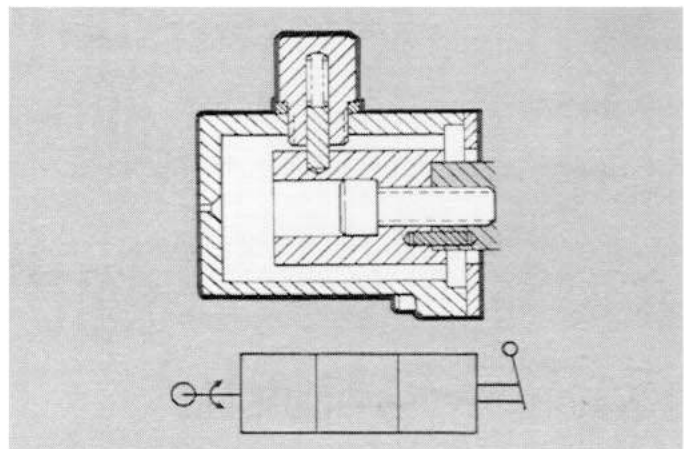

3-Position Detent

Code Symbol D

With this option the valve spool will remain in any of the three detented positions in which it is manually placed. No spring return to neutral.

Detent stop, 1889-001, is available to limit spool travel to two positions—neutral and spool "IN" or neutral and spool "OUT."

NOTE: The detent option is designed to provide operator "FEEL." It is NOT intended for use as a positive spool locking device against excessive external forces or machine vibration.

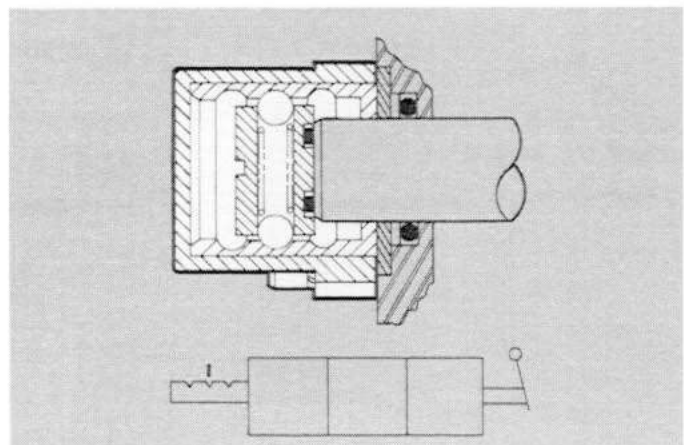

SPOOL ACTION OPTIONS (Cont.)

4-Position Float Assembly

Code Symbol K4

This option is spring-centered to neutral from the "A" or "B" work port power position. The fourth position is the detented "Float" position, which allows a cylinder to "Float" or a motor to "Free Wheel."

NOTE: Float spool positioners for Series type sections are different from those used in Parallel and Tandem sections.

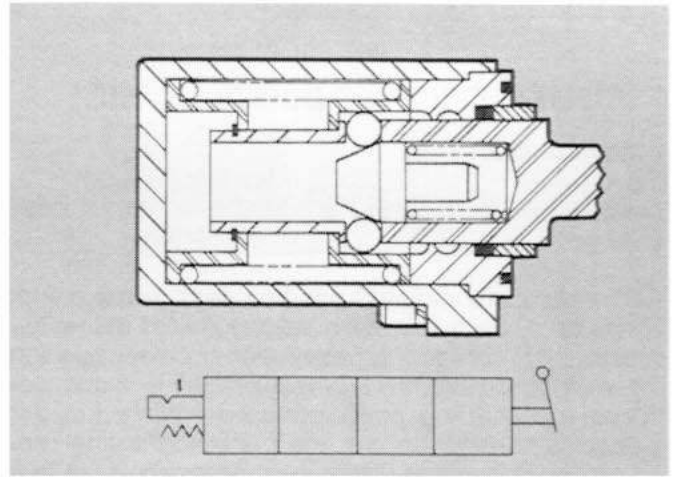

Manual Actuator

Code Symbol M

The manual spool permits full spool travel without spring centering or detent assemblies.

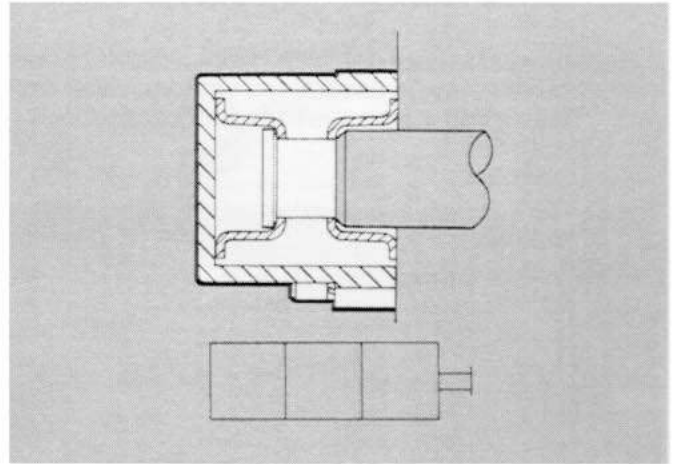

Optional Spool Detent Positions

1-POSITION SPOOL "IN" DETENT WITH SPRING RETURN to NEUTRAL

Code Symbol R

Work port "B" remains open to tank in detent position. Allows a single-acting cylinder to "Float."

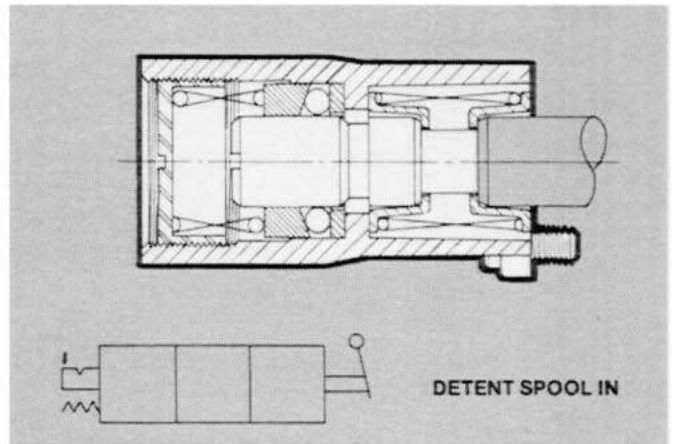

1-POSITION SPOOL "OUT" DETENT WITH SPRING RETURN to NEUTRAL

Code Symbol R0

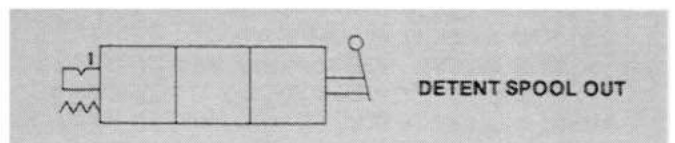

2-POSITION SPOOL "IN" and "OUT" DETENT WITH SPRING RETURN to NEUTRAL

Code Symbol R10

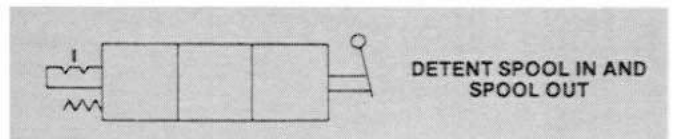

SPOOL ACTION OPTIONS (Cont.)

Internal Hydraulic Detent Release

Code Symbol KO

Automatically returns the spool to a neutral position as soon as the work cycle is completed.

The standard 4-way 3-position section has a 2-position detent with the spool spring loaded to the neutral position. The spool is held in either power position by the detent assembly. When pressure in the power circuit reaches a predetermined setting, the detent assembly releases and the centering spring returns the spool to neutral. Pressure detent release is field adjustable. Release pressure must be a minimum of 200 PSI [13,80 bar] below main relief setting.

As many valve sections with hydraulic detent release as required may be assembled into one valve assembly. This option is also available for float sections.

SPECIFICATIONS

Operating Range	500-3500 PSI [35-242 bar]
Normal Setting Tolerance	± 100 PSI [± 7 bar]
Handles	"A" or "B" Port End

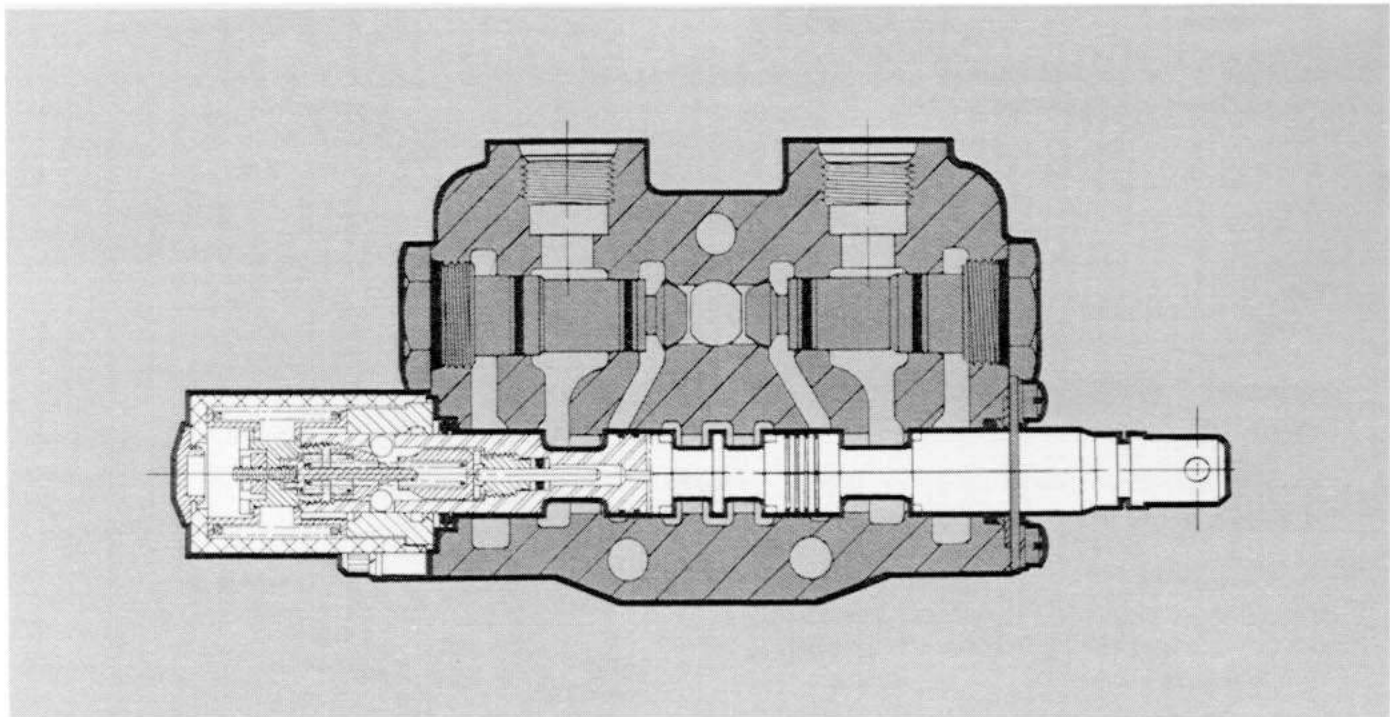
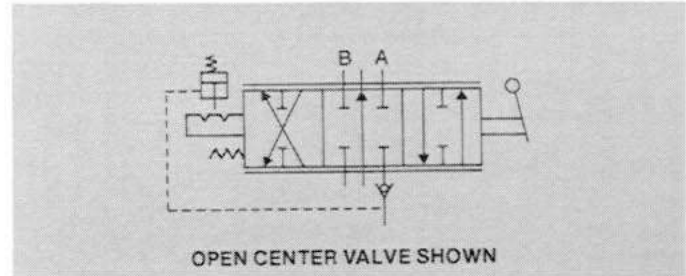

PRESSURE RELEASE FROM "A" POWER POSITION

Detent release pressure is sensed through the power core of the valve when the spool is in the "A" power position. In a valve assembly containing two or more KO sections, the section having the lowest detent pressure release setting will release its spool first when the spool is in the "A" power position. Each spool will release to neutral from the "A" power position as the pressure increases. The detent having the highest pressure setting will be the last to release to neutral.

PRESSURE RELEASE FROM "B" POWER POSITION

Detent release pressure is sensed only through the open center core of the valve when the spool is in the "B" power position. When an upstream spool is shifted to either power position, the open center core is blocked off preventing any downstream KO sections from sensing pressure in the open center core. Therefore, a downstream KO section will not release to neutral when an upstream spool is shifted to the "A" or "B" power position. A KO spool will only release to neutral from the "B" power position when all upstream sections are in the neutral or float position.

SPOOL ACTION OPTIONS (Cont.)

Electro-Magnetic Spool Release

Code Symbol E

This option incorporates two electro-magnets in the bonnet assembly. The magnets may be energized continuously with a 12 volt DC power supply. When the operator manually shifts the spool to either power position, the spool will be held in position by magnetic force. A return spring will center the spool to neutral when the magnet is de-energized, or the spool may be returned to neutral manually.

The male connector on the bonnet contains three pins marked A, B, and C. Both magnets are connected to a common ground (pin C), pin A is connected to the magnet which will hold the spool in the "A" power position (spool "IN"), and pin B is connected to the magnet which will hold the spool in the "B" power position (spool "OUT").

If a one position electric detent is required, only one magnet will be connected to the male connector. Pins A and C will be wired for spool "IN" detent, or pins B and C will be wired for spool "OUT" detent.

The electro-magnetic spool release assembly may be used with an external limit switch (furnished by the customer) to limit the stroke of a cylinder. This results in a more efficient operation, quicker cycle times, and saves time by automatically repositioning the cylinder while the operator is performing other operations. Another advantage is hydraulic system pressure does not build up to main relief valve pressure, which eliminates pressure surges and reduces heat build-up.

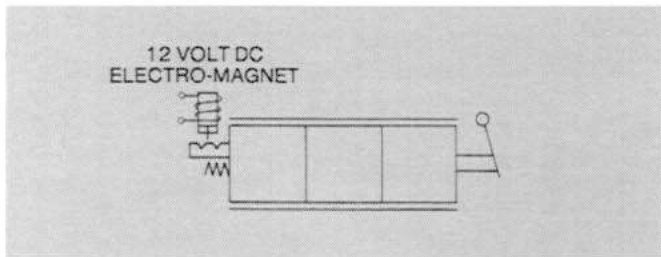

SPECIFICATIONS

Spools	Standard 3- or 4-way (not 4-way float)
Supply Voltage	12 volt DC
Male Bonnet Connector	MS 3102A-10SL-3P
Female Connector	MS 3106A-10SL-3S (Furnished by customer)

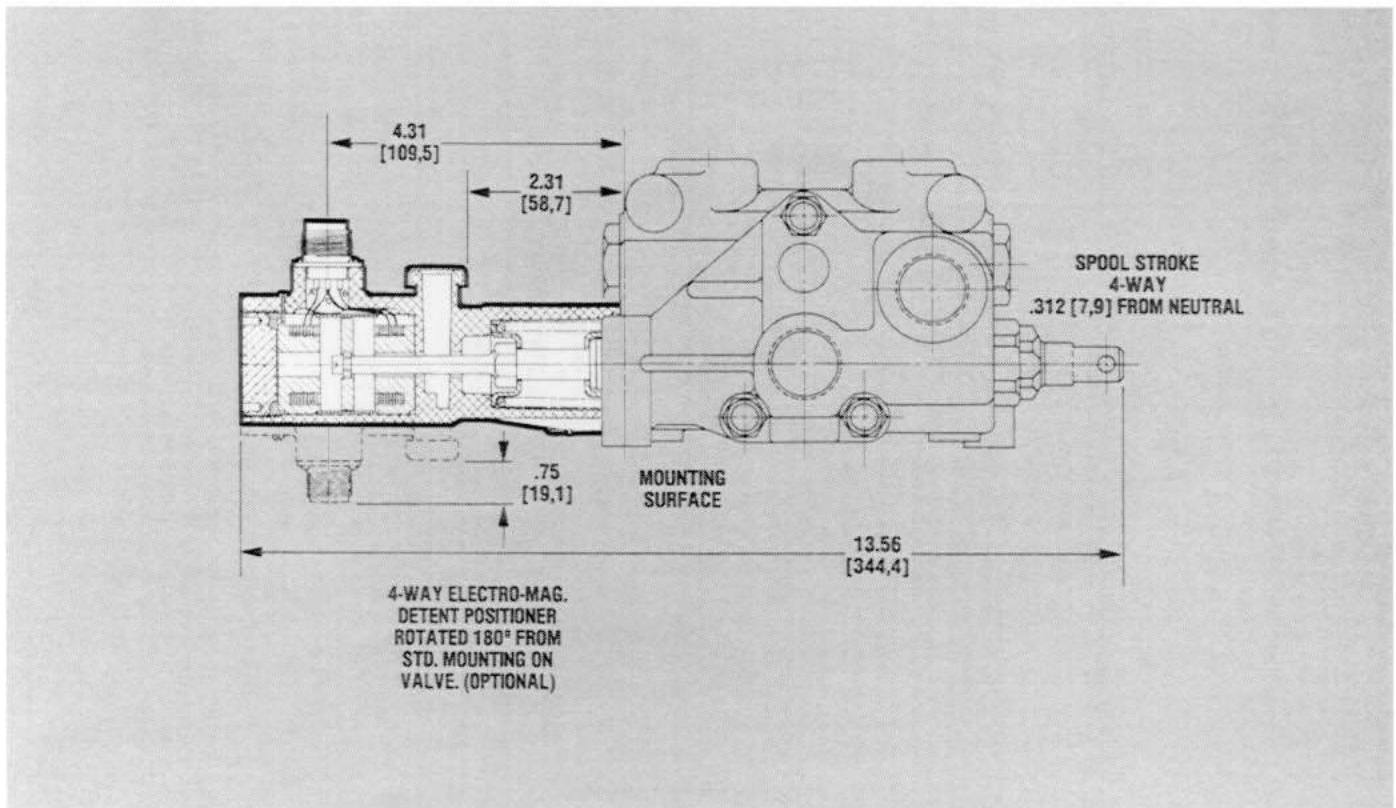

Hydraulic Remote Spool Actuator

Code Symbol HR, HRO and HRH

Hydraulic Remote Spool Actuators, Option Code HR, provide for remote operation of the Model V20 Directional Control Valve with two or three-position spools.

An external adjustment screw override, Option Code HRO, is available as an option. The screw provides for emergency manual operation in case of pilot pressure failure or permits lowering a load with the pump shut down.

A handle override feature is also available. Option Code HRH. This option allows full manual control at the valve with remote hydraulic control at a remote location. This option is ideal for applications where two control stations are required.

A customer-supplied, remotely located hydraulic controller will provide infinite spool positioning for metering flow to the work ports of the V20 Valve. The only limitation for metering capability is the pressure regulating performance of the hydraulic controller or the Valve.

Although valve work sections with Actuator control are normally assembled at the factory, field assembly on existing valve work sections is possible. Manually-operated valve work sections may be combined with Actuator-operated valve work sections in any arrangement.

For more information, refer to Gresen Catalog No. PC-1103.

SPECIFICATIONS

DIRECTIONAL CONTROL VALVE

Capacity (nominal) 20 GPM [75 litres/min]
Maximum Operating Pressure 3500 PSI [242 bar]
Maximum Exhaust Core Pressure 500 PSI [34 bar]

SPOOL ACTUATOR

For two, three, or four-position spool functions only
(Four-position for float operation)

Max. Pressure Rating 500 PSI [34 bar]

Pilot Pressure to Initiate Spool

Movement 60 PSI [4 bar]

Pilot Pressure to Compensate for

Spring Tension at Full Stroke 300 PSI [20 bar]

Pilot Flow 2 to 4 GPM [7.5 to 15 litres/min]

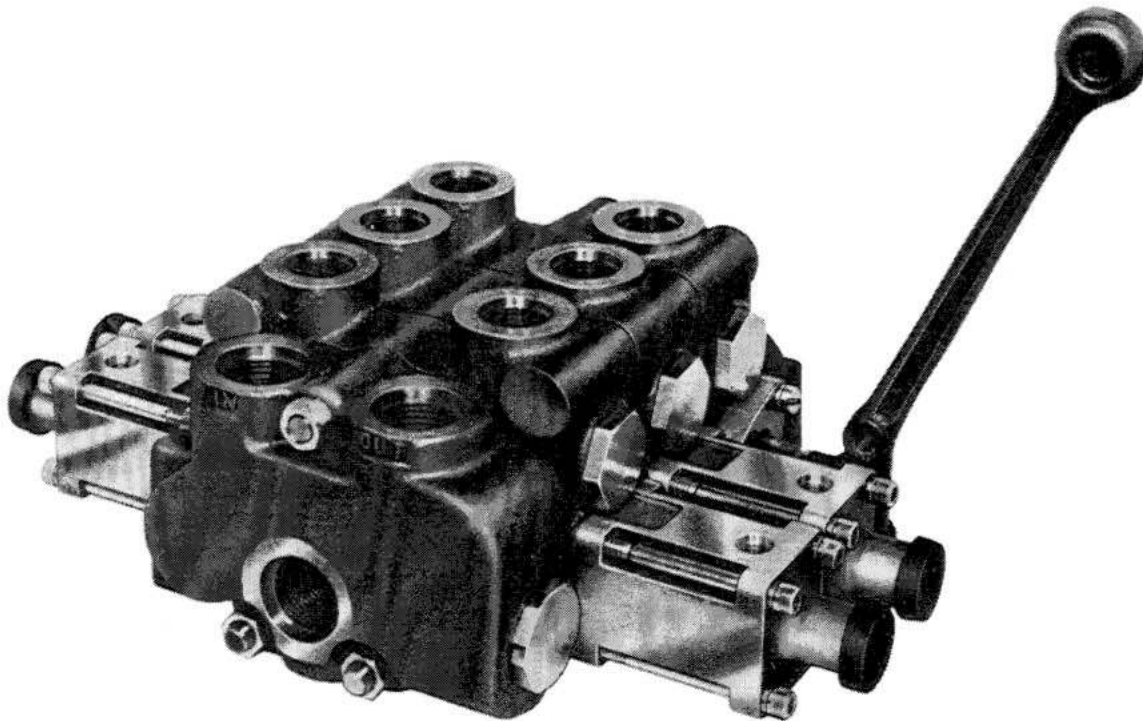

Option "HRO" Shown

Solenoid-Controlled Directional Control Valve

Gresen's on-off solenoid-controlled, pilot operated actuators are designed to provide remote operation of Model V20 Hydraulic Directional Control Valves.

Most Gresen Model V20 Sectional Body Directional Control Valves having a 3-position spool will accept a solenoid-controlled actuator. (Exceptions are the float spool and the standard Free Flow spool. A modified Free Flow spool is available for solenoid operation.)

Each Valve section may be solenoid-controlled, manually-controlled or both.

The sectional-body feature offers maximum flexibility and ease of maintenance. Although valve work sections with solenoid control are normally assembled at the factory, field assembly is possible in order to add additional work sections to an existing assembly.

The outlet tank port may be located in the outlet cover or in the left inlet cover of the control valve assembly.

A power beyond option is **not** available in the outlet cover of V20 solenoid operated valve assemblies. The power beyond option is available in the utility section. If a power beyond option is used in the utility section, the pressure build-up valve must be located in the downstream valve assembly.

For more information regarding electrical system requirements, optional accessories, and dimensions, refer to Gresen Catalog No. PC-1104.

SPECIFICATIONS

Pressure Rating 3500 PSI [242 bar] max.
(Directional Control Valve)

Capacity (Nominal) 20 GPM [75,5 litres/min]

Differential Pilot

Pressure to Actuator 200-300 PSI [14-21 bar]
(A minimum of 200 PSI [13,8 bar]
is required to actuate the valve spool)

Maximum Allowable

System Back Pressure 300 PSI [21 bar]

Pilot Flow to Actuator 2-4 GPM [7,6-15 litres/min]

Operating Oil Temp 180°F [82°C]
(Maximum)

Filtration Req. (Min.) 33 micrometre

Solenoid Power Req. 1.7-1.9 amps, 12 VDC
0.6-0.7 amps, 24 VDC

Weight:

Directional Control Valve Work

Section with Solenoid-Controlled

Actuator Approx. 13 lbs. [5,9 kg]

Utility Section Approx. 9 lbs. [4.1 kg]

Note: Double-throw switches are required when using internal pilot and must be provided by the customer.

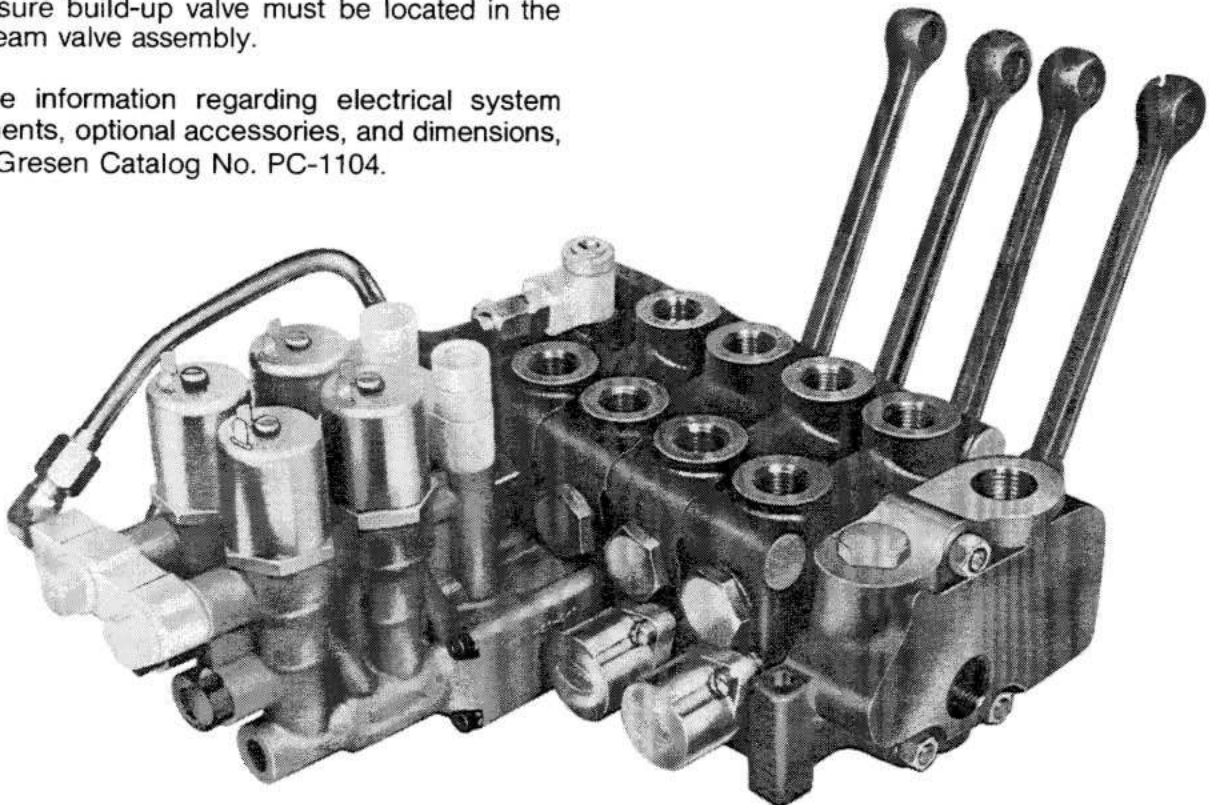

HANDLE-END OPTIONS

The clevis end of the spool may be located at either the "A" port or "B" port end of the work section . . . except for the Model V20LS float option (K4) which must be on the "A" port end only. Unless otherwise specified, the handle end will be located at the "A" port end for all sections.

The following handle options are available:

- Complete Vertical Handle and Bracket Assembly (CVHA)
- Complete Horizontal Handle and Bracket Assembly (CHHA)
- Less Handle Only (LHO)
- Less Complete Handle Assembly (LCHA)
- Handle Bracket Only (HBO)

Complete Handle and Bracket Assembly (CVHA or CHHA)

When handles are required, choose between a vertical and horizontal ductile iron handle. Two brackets—die cast or cast iron—are also available as required for the application.

Handles and handle brackets should be specified by using the following part numbers:

- 1802-001 Vertical Handle (Black)
- 1802-003 Vertical Handle (Plain)
- 3249-001 Horizontal Handle (Black)
- 3249-003 Horizontal Handle (Plain)
- 1801-001 Die Cast Handle Bracket
- 7355-001 Cast Iron Handle Bracket

If a complete handle and bracket assembly is ordered without specifying part numbers for vertical or hori-

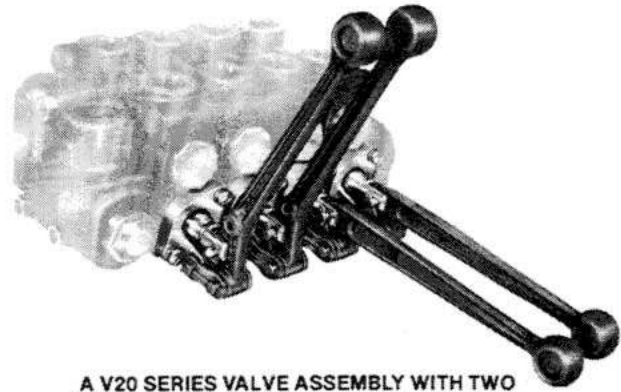

A V20 SERIES VALVE ASSEMBLY WITH TWO HORIZONTAL AND TWO VERTICAL HANDLES.

zontal handles, a vertical handle (1802-001) and die cast bracket (1801-001) will be furnished. The bracket may be rotated 180° to reverse handle movement or allow handle to extend below the valve.

Less Handle Only (LHO)

When the application requires a complete bracket and linkage assembly, without a handle, then this designation—LHO—should be specified. An 1801-001 die-cast bracket will be furnished as standard. A 7355-001 cast iron bracket is optional.

Handle Bracket Only (HBO)

Handle and link assembly is omitted. Only a 1801-001 die-cast bracket is installed. A 7355-001 cast iron bracket is optional.

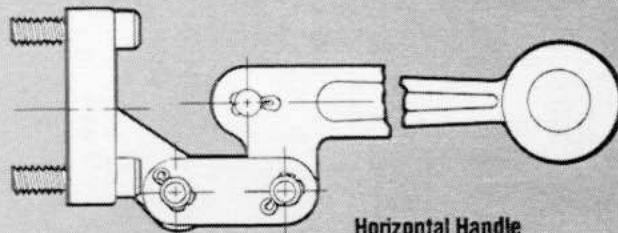

Horizontal Handle (3249-001) and Bracket Assembly

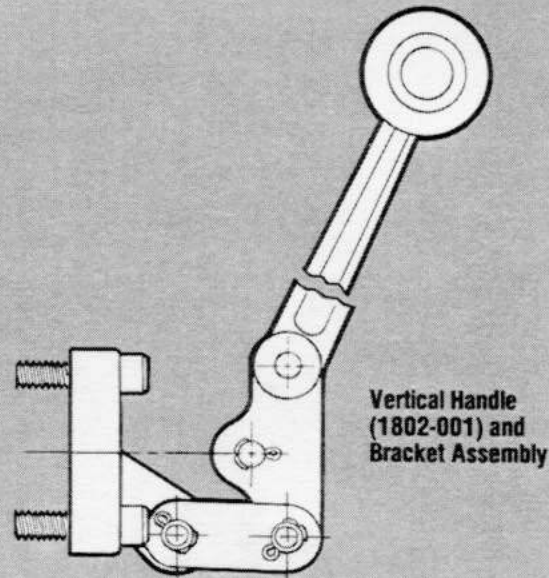

Vertical Handle (1802-001) and Bracket Assembly

HANDLE END OPTIONS (Cont.)

Less Complete Handle Assembly (LCHA)

When a valve work section is specified to be furnished LCHA, the complete handle and bracket assembly will be omitted. When this is done, a spool seal retainer assembly is installed to hold the spool seal assembly in place.

STANDARD SPOOL SEAL RETAINER ASSEMBLY (SPECIFY)

When the complete handle and bracket assembly is omitted from a work section and allowable back pressure is limited to 200 PSI [13,8 bar] a standard spool seal retainer will be installed.

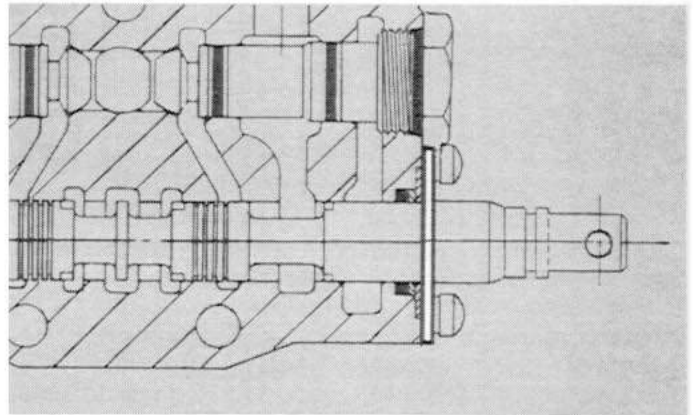

HEAVY DUTY SPOOL SEAL RETAINER ASSEMBLY (SPECIFY)

A heavy duty spool seal retainer must be included in a work section if:

1. Back pressure at the spool seal could exceed 200 PSI [13,8 bar], but not over 1000 PSI [69,00 bar].
2. A secondary spool wiper is desired to reduce contamination at the spool seal. . .

NOTE: Maximum continuous operating exhaust core pressure should not exceed 500 PSI [34 bar].

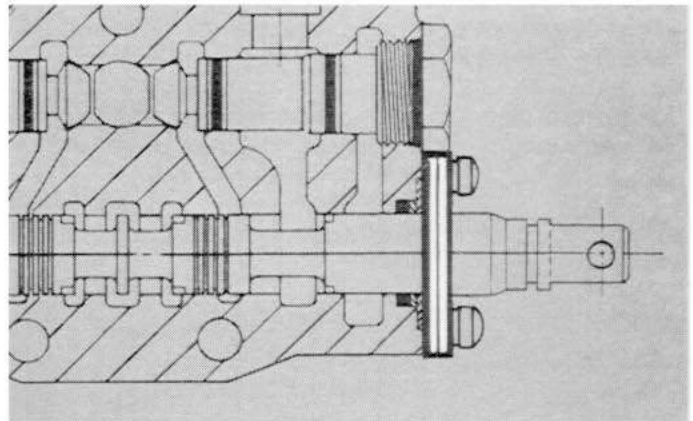

SPOOL PROTECTIVE BOOT ASSEMBLY

A spool protective boot assembly may be used with both the standard retainer assembly and the heavy duty retainer assembly. The boot completely covers the spool seal assembly protecting the area from contamination thereby providing longer seal life. The boot assembly cannot be used if a handle bracket is installed.

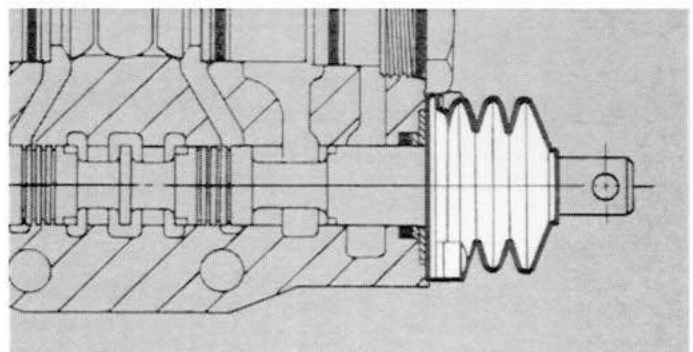

SECONDARY SPOOL WIPER SEAL (NO. 1800-001)

An optional wiper seal may be installed in the spool seal area on the handle end to minimize external contamination. The wiper is secured by either the heavy duty retainer or handle bracket. May not be used with standard low pressure seal retainer assembly.

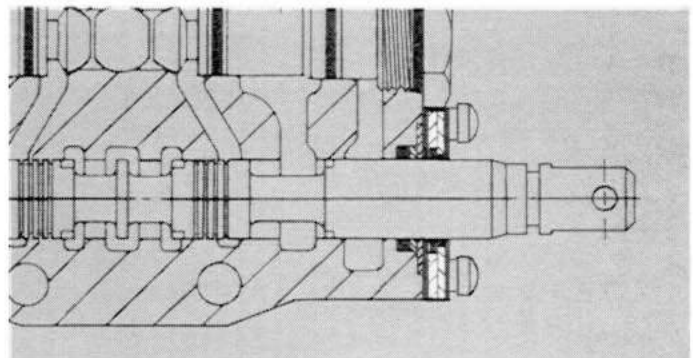

SPECIFYING GRESEN SECTIONAL BODY DIRECTIONAL CONTROL VALVES

Sectional Body Valves are custom assembled to meet specific application requirements.

When ordering a work section, valve component or a complete valve assembly, submit the information required in the Table of Options for Complete Valve Assemblies, page 54. Submit all of the information that applies to your application. Add any option information not specifically referred to in this catalog.

To properly specify the individual work sections, follow this procedure:

Using the diagram below, work ports should be on top with the "A" port nearest you. Inlet cover will be to your left and the outlet cover to your right.

The accompanying sketch of a typical control valve

assembly has the handle assemblies in the standard location at the "A" port end of the valve.

Valve assembly specification forms are available to help simplify the ordering of various sections or complete valve assemblies. When ordering V20 Valves, use Form No. 9005. Specification forms have been included at the back of this Catalog. If additional forms are needed, contact any Gresen Distributor, Representative or the Sales Department, Minneapolis.

On receipt of the information, an order design number will be assigned to your valve assembly. Then, on future orders, the order design number or your part number need only be specified to identify the correct valve section, or assembly.

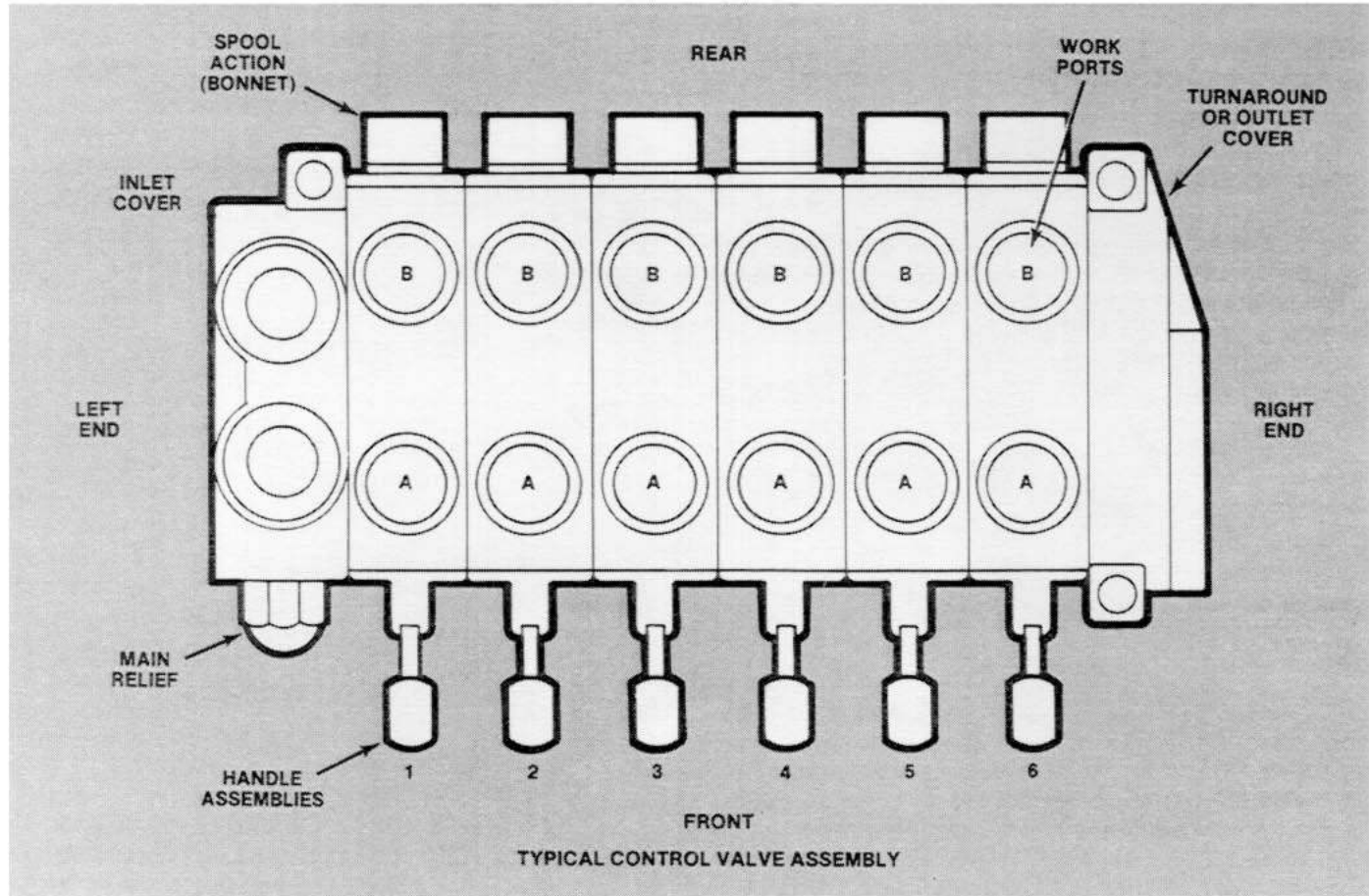

OPEN CENTER VALVE ASSEMBLIES

Models V20P, V20T, V20PT and V20S

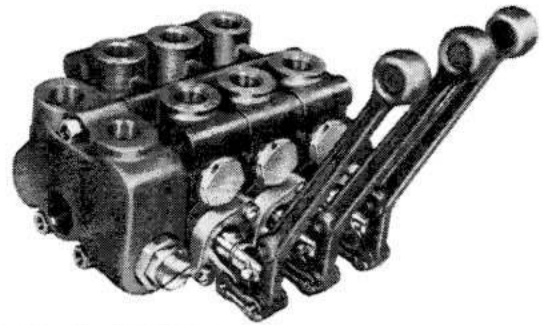

Models V20P, V20T, and V20S Valve Assemblies utilize the same inlet and outlet covers, and most of the same basic options.

Model V20P, V20T, and V20S sections may be combined into one valve assembly. See page 38 for V20S stacking sequence restrictions.

FEATURES

- Minimal spool actuating effort—Maximum, 50 pounds [22,6 kg] at the spool
- Improved, extra-fine metering
- Minimum pressure drops through open center and through work ports
- Float section may be installed at any point within the Valve assembly

INLET COVERS

All Model V20 valve inlet covers are machined for the Model WH main relief. If the relief is not required, a no relief (NR) plug will be installed. The following inlet covers are available:

Inlet Cover, No. 8398

No. 8398 inlet cover is available with top, end and bottom inlet ports. It is also available with top and end outlet ports. Top in and top out are the standard port locations for this cover.

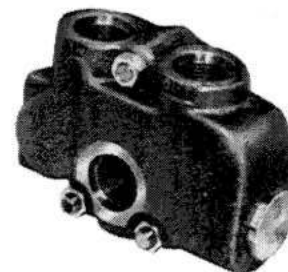

NO. 8398 INLET COVER

SPECIFICATIONS

Pressure Rating:

Continuous Operating 3500 PSI [242 bar] max.

Maximum Exhaust Core Pressure:

With Handle Bracket or Heavy Duty Spool Seal Retainer Installed

Continuous Operating 500 PSI [34,5 bar]

Intermittent Peak 1000 PSI [69,0 bar]

With Standard Spool Seal Retainer

Installed 200 PSI [13,8 bar]

Capacity Refer to Pressure Drop Charts.

Flow rate is determined by the maximum pressure drop acceptable for the application.

Filtration Required (Min.) 33 micrometre

Weight:

Inlet Cover Approx. 6 lbs. [2,7 kg]

Outlet Cover Approx. 3 1/2 lbs. [1,6 kg]

Work Section, Each Approx. 9 lbs. [4,1 kg]

PORTING OPTIONS AVAILABLE

LOCATION	SAE STRAIGHT THREAD PORTS		NPT PIPE PORTS**	BSP PIPE PORTS	GAGE PORTS
	STANDARD	OPTIONAL	OPTIONAL	OPTIONAL	OPTIONAL
No. 8398 LEFT INLET COVER End, Top or Bottom* Inlet Ports. End or Top Outlet Ports.	SAE 12 (1-1/16" - 12 UN)	SAE 10 (7/8" - 14 UNF)	1/2" - 14 3/4" - 14	3/4" BSP	SAE 4 (7/16" - 14 UNF)

*Bottom inlet available only with SAE 10 or 3/4" NPT ports.

**NPT pipe ports are not recommended for pressure ports above 2000 PSI [138 bar].

NOTE: All ports in a casting must be the same type. SAE, BSP and NPT cannot be intermixed. Top inlet and top outlet ports are cored. If not specified, they will be plugged.

Inlet Cover, No. 7736 With Flow Control

A No. 7736 Inlet Cover contains an adjustable flow control assembly which directs the controlled portion of the inlet flow to the work ports and any excess flow into the exhaust core. The adjusted flow is pressure compensated and is the maximum amount of flow available to any work section in the valve assembly.

This inlet cover is machined for the Model WH relief. A no relief (NR) plug may be installed if the main relief valve is not required.

PORTING OPTIONS AVAILABLE

SAE and NPT ports cannot be intermixed in the same casting.

LOCATION	NPT PIPE PORTS		SAE STRAIGHT THREAD PORTS	
	STANDARD	OPTIONAL	STANDARD	OPTIONAL
END INLET	3/4"-14		SAE 12	SAE 10
TOP INLET	3/4"-14		SAE 12	SAE 10
END OUTLET	3/4"-14		SAE 12	

FLOW CONTROL RANGE TO 25 GPM [95 litres/min].

A control knob is furnished as standard. If it is to be omitted, please specify.

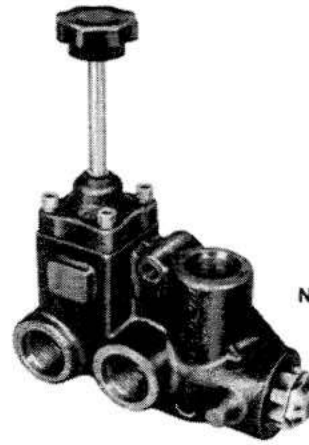

NO. 7736 INLET COVER

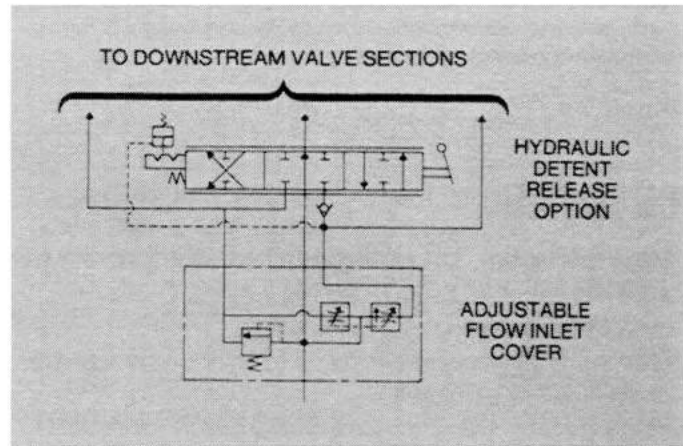

Excess Flow Option

This option utilizes the excess flow from the flow control by using the end outlet port as the excess flow port. An outlet port is not available in this cover when this option is specified. A typical application for this option is to direct the excess flow to a combined flow mid-inlet section installed downstream. When the upstream spools are in neutral, all flow is avail-

able downstream. When an upstream spool is activated, only excess flow oil is available to the downstream spools. This option also allows the flow from one pump to be split for two separate functions.

To order this option, specify "Plug B end exhaust core".

Main System Relief Valve

The main system relief valve is installed in the inlet cover. A detailed description of the main relief valve, its options and performance will be found on pages 10 and 11.

Relief setting at "crack pressure" or at "full flow" must be specified.

A main relief valve is available in the following configurations:

	ORDER CODE
Standard (adjustable with shims)	WH
Tamperproof (adjustable with shims)	WHNJ
Adjustable with screwdriver	WHA
Pilot operated relief	RP51
No Relief Plug (no relief valve installed).	NR

OPTIONS:

- Stainless steel relief springs
- VITON seals to replace standard BUNA-N seals

OUTLET COVERS

A variety of options and combinations of port sizes are offered. These options enable the user to customize valve assemblies while minimizing external plumbing. In addition, four application variations are available:

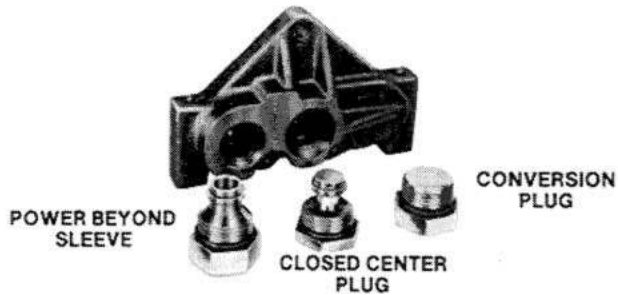

NO. 6770 OUTLET COVER WITH POWER BEYOND SLEEVE, CLOSED CENTER AND CONVERSION PLUG.

Outlet cover, No. 6770, is available for use with four application variations:

1. Open Center (standard)
2. Closed Center (conversion)
3. Power Beyond
4. Conversion Plug

Application variations are all accomplished by the machining and/or assembly of the outlet cover. Machining and assembly of the inlet cover and center sections do not affect these variations.

Outlet Port Option ...

If the outlet port is to be located in the outlet cover and closed center, power beyond or conversion plug options are specified, then the outlet port will be in the optional location.

Turnaround Cover Option ...

For plumbing convenience, the outlet port may be located in the inlet (left) cover. When it is, the turnaround (right) cover will direct the exhausting oil back to the inlet cover.

Application Variations ...

Application variations are all accomplished by the machining and/or assembly of the outlet cover. Machining and assembly of the inlet cover and center sections do not affect these variations.

OPEN CENTER

(Furnished as standard, unless otherwise specified)

Hydraulic oil is directed from the inlet port, thru the open center core to the outlet port of the Directional Control Valve when all spools are in the neutral position. Shifting the valve spool directs oil flow to the desired work port.

Maximum circuit pressure is limited by the main relief valve, which relieves into the exhaust core.

The standard Gresen valve is an open center control valve. The inlet port is open to the tank port, and both work ports are blocked when the control valve spool is in neutral position, thereby holding the cylinder or hydraulic motor in position.

The outlet port may be located in the right cover . . .

OR

Outlet port may be located in the left cover when a right turnaround cover is used.

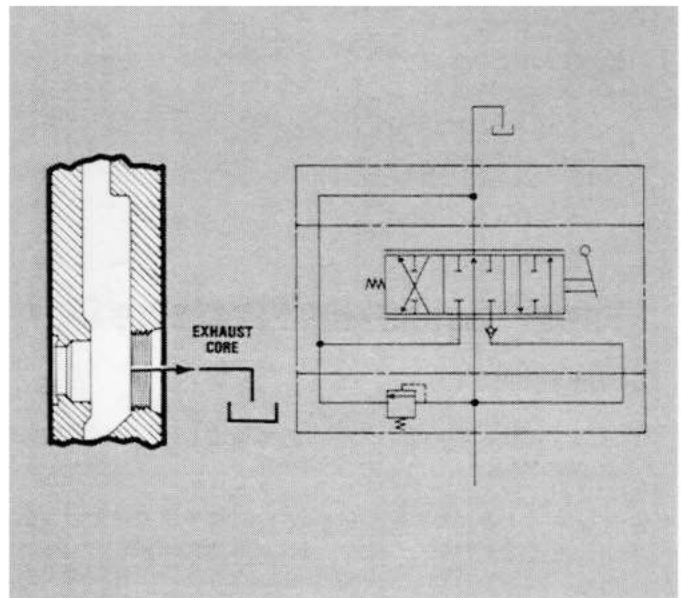

Closed Center

Code Symbol C

To convert an open center valve to a closed center valve.

By installing a special closed center plug in the outlet cover, hydraulic oil flow from the pump is blocked at the outlet port with valve spools in neutral position.

Pressure is normally maintained at the control valve inlet by use of a variable-displacement pump or an accumulator-type circuit with an unloading valve.

In a Gresen closed center control valve, the center passage is blocked and both work ports are also blocked when the control valve spool is in neutral position.

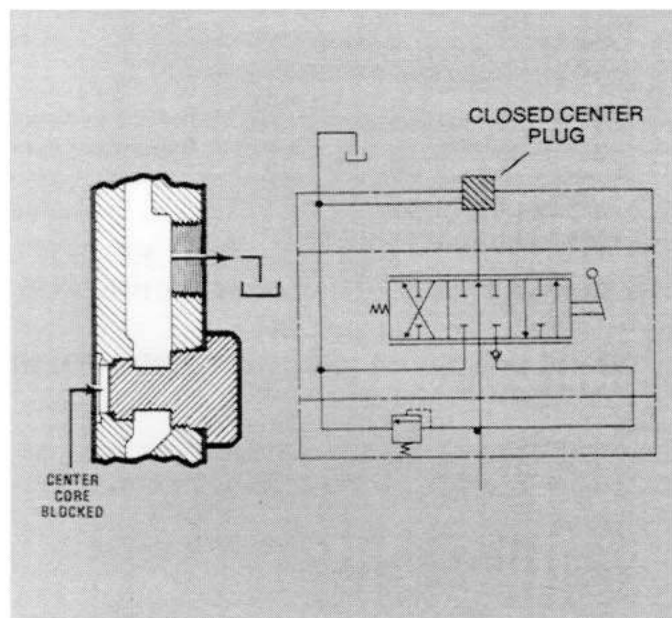

same, only one relief valve is required. It must be installed in the upstream valve.

Each valve in the circuit may have a different relief setting, but the highest setting must be upstream.

The outlet cover can be machined to accept a power beyond sleeve which allows the open center oil to be used by a downstream valve. When a power beyond sleeve is specified, an outlet port is still required. Outlet port can be located in the left inlet cover or in the right outlet cover. The following power beyond sleeve port sizes are available for No. 6770 right outlet cover:

THREAD	1/2" - 14 NPT (Female) SAE 8 (3/4" - 16 UN) (Female) SAE 10 (7/8" - 14 UN) (Female) SAE 16 (1" tube fitting) (Male)
--------	--

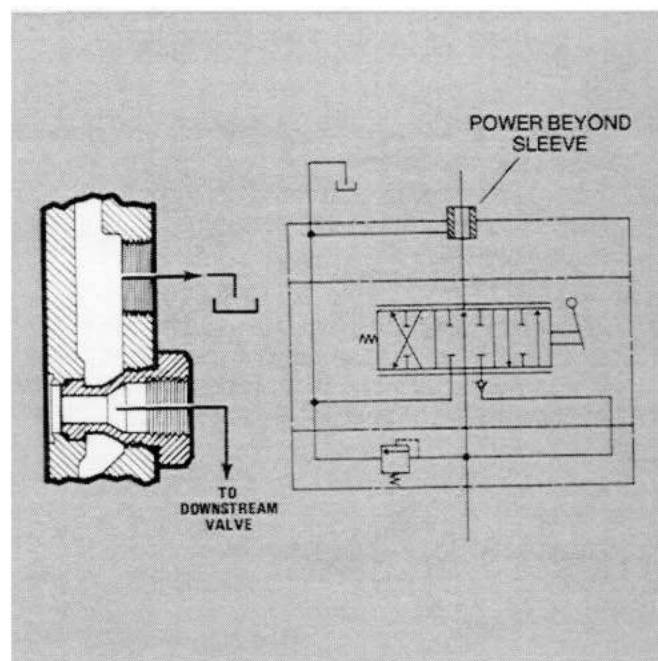

Power Beyond (High Pressure Carryover)

Code Symbol Y

This option allows the installation of another valve downstream from the first valve.

A power beyond sleeve is installed in the outlet cover of the upstream valve which separates the open center core from the exhaust core at the outlet port. This allows hydraulic oil under pressure to be carried thru the upstream valve, thus making it available for a downstream function. A separate tank line is required from each control valve in the circuit.

Hydraulic oil is available to the downstream valve only when all spools in the upstream valve are in the neutral position.

If pressure requirements for both valves are the

Conversion Plug Assembly

Code Symbol X

If additional hydraulic circuit options are to be added at a later date, or if the control valve is being ordered for stock, a conversion plug assembly should be considered. A conversion plug assembly gives a control valve great versatility and easily converts for different applications, reducing inventory requirements.

A control valve with a conversion plug remains an open center valve. The outlet cover, when machined for this option, will also accept power beyond sleeves and closed center plugs. When the need arises the proper plug or sleeve is inserted to convert the assembly into either a closed center or power beyond

valve. Service kits are available for these optional parts and must be ordered separately.

When a conversion plug is installed in the outlet cover the control valve remains an open center valve. When the outlet cover is machined for a conversion plug, it will also accept a power beyond sleeve or a closed center plug. If the need arises, the proper plug or sleeve can be inserted to convert the assembly to either a closed center or power beyond application.

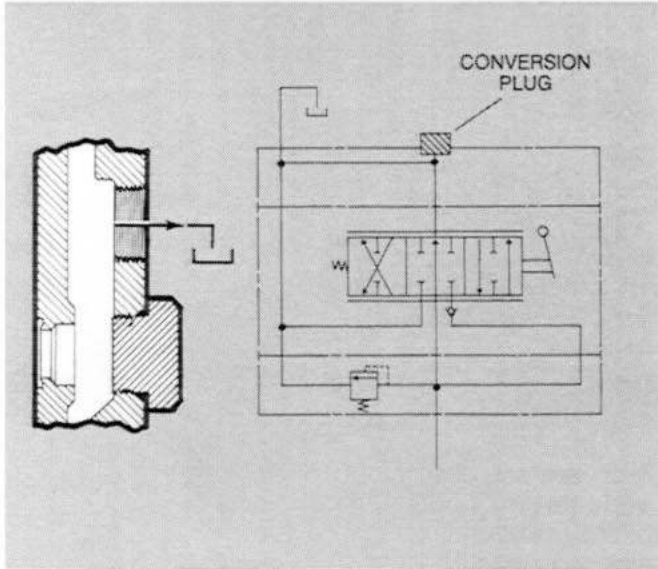

Outlet Port Option

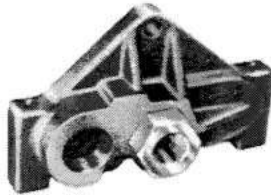

OUTLET COVER FOR MODEL V20P VALVE SHOWING OPTIONAL PORT LOCATION AND POWER BEYOND SLEEVE INSTALLED

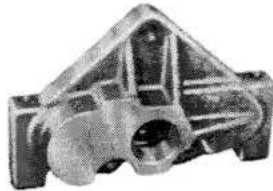

OUTLET COVER FOR MODEL V20P VALVE SHOWING STANDARD PORT LOCATION

If the outlet port is to be located in the outlet (right) cover and closed center, power beyond or conversion plug options are specified, then the outlet port will be in the optional location.

The following outlet port sizes are available for No. 6770 right outlet cover:

Outlet Ports	THREAD	
	NPT	SAE
	1/2" - 14	SAE 10 (7/8" - 14 UN)
	3/4" - 14	SAE 12 (1-1/16" - 12 UN)

Turnaround Cover Option

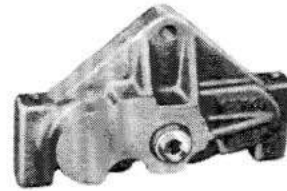

OUTLET COVER FOR MODEL V20P VALVE SHOWING TURNAROUND

For plumbing convenience, the outlet port may be located in the inlet (left) cover. When it is, the turnaround cover is provided to direct the flow of exhausting oil back to the inlet cover.

Optional Outlet Cover with Top Outlet and Power Beyond Ports No. 8644

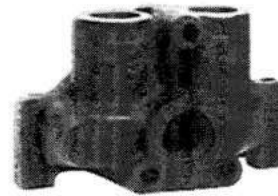

OPTIONAL OUTLET COVER FOR MODEL V20P VALVE SHOWING TOP OUTLET AND POWER BEYOND PORTS.

An optional outlet cover, No. 8644, is available. This option offers top porting options rather than end porting only. Port options are:

- Top, End or Bottom Outlet
- Top Power Beyond
- SAE12 or 3/4" NPT Ports

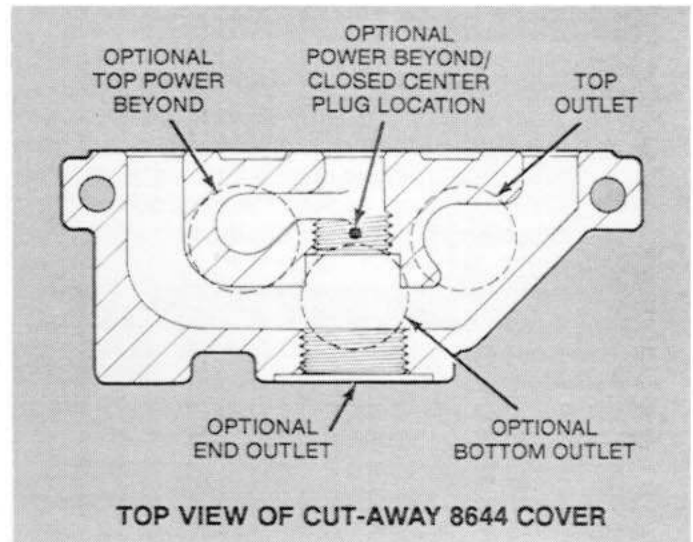

WORK PORT RELIEFS, CHECKS AND RESTRICTORS

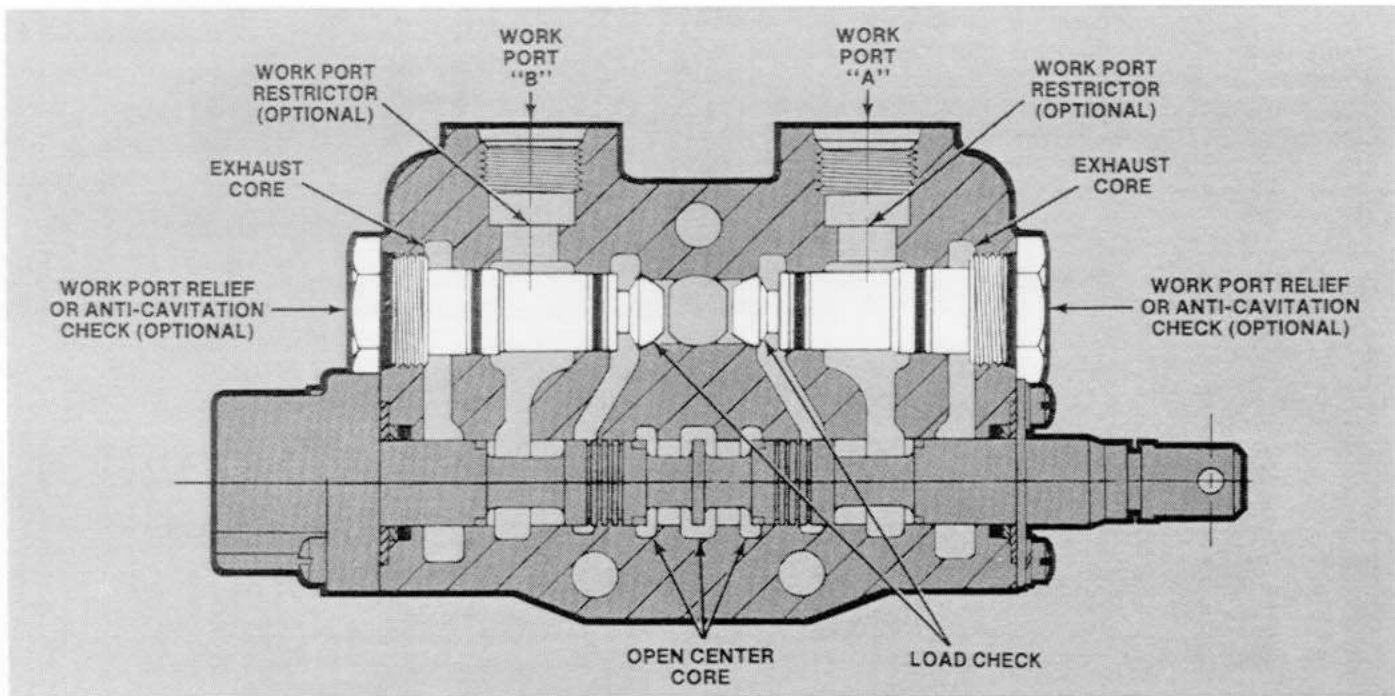

In addition to load checks which are standard in the V20 Valves, Gresen offers a wide range of options to control oil flow. From these options you may select the exact accessories to customize your valves to your specific application.

The following are available:

- Work Port Relief Valve
- Anti-Cavitation Check
- Combination Relief and Anti-Cavitation Check
- Pilot-Operated Check Valves
- Work Port Restrictors
(not available with NPT pipe ports).

Standard Load Check Assembly

A standard load check assembly is provided with every work section except when a free-flow motor spool is installed. Then load checks are not required. The load check blocks against pressurized return flow from a work port back to the inlet port until overcome by pressure build-up from the pump.

This feature will keep a load from dropping while the control valve spool is being shifted and until the inlet pressure is equal to or slightly greater than the pressure developed by the load. At this time the load check will open and movement of the load can then be controlled by the control valve spool.

NOTE: Load checks for Series type sections are different from those used in Parallel and Tandem sections.

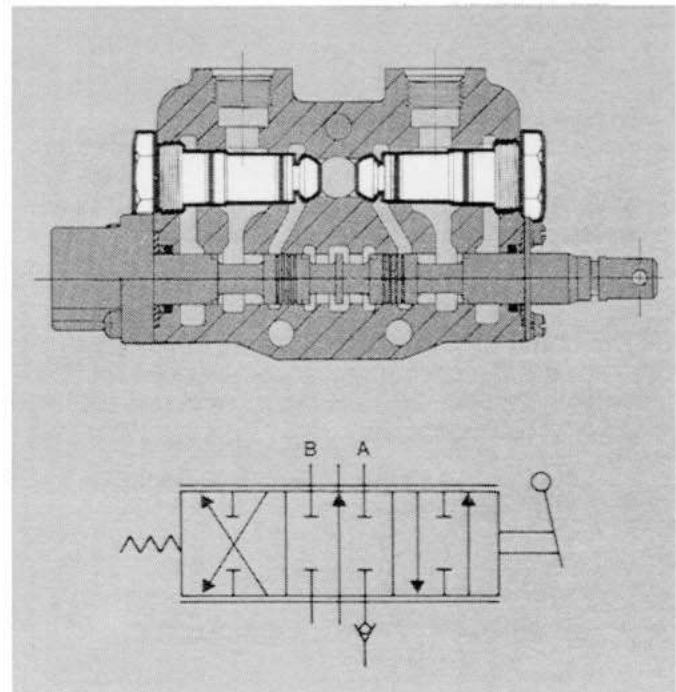

Work Port Relief Valves

MODELS RC and RCS (Series)

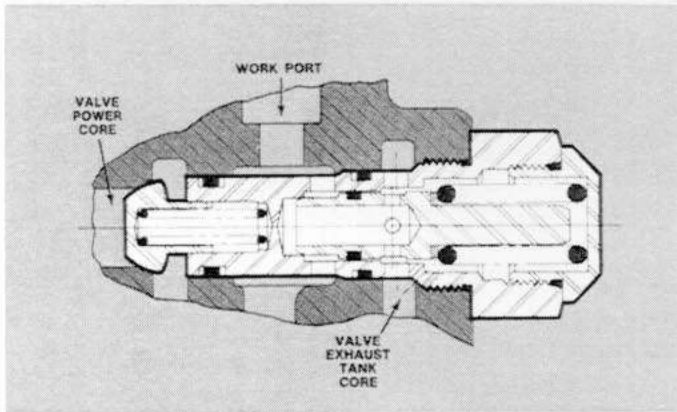

Models RC and RCS work port relief valves are differential poppet type.

Model RP20 recommended for pressures over 3000 PSI [207 bar].

NOTE: If the control valve is equipped with vertical handle, 1802-001, the adjustable relief valve, Model RCA which has an extended profile beyond valve body, will interfere with handle. It should NOT be installed on the valve-handle end.

These relief valves, installed in a work port, will limit the maximum pressure in that work port. They also prevent pressure build up in a work port when the valve spool is in neutral.

MODEL RP20

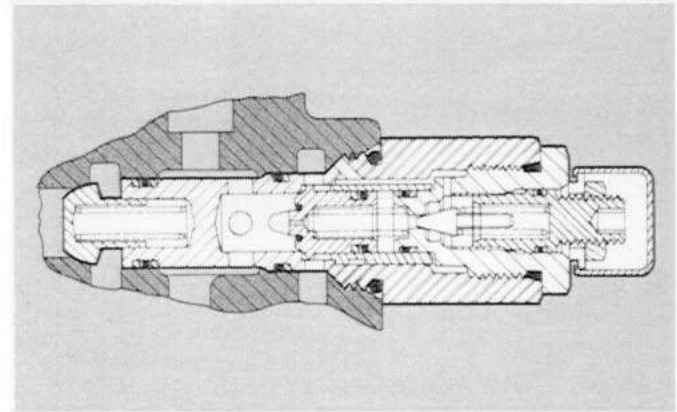

Model RP20 work port relief valves are pilot-operated type.

- Model RP20A — externally adjustable
- Model RP20N — tamperproof

2-STAGE RELIEF VALVE

A 2-stage relief option is available for Model RC work port relief valve cartridges. This option will provide a second (higher) pressure setting when a pilot pressure (750 PSI minimum) is applied to an SAE 6 pilot port in the cartridge. The "high" pressure setting (3000 PSI

maximum) is shim adjustable. The "low" pressure setting (500 PSI c/p minimum) is externally screw adjustable and must be specified as a "crack" pressure (1 GPM flow).

Anti-Cavitation Check

The anti-cavitation check is used in the work section and prevents cylinder or motor cavitation. It allows cavitating work ports to refill from the exhaust core, supplementing pump flow. Anti-cavitation check is non-adjustable but is designed to operate whenever the work port pressure is lower than the exhaust core pressure.

NOTE: Anti-cavitation checks for Series type sections are different from those used in Parallel and Tandem sections.

PERFORMANCE

- Will pass 5 GPM [18,93 liters/min] at 8 PSI [.55 bar] Pressure Differential
- Will pass 10 GPM [37,85 liters/min] at 19.5 PSI [1,35 bar] Pressure Differential
- Will pass 15 GPM [56,78 liters/min] at 39 PSI [2,69 bar] Pressure Differential

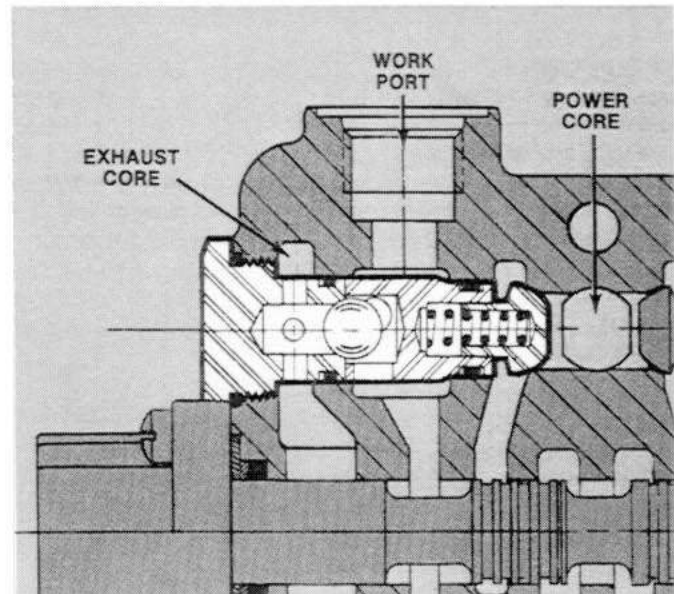

Pilot-Operated Check Valves

FOR MODEL V20-LO VALVE ONLY

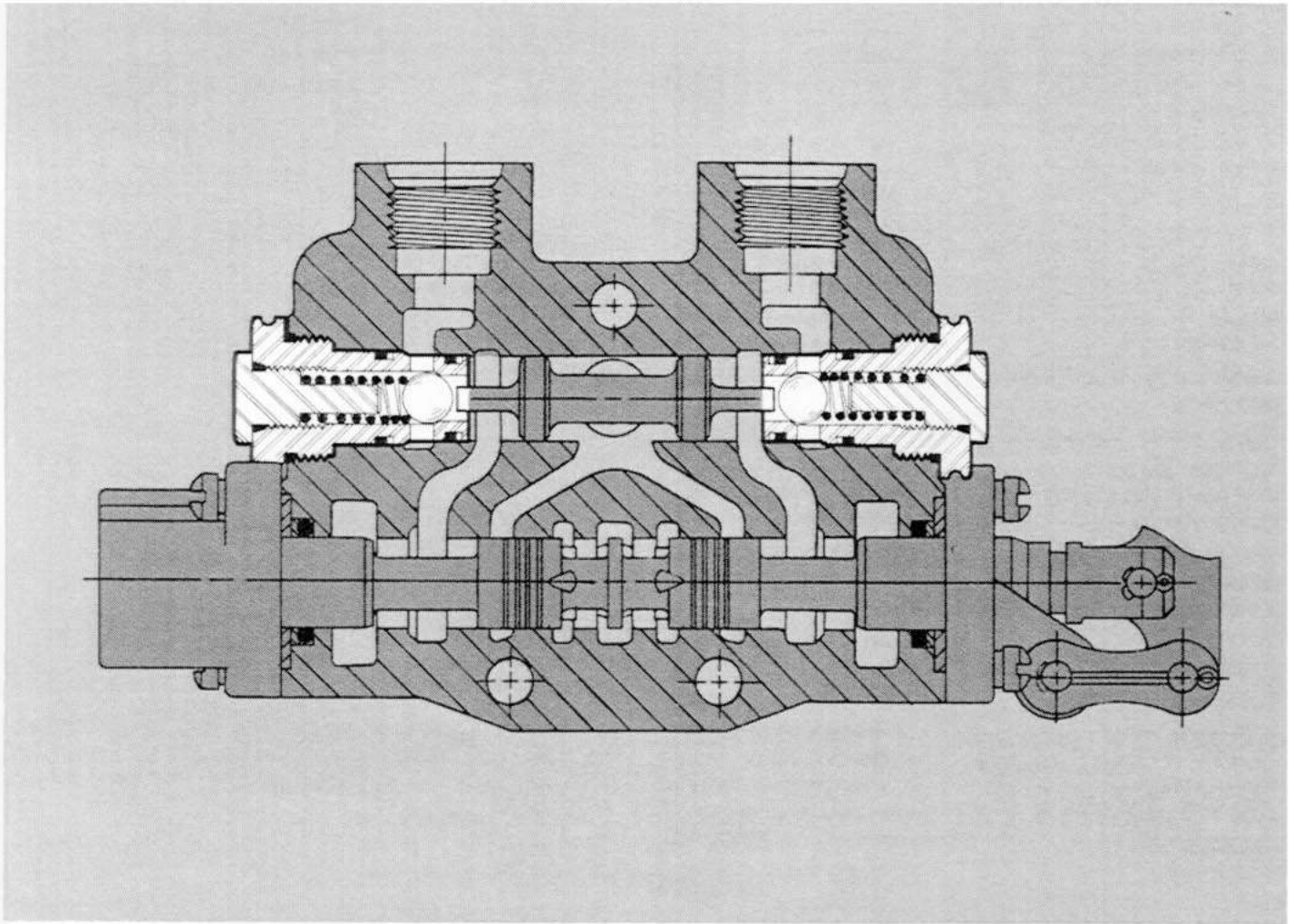

Model V20-LO work sections are designed with double pilot-operated check valves. These pilot operated checks will lock a cylinder or part of a circuit—without leakage—when the control valve spool is in the neutral position. When the spool is shifted to a power position, pressurized oil is directed to one work port. Return oil into the opposite work port is momentarily blocked until pilot pressure unseats the check. Metering characteristics of valve spools are slightly diminished when using these pilot-operated check valves.

These checks are used on applications such as clamps, outriggers, and elevated work platforms where internal fluid leakage could affect the operation of the system. The functions of a 4-Way Section and a pilot-operated check or lock-out in one valve housing are combined in one section.

The spool is a 4-way, 3-position modified free flow spool.

This spool is the same as F4, 4-way, 3-position free flow except the free flow feature is restricted. Free flow prevents any pressure build up between the pump and the pilot operated check when the valve spool is in neutral position.

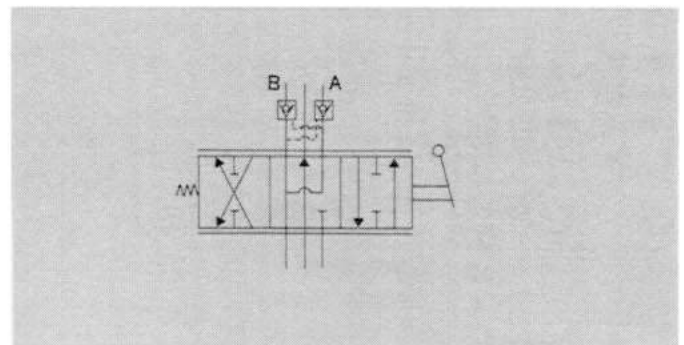

This work section and check valve are combined to perform the functions of a 4-way work section and a pilot-operated check or lockout valve in one single housing.

Combination Work Port Relief Valve and Anti-Cavitation Check

MODEL CRA

At times both a relief valve and an anti-cavitation check are required for the same work port. Both of those functions have been incorporated into one assembly.

Pressure range is: 500-3000 PSI [34-207 bar]

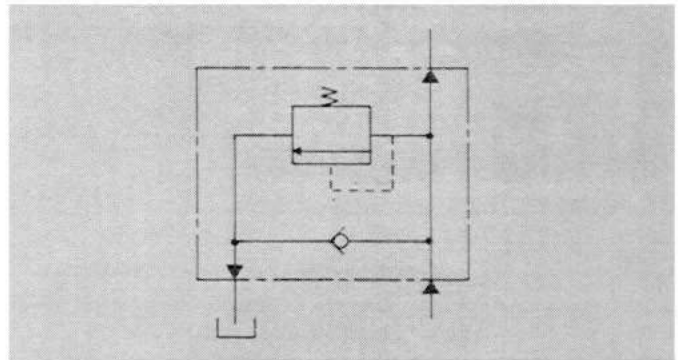
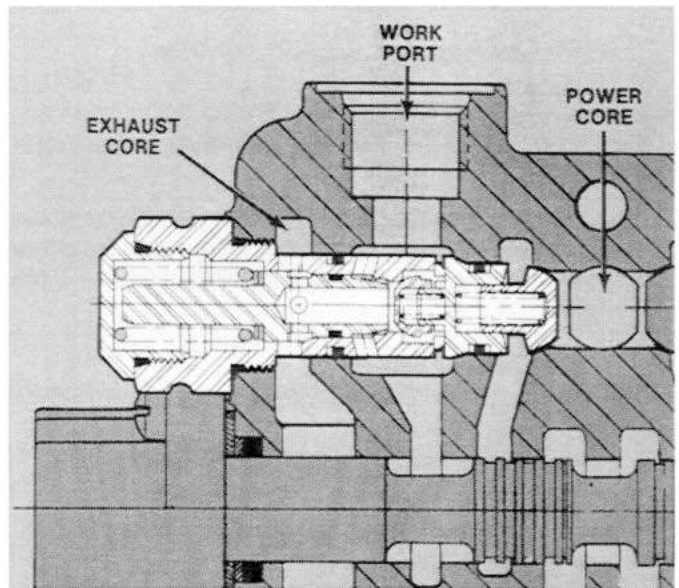

Restrictors

Restrictors may be inserted directly into a SAE work port and will limit oil flow in one direction while allowing free flow in the opposite direction. When restricting flow in the return port, restrictors will:

1. Prevent cylinder or motor cavitation having an inertia load.
2. Provide accurate control of double-acting cylinder by pressurizing both sides of cylinder piston.
3. Restrict oil flow from a hydraulic motor for smoother operation.

When restricting flow in pressure port, restrictors will meter oil flow to provide proper speed of operation.

Work port restrictors are available for SAE 8 and SAE 10 work ports. Nominal orifice diameters are available from .015 to .220 inches [.38 to 5.6 mm]. Specify restrictor hole size desired. Specify whether restrictor should be installed to restrict flow out of the valve work port, or restrict flow into the valve work port.

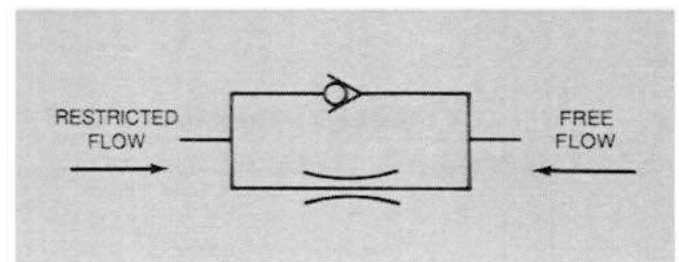
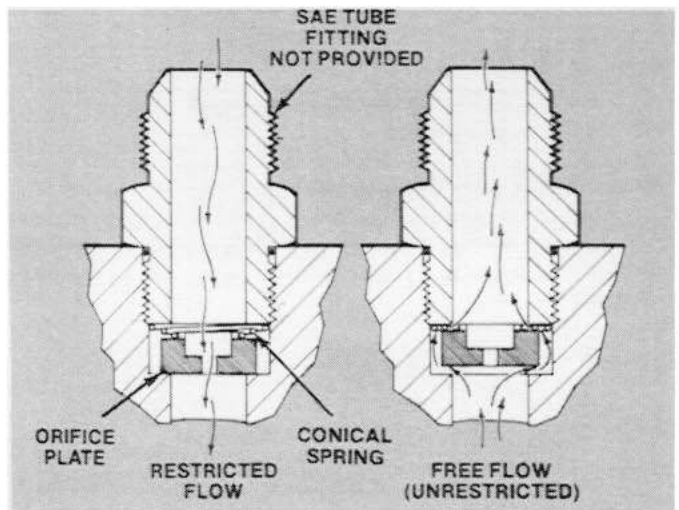

MID-INLET CONVERSION SECTIONS

A mid-inlet conversion section provides an inlet port for a secondary pump downstream in the valve assembly. These sections can be installed between any two work sections thereby providing two different flow paths.

The addition of a mid-inlet section actually combines two separate valve assemblies into one giving them one common tank return line that provides the following advantages:

1. Simplifies installation, reducing plumbing and mounting costs.
2. All valve control handles can be mounted within easy reach.
3. Overall assembly costs are lower than two separate control valves.

Mid-inlet conversion sections are available in the following configurations:

1. Combined Flow Section
2. Split Flow Section
3. Combination 3-Way Work Section and Mid-Inlet Section

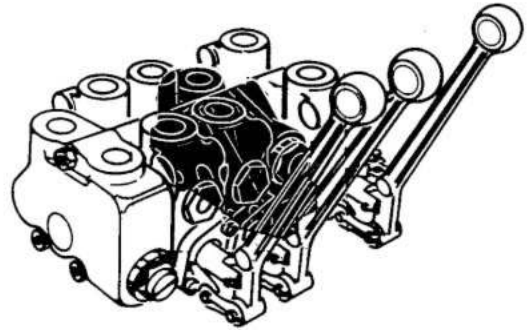

Combined Flow Section

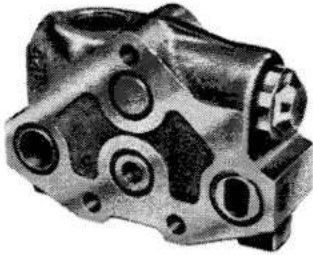

MID-INLET CONVERSION SECTION WITH COMBINED FLOW

When upstream work sections are in the neutral position, the combined flow from both pumps is available to the downstream sections. Combined flow of both pumps cannot exceed the flow capacity of the entire valve.

Split Flow Section

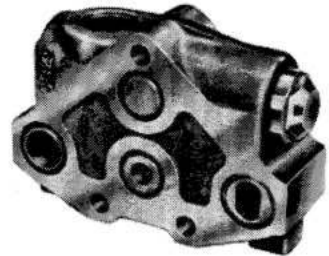

MID-INLET CONVERSION SECTION WITH SPLIT FLOW

Except for a common tank return passage, the split flow section completely separates upstream and downstream work sections. Upstream sections are fed by the primary pump, downstream work sections by the secondary pump.

When ordering a Combined Flow or Split Flow Mid-Inlet Conversion Section be sure to specify:

- Port Size
- Port Location
- Relief Valve Type
- Relief Valve Setting

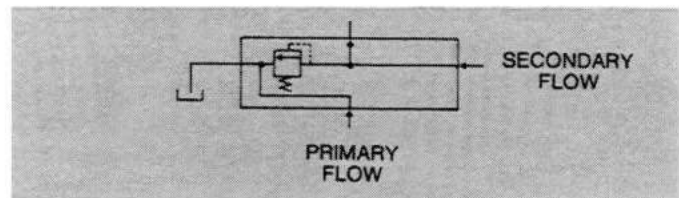
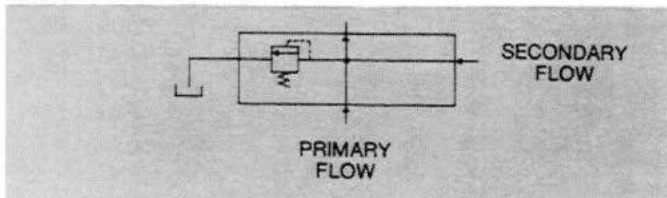

PORTING OPTIONS AVAILABLE (Combined Flow and Split Flow Sections)

LOCATION	NPT PIPE PORTS		SAE STRAIGHT THREAD PORTS	
	STANDARD	OPTIONAL	STANDARD	OPTIONAL
TOP INLET	1/2"-14	3/4"-14	SAE 10 (7/8"- 14 UN)	SAE 12 (1-1/16"- 12 UN)
BACK INLET	1/2"-14	3/4"-14	SAE 10 (7/8"- 14 UN)	SAE 12 (1-1/16"- 12 UN)

Combination 3-Way Work Section and Mid-Inlet Section

A special 3-way spool is used to convert a tandem work section to a combination 3-way work section and mid-inlet section. Port "A", which is normally plugged in a 3-way work section, is used as the mid-inlet port. A modified work port relief valve installed in port "A" serves as the main relief valve for the secondary pump.

This combination section eliminates the need for separate combined flow mid-inlet section, thus reducing the size and weight of the complete valve assembly. It can be used in any V20 open center application where a 3-way section requires a combined flow. Any number of 3-way or 4-way work sections which require a combined flow can be used downstream from this section.

To order, specify Bill of Material No. 1522-8137. Also, specify port size, relief pressure setting and whether clevis is to be located on the "A" or "B" port end.

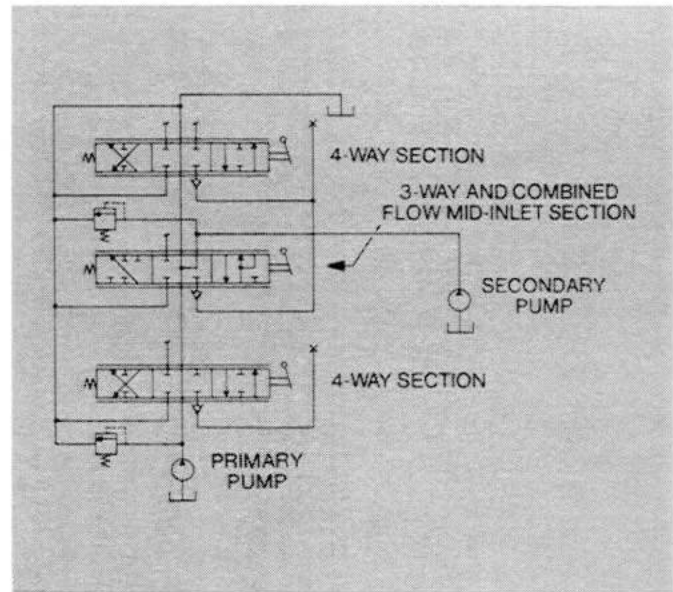

ORDERING OPTIONS FOR MODEL V20P AND V20RP* OPEN CENTER WORK SECTIONS

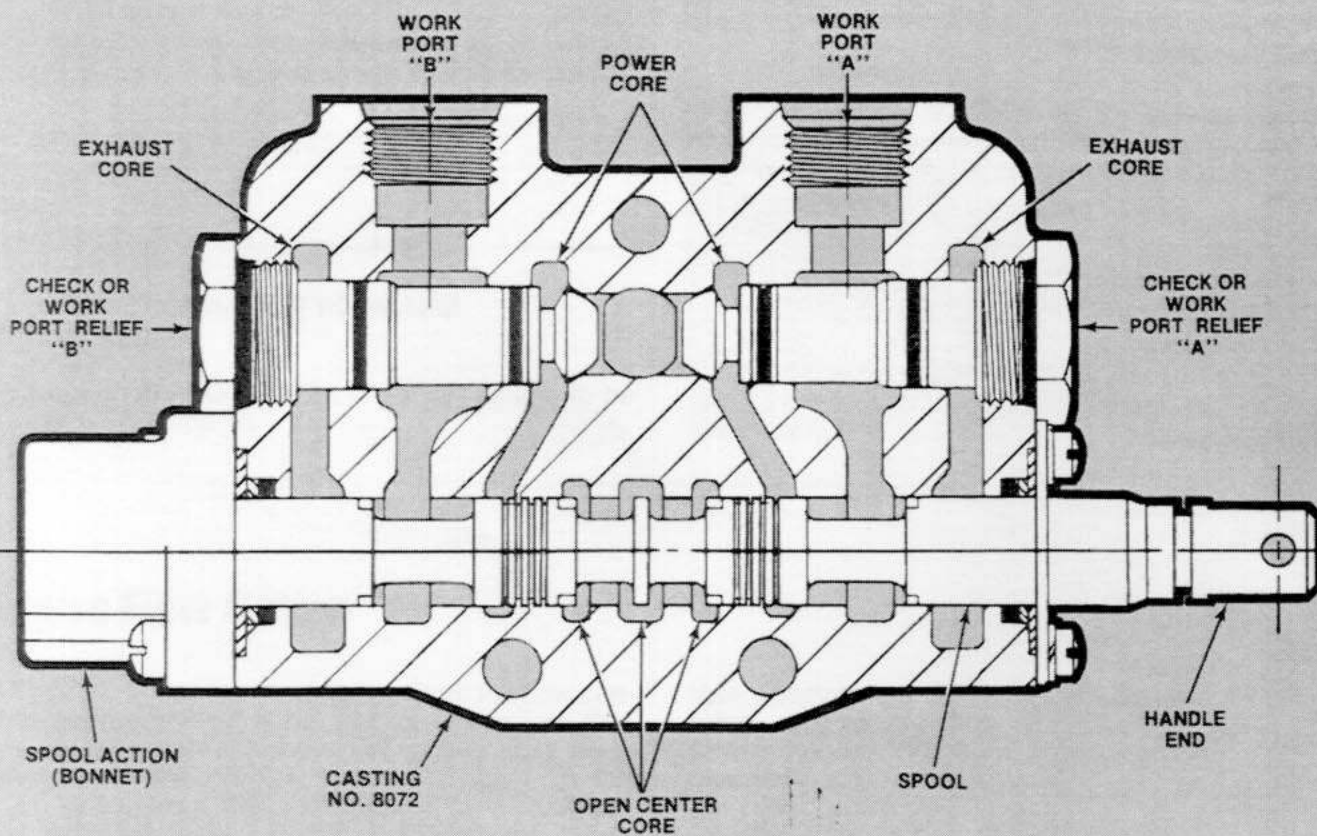

*Reduced open center pressure drop

SPOOL ACTION OPTIONS (BONNET) (Refer to pages 14-19)

	ORDER CODE
Spring Return to Neutral	Furnished as Standard
3-Position Detent, No Spring Centering	D
Detent Stop for Neutral and Spool "IN" or Neutral and Spool "OUT" } Specify	1889 Stop
1-Position Spool "IN" Detent with Spring Return to Neutral	R
1-Position Spool "OUT" Detent with Spring Return to Neutral	RO
2-Position Spool "IN" and "OUT" Detent with Spring Return to Neutral	RIO
Hydraulic Detent Release from "A" or "B" Port	KO
Electro-Magnetic Detent Release	E
4-Way, 4-Position Float Spool	K4
Spring Extended Spool	A
Manual Spool, No Spring Centering or Detent	M
Solenoid Control (Request Catalog No. PC-1104)	—
Hydraulic Remote Actuator	HR, HRO, HRH

SPOOL OPTIONS (Refer to page 13)
Spool option must be specified.

	ORDER CODE
3-Way, 3-Position	3
4-Way, 3-Position	4
3-Way, 3-Position, Free Flow	F3
4-Way, 3-Position, Free Flow	F4
4-Way, 4-Position Float	K4

HANDLE END OPTIONS (Refer to pages 20-21)

Handle end may be located at either "A" or "B" port end. "A" port handle location is furnished as standard. Handles and brackets may be rotated 180° from standard. Handle options must be specified.

Standard Seal Retainer Assembly *	LCHA
Heavy Duty Seal Retainer Assembly	H.D. Retainer
Die Cast Handle Bracket, No. 1801-001	1801 Bracket
Cast Iron Handle Bracket, No. 7355-001	7355 Bracket
Vertical Handle, No. 1802-001 Black Plastic Coating**	CVHA
Horizontal Handle, No. 3249-001 Black Plastic Coating**	CHHA
Spool Wiper, No. 1800-001	1800 Wiper
Spool Boot Assembly	Spool Boots

* Standard Seal Retainer Assembly is limited to 500 PSI [34.5 bar] in the exhaust core, all other options are limited to 1000 PSI [69.0 bar].

**Handles are also available with plain cast iron. (See page 20.)

MODEL V20-LO WORK SECTION OPTION WITH DOUBLE PILOT-OPERATED CHECK (Refer to page 30)

Spool is a 4-way, 3-position with modified free flow.

Overall height of V20-LO casting is 3/32 inch more than standard V20 Casting No. 8072.

Options Available:

- Work port restrictors (SAE ports only)
- Expansion relief valves (refer to catalog No. PC-4000) for "A" or "B" ports (specify pressure setting)

WORK PORT OPTIONS

SIZES: All ports in the same work section must be the same size, they cannot be mixed. Port size must be specified.

THREAD
3/8" - 18 NPT
1/2" - 14 NPT
SAE 8 (3/4" - 16 UN)
SAE 10 (7/8" - 14 UN)
SAE 12 (1-1/16" - 12 UN) (V20RP only)
1/2" BSP

WORK PORT RELIEF VALVES and ANTI-CAVITATION CHECKS (Refer to pages 29-31)

The following relief valves and anti-cavitation checks are installed in "A" and/or "B" work ports. When a 3-way spool is specified, work port nearest handle end is plugged.

	ORDER CODE
Load Check Assembly (Not provided with free flow spools)	Furnished as Standard
Work Port Relief, Differential Poppet	RC
Work Port Relief, Differential Poppet, Adj.	RCA
Work Port Relief, Pilot-Operated, Adjustable	RP20A
Work Port Relief, Pilot-Operated, Non-Adj.	RP20N
Anti-Cavitation Check	AC
Combination-Work Port Relief and Anti-Cavitation Check	CRA
Double Pilot-Operated Check Assembly	V20-LO

Specify relief valve settings required.

Note: If valve is equipped with vertical handle, 1802-001, work port relief valve, Model RCA, which has an extended profile beyond valve body, will interfere with handle. It should NOT be installed on the valve handle end.

RESTRICTORS (Refer to page 31).

Restrictors installed in "A" or "B" ports are available for the following port sizes:

THREAD
SAE 8 (3/4" - 16 UN)
SAE 10 (7/8" - 14 UN)

Specify restrictor hole size desired.

Specify whether restrictor should be installed to restrict flow out of the work port, or restrict flow into the work port.

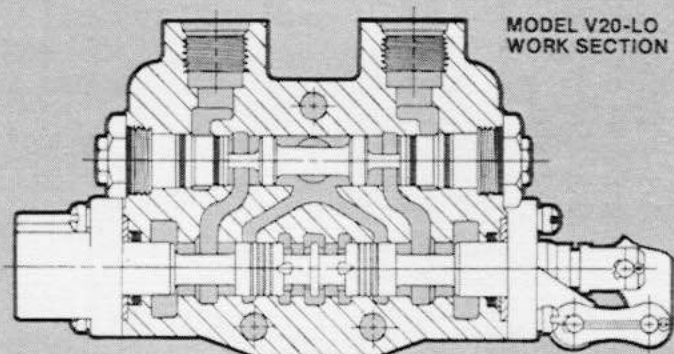

ORDERING OPTIONS FOR MODEL V20T AND V20RT* OPEN CENTER WORK SECTIONS

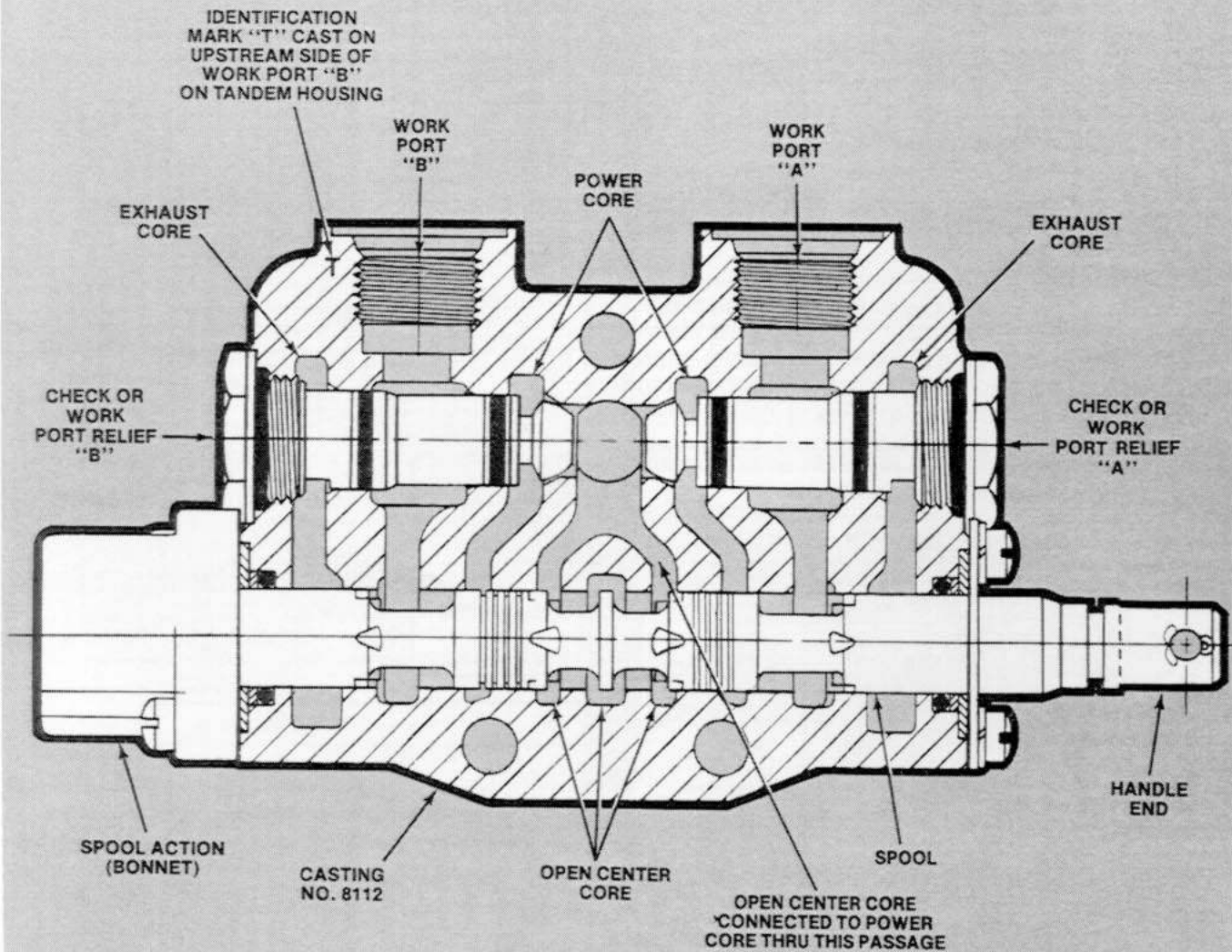

*Reduced open center pressure drop

SPOOL ACTION OPTIONS (BONNET) (Refer to pages 14-19)	
	ORDER CODE
Spring Return to Neutral	Furnished as Standard
3-Position Detent, No Spring Centering	D
Detent Stop for Neutral and Spool "IN" or Neutral and Spool "OUT" Specify	1889 Stop
1-Position Spool "IN" Detent with Spring Return to Neutral	R
1-Position Spool "OUT" Detent with Spring Return to Neutral	RO
2-Position Spool "IN" and "OUT" Detent with Spring Return to Neutral	R/O
Hydraulic Detent Release from "A" or "B" Port	KO
Electro-Magnetic Detent Release	E
4-Way, 4-Position Float Spool	K4
Spring Extended Spool	A
Manual, Spool, No Spring Centering or Detent	M
Solenoid Control	—
Hydraulic Remote Actuator	HR, HRO, HRH

SPOOL OPTIONS (Refer to page 13) Spool option must be specified	
	ORDER CODE
3-Way, 3-Position	3
4-Way, 3-Position	4
3-Way, 3-Position Free Flow	F3
4-Way, 3-Position Free Flow	F4
4-Way, 4-Position Float	K4

HANDLE END OPTIONS (Refer to pages 20-21)	
Handle end may be located at either "A" or "B" port end. "A" port handle location is furnished as standard. Handles and brackets may be rotated 180° from standard. Handle options must be specified.	
Standard Seal Retainer Assembly*	LCHA
Heavy Duty Seal Retainer Assembly	H.D. Retainer
Die Cast Handle Bracket, No. 1801-001	1801 Bracket
Cast Iron Handle Bracket, No. 7355-001	7355 Bracket
Vertical Handle, No. 1802-001 Black Plastic Coating**	CVHA
Horizontal Handle, No. 3249-001 Black Plastic Coating**	CHHA
Spool Wiper, No. 1800-001	1800 Wiper
Spool Boot Assembly	Spool Boots

* Standard Seal Retainer Assembly is limited to 500 PSI [34,5 bar] in the exhaust core, all other options are limited to 1000 PSI [69,0 bar].

**Handles are also available with plain cast iron. (See page 20.)

WORK PORT OPTIONS
SIZES: All ports in the same work section must be the same size, they cannot be mixed. Port size must be specified.
THREAD
3/8" - 18 NPT 1/2" - 14 NPT SAE 8 (3/4" - 16 UN) SAE 10 (7/8" - 14 UN) SAE 12 (1-1/16" - 12 UN) (V20 RT only) 1/2" BSP

WORK PORT RELIEF VALVES and ANTI-CAVITATION CHECKS (Refer to pages 29-31):	
The following relief valves and anti-cavitation checks are installed in "A" and/or "B" work ports. When a 3-way spool is specified, work port nearest handle end is plugged.	
	ORDER CODE
Load Check Assembly (Not provided with free flow spools)	Furnished as Standard
Work Port Relief, Differential Poppet	RC
Work Port Relief, Differential Poppet, Adj.	RCA
Work Port Relief, Pilot-Operated, Adjustable	RP20A
Work Port Relief, Pilot-Operated, Non-Adj.	RP20N
Anti-Cavitation Check	AC
Combination-Work Port Relief and Anti-Cavitation Check	CRA

Specify relief valve settings required.

Note: If valve is equipped with vertical handle, 1802-001, work port relief valve, Model RCA, which has an extended profile beyond valve body, will interfere with handle. It should NOT be installed on the valve handle end.

RESTRICTORS (Refer to page 31)
Restrictors installed in "A" or "B" ports are available for the following port sizes:
THREAD
SAE 8 (3/4" - 16 UN) SAE 10 (7/8" - 14 UN)

Specify restrictor hole size desired.

Specify whether restrictor should be installed to restrict flow out of the work port, or restrict flow into the work port.

ORDERING OPTIONS FOR MODEL V20S OPEN CENTER WORK SECTIONS

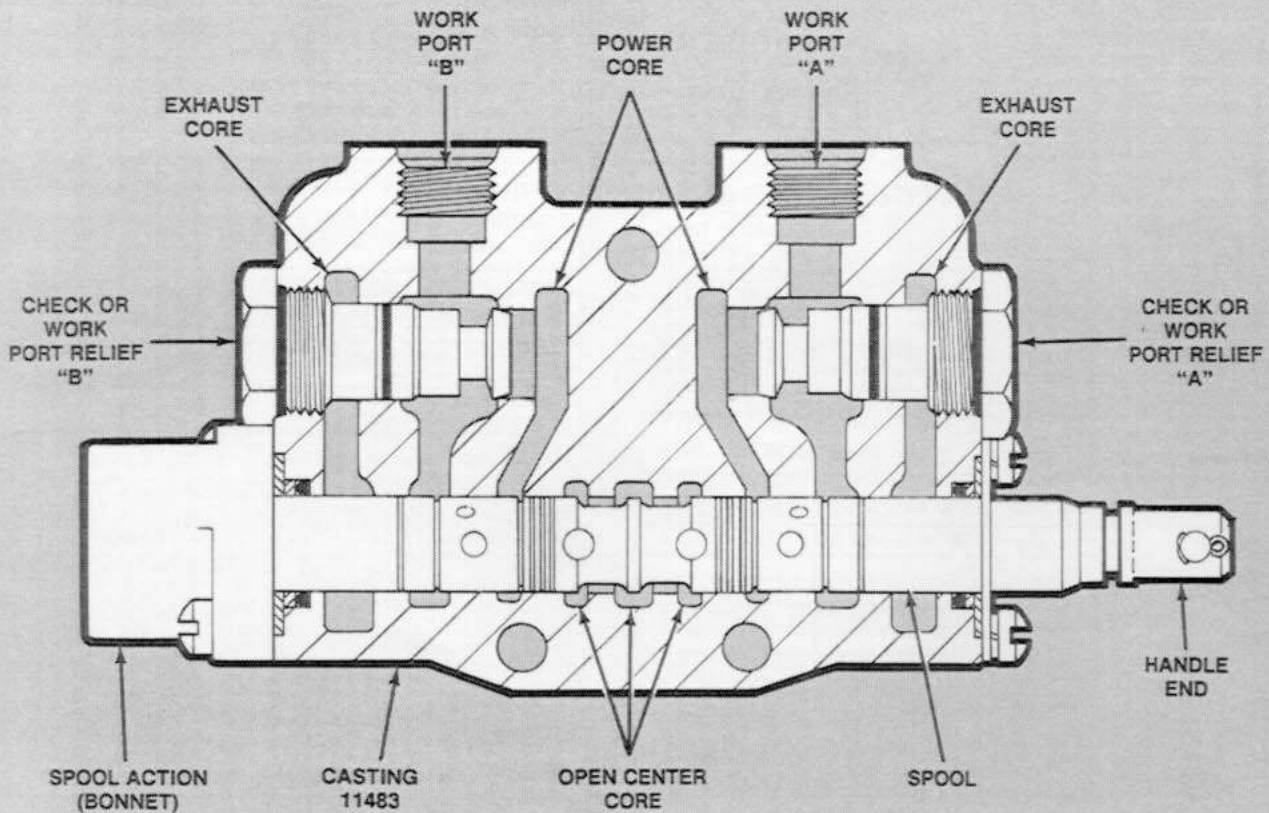

STACKING SEQUENCE RESTRICTIONS

Model V20S series sections may be stacked in a V20P parallel valve assembly allowing series and parallel circuits in the same control valve.

When mixing series and parallel sections in the same stack, a tandem section is always required between the series and parallel sections if the series sections are upstream. If the parallel sections are upstream, then the series sections may

be stacked directly downstream of a parallel section.

When assembling or specifying V20S series sections in a stack, it is not necessary to have a V20S section as the last section in the stack unless series flow is required through a power beyond sleeve to a downstream valve.

SPOOL ACTION OPTIONS (BONNET) (Refer to pages 14-19)	
	ORDER CODE
Spring Return to Neutral	Furnished as Standard
3-Position Detent, No Spring Centering	D
Detent Stop for Neutral and Spool "IN" or Neutral and Spool "OUT" Specify	1889 Stop
1-Position Spool "IN" Detent with Spring Return to Neutral	R
1-Position Spool "OUT" Detent with Spring Return to Neutral	RO
2-Position Spool "IN" and "OUT" Detent with Spring Return to Neutral	RIO
Hydraulic Detent Release from "A" or "B" Port	KO
Electro-Magnetic Detent Release	E
4-Way, 4-Position Float Spool	K4
Spring Extended Spool	A
Manual, Spool, No Spring Centering or Detent	M
Solenoid Control	—
Hydraulic Remote Actuator	HR, HRO, HRH

SPOOL OPTIONS (Refer to page 13) Spool option must be specified	
	ORDER CODE
3-Way, 3-Position	3
4-Way, 3-Position	4
3-Way, 3-Position Free Flow	F3
4-Way, 3-Position Free Flow	F4
4-Way, 4-Position Float	K4

HANDLE END OPTIONS (Refer to pages 20-21)	
Handle end may be located at either "A" or "B" port end. "A" port handle location is furnished as standard. Handles and brackets may be rotated 180° from standard. Handle options must be specified.	
Standard Seal Retainer Assembly*	LCHA
Heavy Duty Seal Retainer Assembly	H.D. Retainer
Die Cast Handle Bracket, No. 1801-001	1801 Bracket
Cast Iron Handle Bracket, No. 7355-001	7355 Bracket
Vertical Handle, No. 1802-001 Black Plastic Coating**	CVHA
Horizontal Handle, No. 3249-001 Black Plastic Coating**	CHHA
Spool Wiper, No. 1800-001	1800 Wiper
Spool Boot Assembly	Spool Boots

*Standard Seal Retainer Assembly is limited to 500 PSI [34.5 bar] in the exhaust core, all other options are limited to 1000 PSI [69.0 bar].

**Handles are also available with plain cast iron. (See page 20.)

WORK PORT OPTIONS
SIZES: All ports in the same work section must be the same size, they cannot be mixed. Port size must be specified.
THREAD
3/8" - 18 NPT 1/2" - 14 NPT SAE 8 (3/4" - 16 UN) SAE 10 (7/8" - 14 UN) 1/2" BSP

WORK PORT RELIEF VALVES and ANTI-CAVITATION CHECKS (Refer to pages 29-31)	
The following relief valves and anti-cavitation checks are installed in "A" and/or "B" work ports. When a 3-way spool is specified, work port nearest handle end is plugged.	
	ORDER CODE
Load Check Assembly (Not provided with free flow spools)	Furnished as Standard
Work Port Relief, Differential Poppet	RC
Work Port Relief, Differential Poppet, Adj.	RCA
Work Port Relief, Pilot-Operated, Adjustable	RP20A
Work Port Relief, Pilot-Operated, Non-Adj.	RP20N
Anti-Cavitation Check	AC
Combination Work Port Relief and Anti-Cavitation Check	CRA

Specify relief valve settings required.

Note: If valve is equipped with vertical handle, 1802-001, work port relief valve, Model RCA, which has an extended profile beyond valve body, will interfere with handle. It should NOT be installed on the valve handle end.

RESTRICTORS (Refer to page 31)
Restrictors installed in "A" or "B" ports are available for the following port sizes:
THREAD
SAE 8 (3/4" - 16 UN) SAE 10 (7/8" - 14 UN)

Specify restrictor hole size desired.

Specify whether restrictor should be installed to restrict flow out of the work port, or restrict flow into the work port.

V20P, V20T or V20PT OPEN CENTER PRESSURE DROP

Left End In
To Left End Out

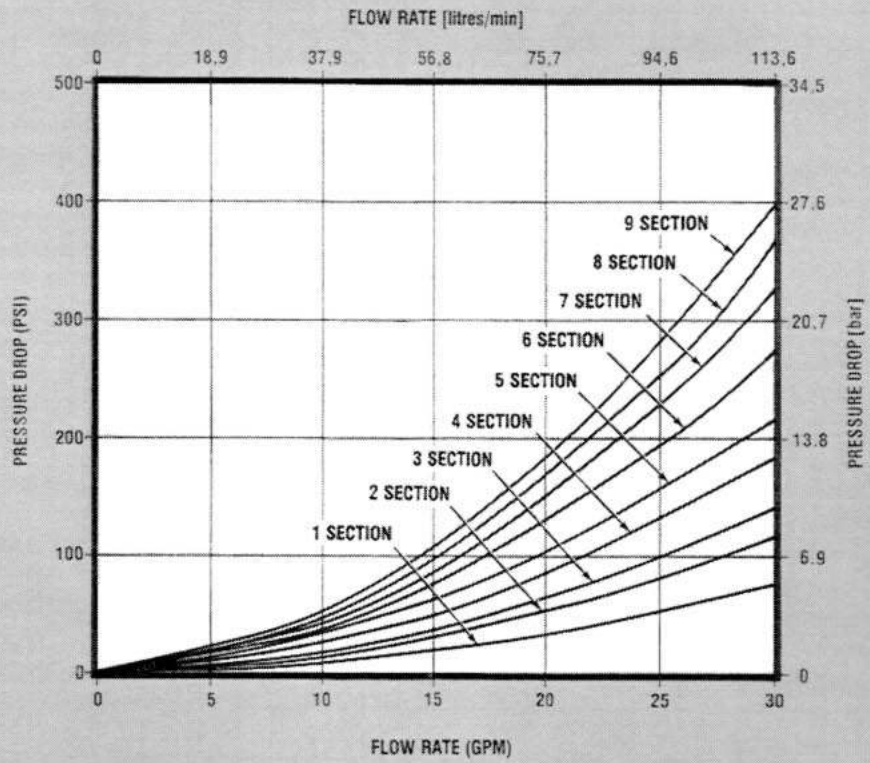

Left End In
To Right End Out

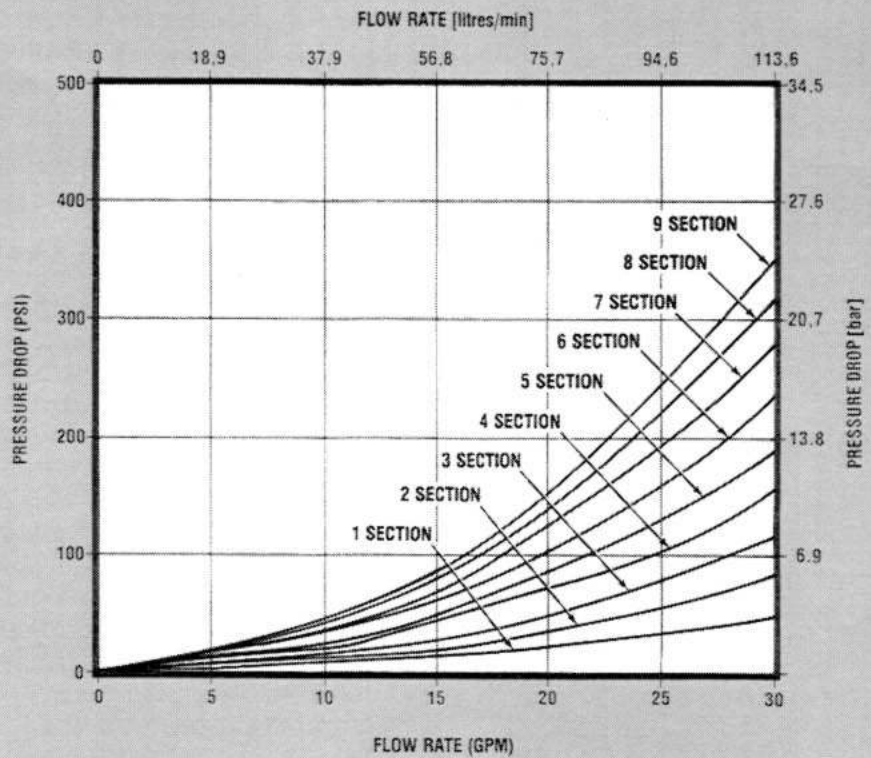

Curves derived from actual laboratory tests run with 150 SUS oil, at 100°F [38°C].
SAE 12 inlet and outlet ports, and SAE 10 work ports.

V20P, V20T or V20PT INTERNAL PRESSURE DROP

Left End In To
Work Ports "A" or "B"

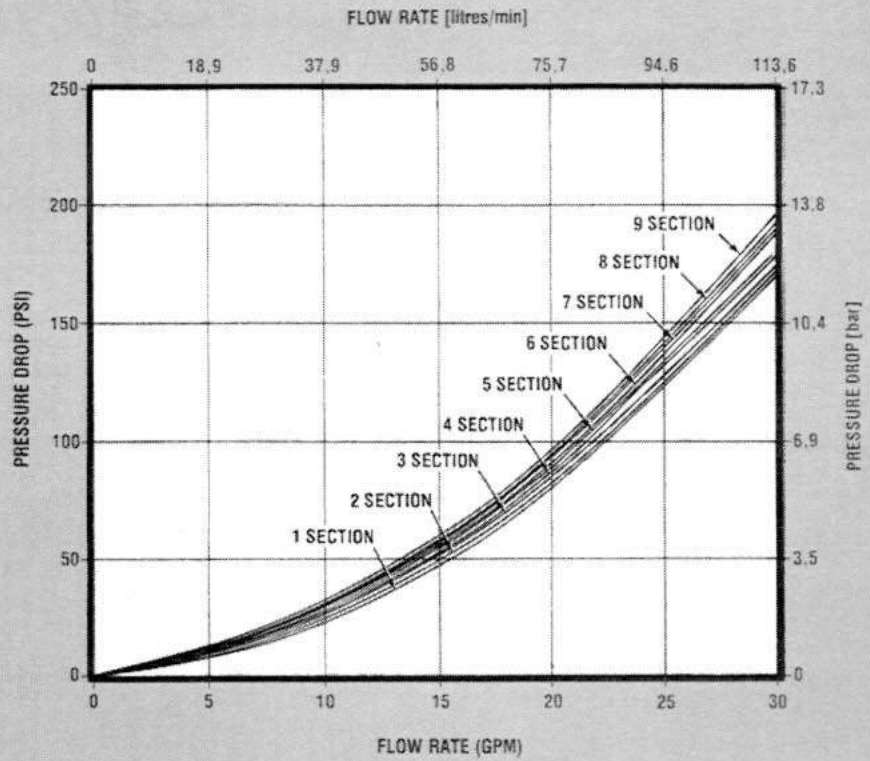

Curves derived from actual laboratory tests run with 150 SUS oil, at 100°F [38°C].
SAE 12 inlet and outlet ports, and SAE 10 work ports.

V20P, V20T or V20PT INTERNAL PRESSURE DROP

Work Port "A"
To Right End Outlet

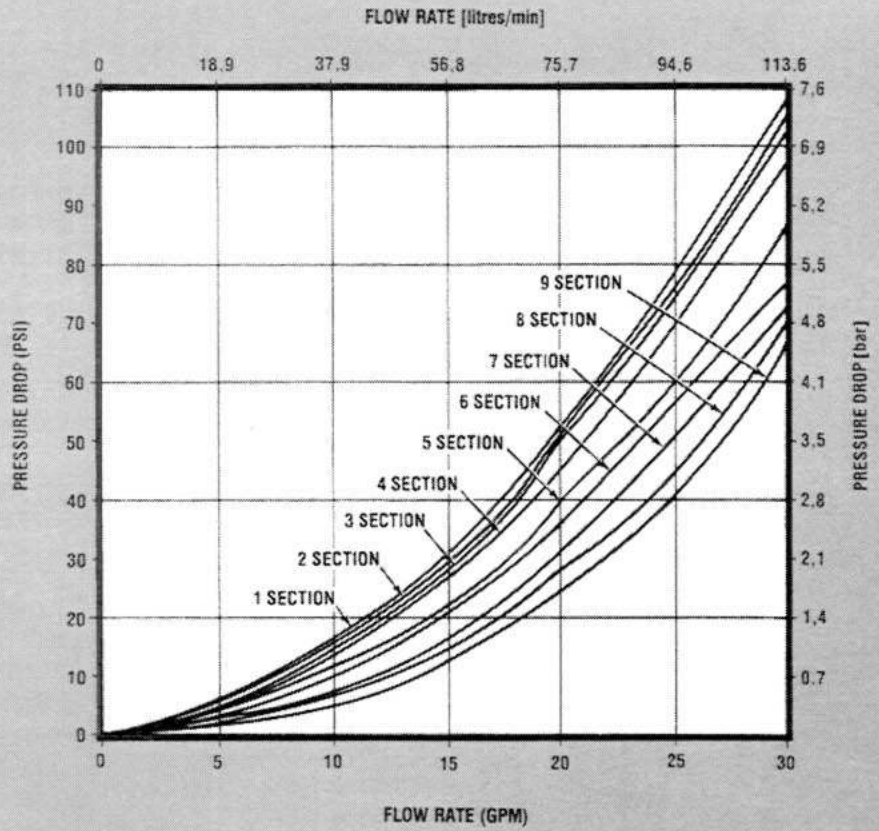

Work Port "B"
To Right End Outlet

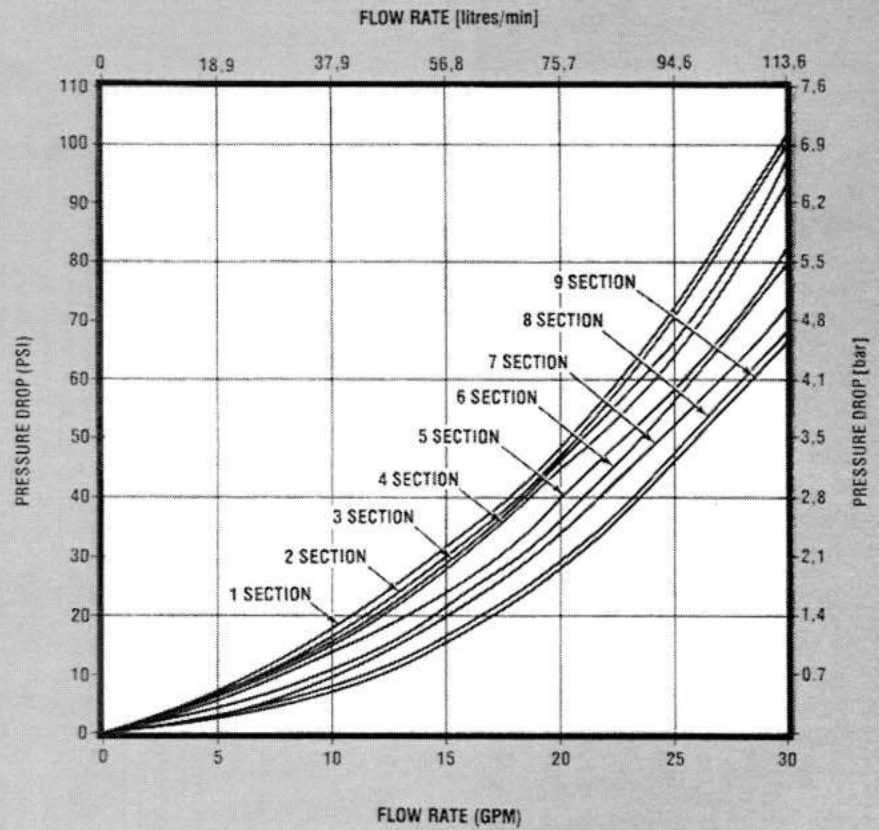

Curves derived from actual laboratory tests run with 150 SUS oil, at 100°F [38°C].
SAE 12 inlet and outlet ports, and SAE 10 work ports.

V20P, V20T or V20PT INTERNAL PRESSURE DROP

Work Port "A"
To Left End Outlet

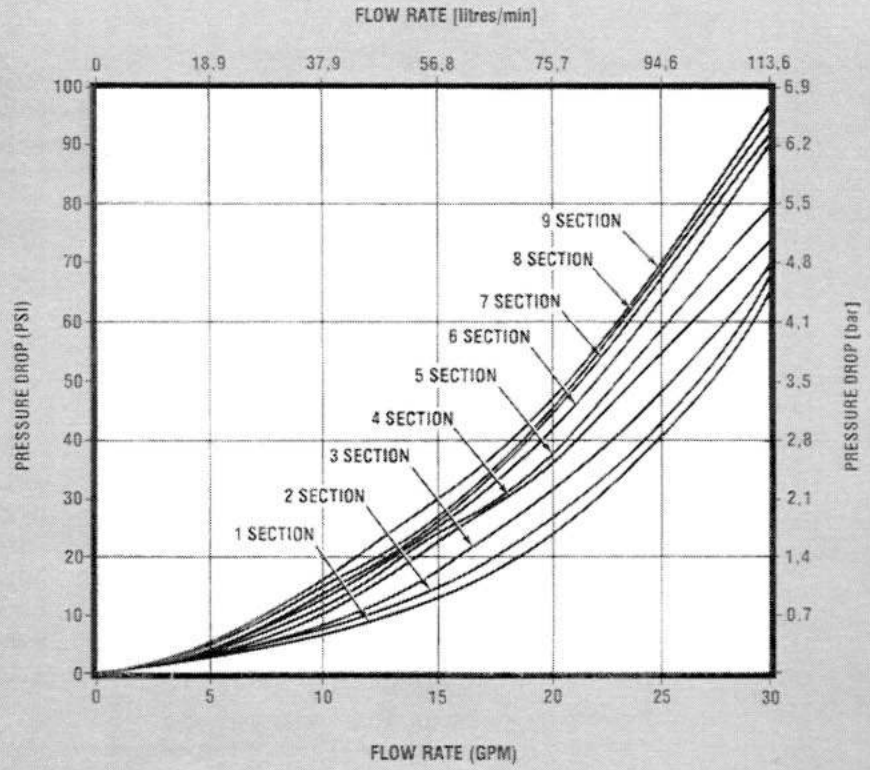

Work Port "B"
To Left End Outlet

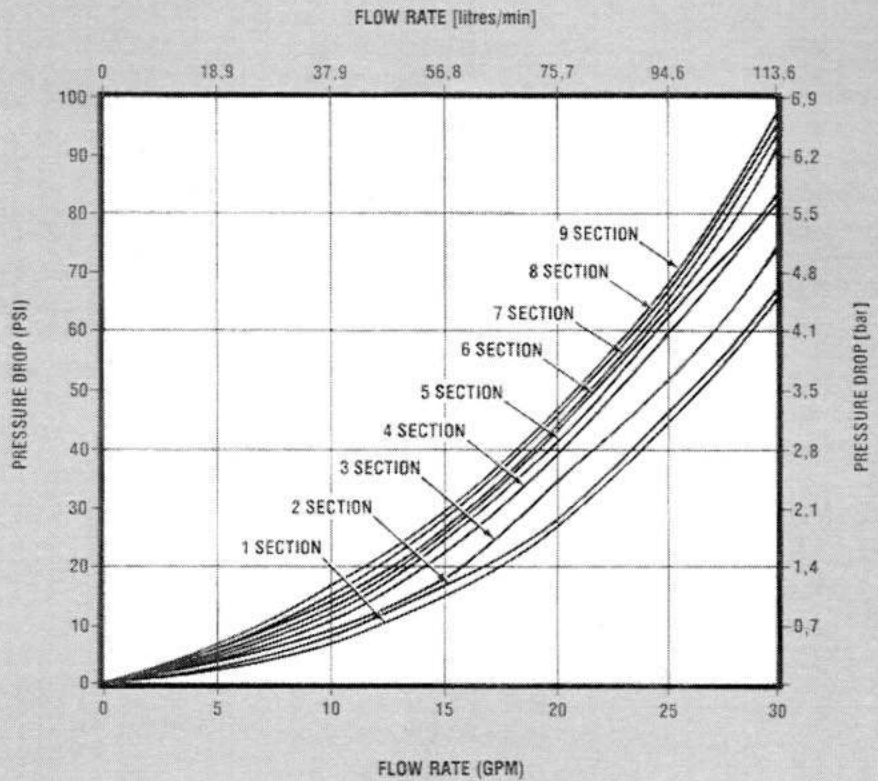

Curves derived from actual laboratory tests run with 150 SUS oil, at 100°F [38°C].
SAE 12 inlet and outlet ports, and SAE 10 work ports.

V20S (SERIES) OPEN CENTER PRESSURE DROP

Left Top Inlet
To Left Top Outlet

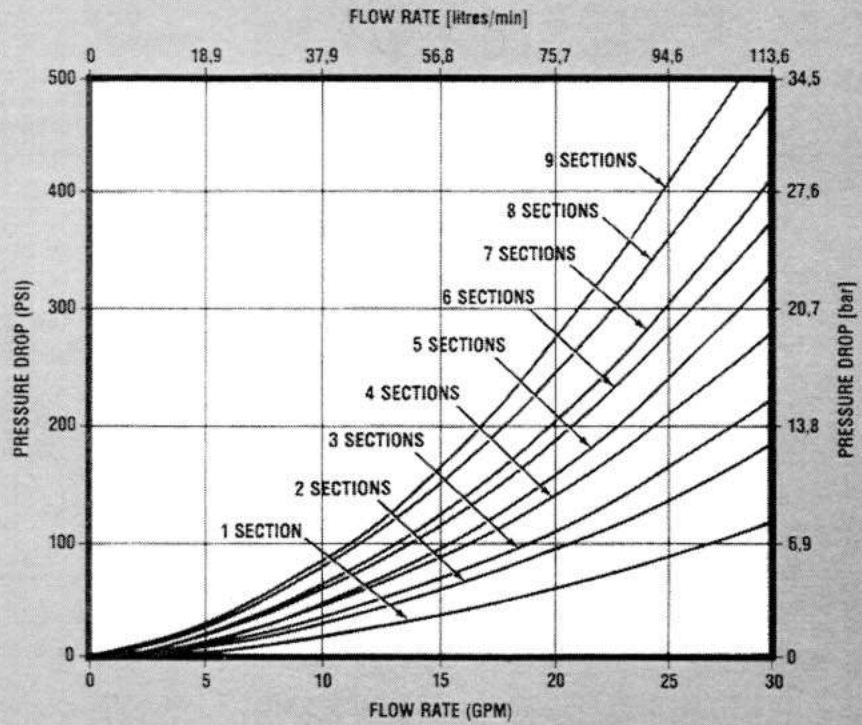

Left Top Inlet
To Right End Outlet

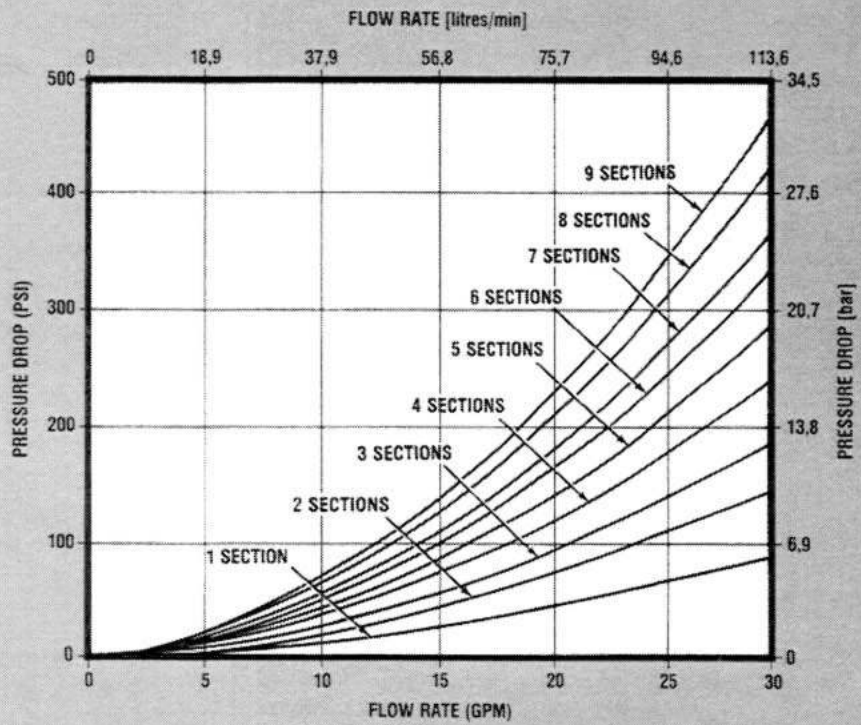

Curves derived from actual laboratory tests run with 150 SUS oil, at 100°F [38°C].
SAE 12 inlet and outlet ports, and SAE 10 work ports.

V20S (SERIES) INTERNAL PRESSURE DROP

Left Top Inlet
To Work Port "A"

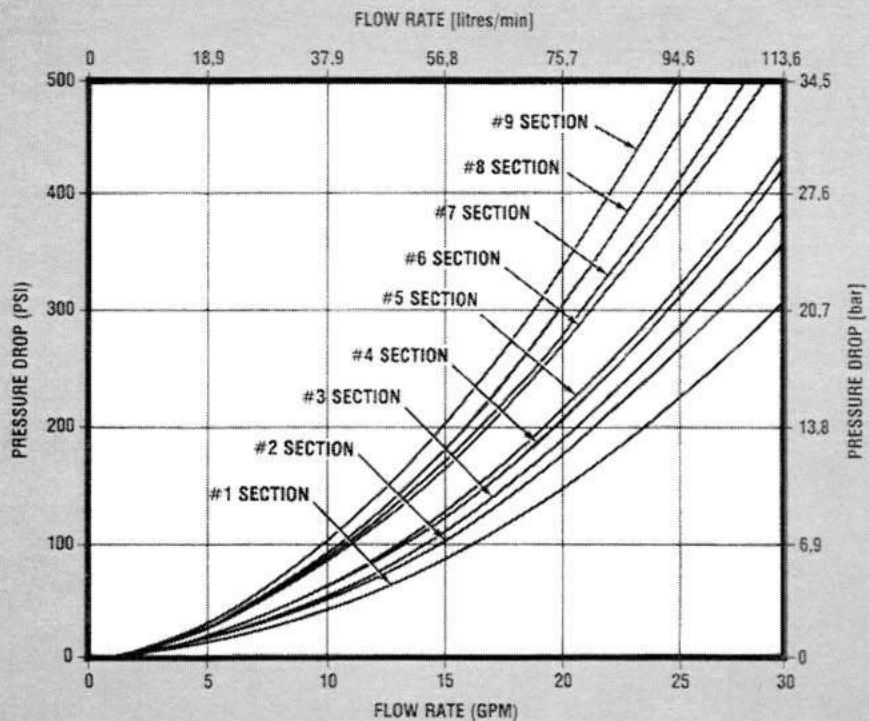

Left Top Inlet
To Work Port "B"

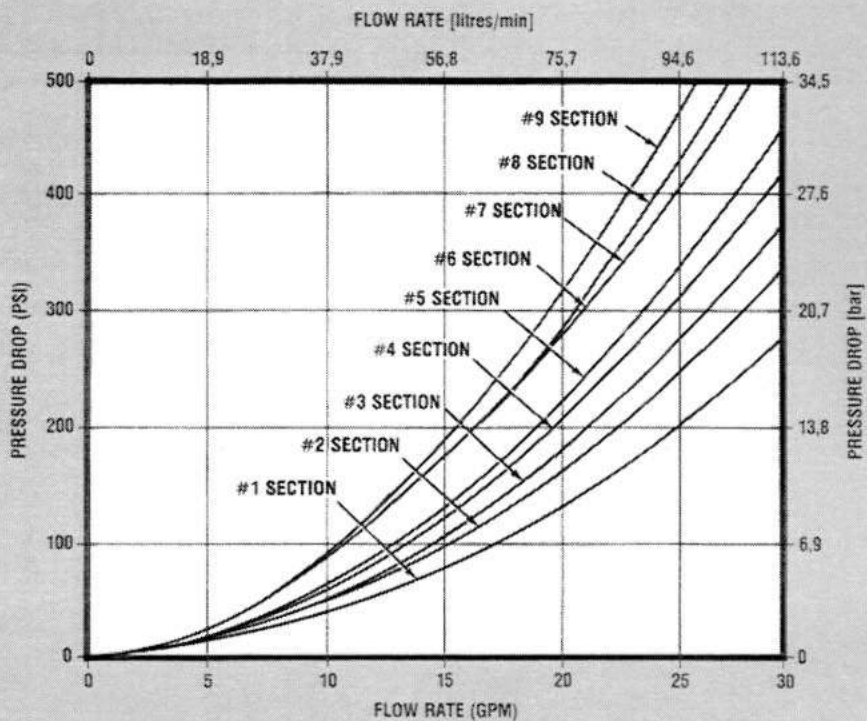

Curves derived from actual laboratory tests run with 150 SUS oil, at 100°F [38°C].
SAE 12 inlet and outlet ports, and SAE 10 work ports.

V20S (SERIES) INTERNAL PRESSURE DROP

Work Port "A"
To Right End Outlet

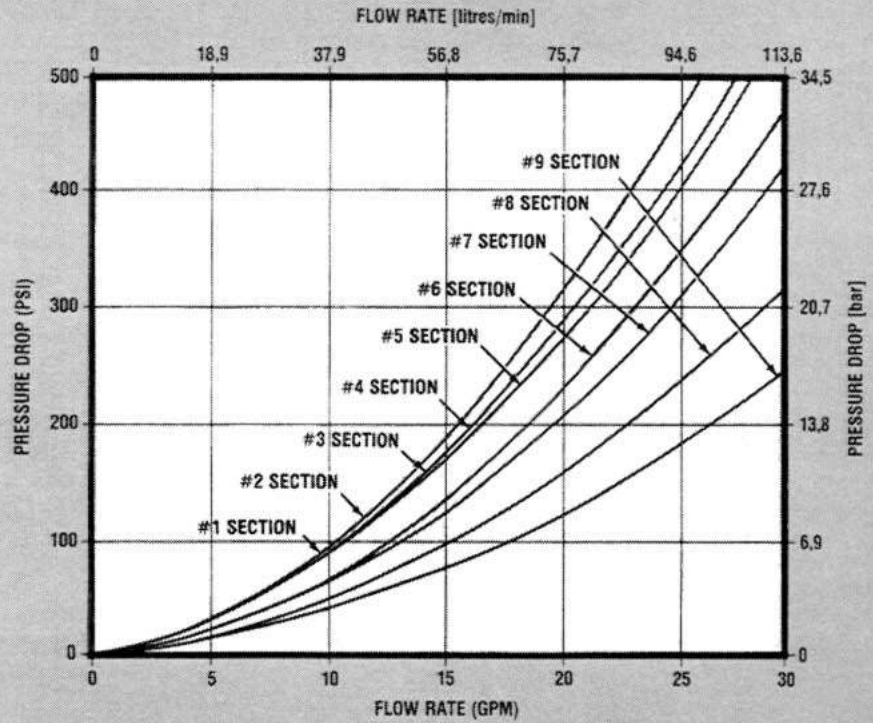

Work Port "B"
To Right End Outlet

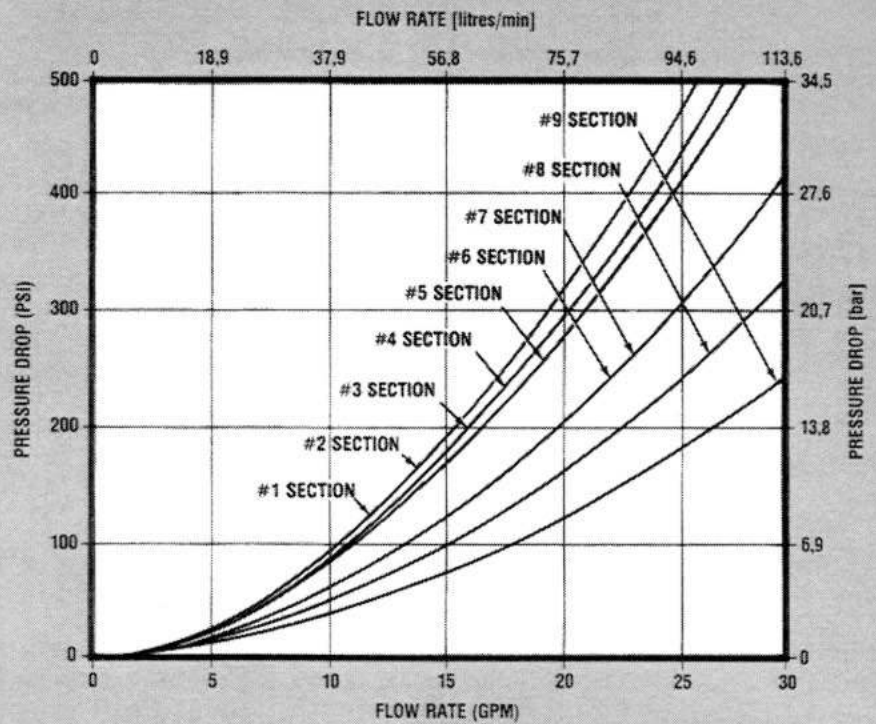

Curves derived from actual laboratory tests run with 150 SUS oil, at 100°F [38°C].
SAE 12 inlet and outlet ports, and SAE 10 work ports.

V20S (SERIES) INTERNAL PRESSURE DROP

Work Port "A" or "B"
To Left End Outlet

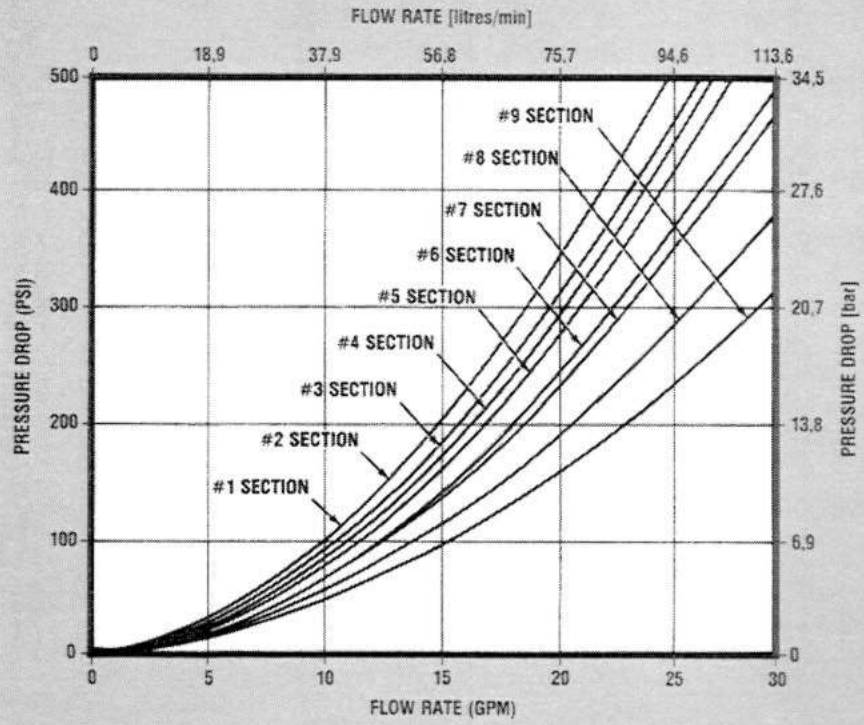

Curves derived from actual laboratory tests run with 150 SUS oil, at 100°F [38°C].
SAE 12 inlet and outlet ports, and SAE 10 work ports.

DIMENSIONS: TYPICAL MODEL V20P, V20T, V20PT, OR V20S VALVE ASSEMBLY

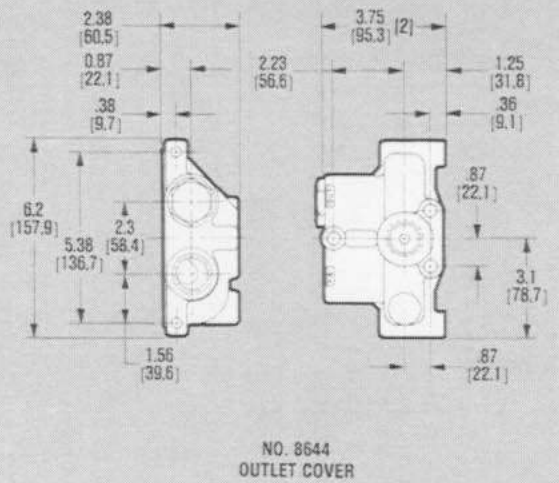
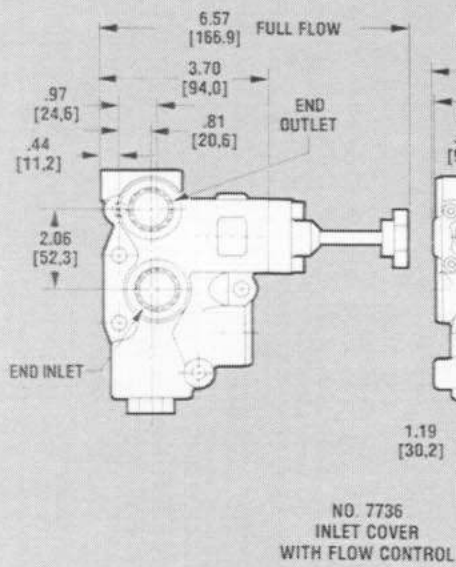
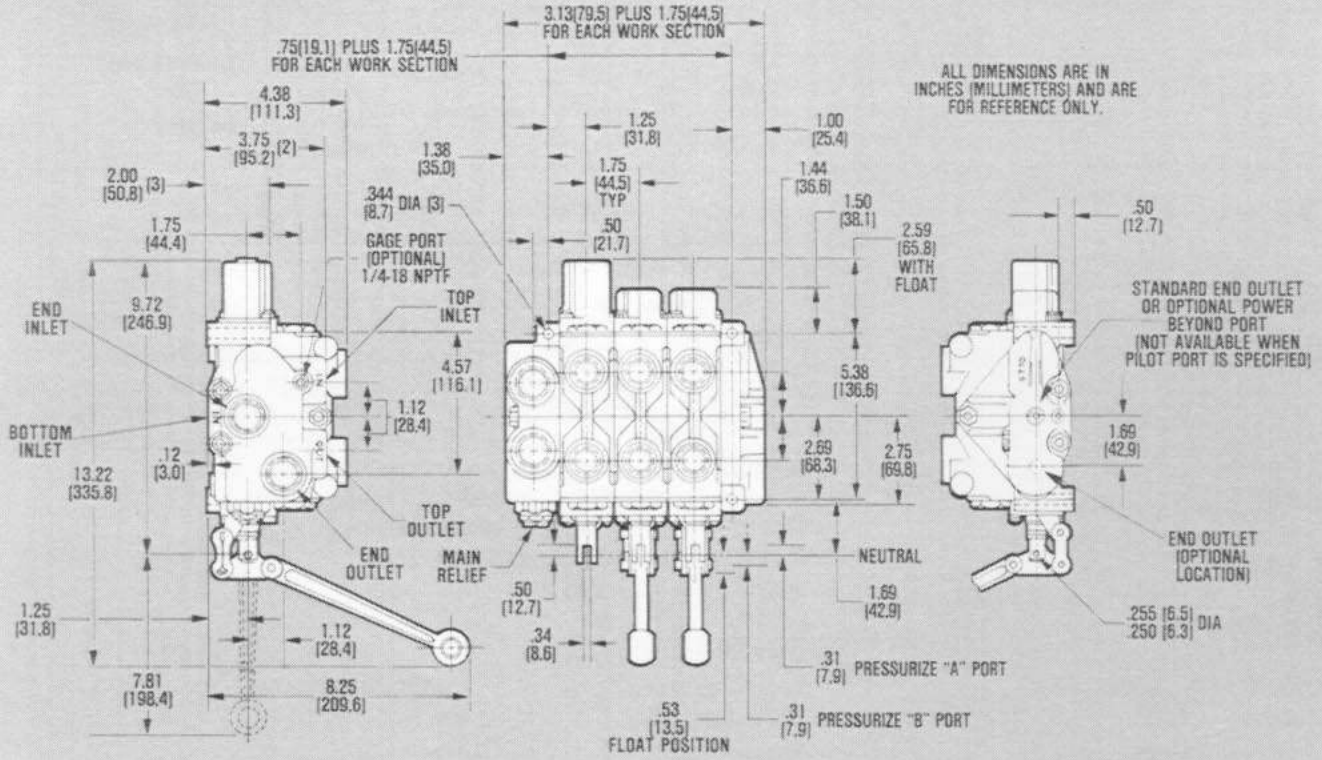

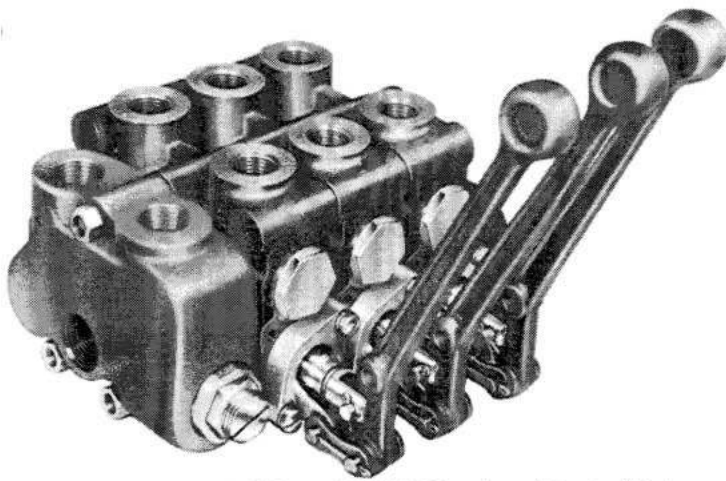

CLOSED CENTER VALVE ASSEMBLIES

Models V20C and V20LS

Gresen's Models V20C and V20LS Directional Control Valves are available for parallel, hydraulic circuit applications, up to 3500 PSI [242 bar] continuous operating pressure. New spool designs have resulted in lighter spool actuating effort making their finger-tip touch and extra-fine metering characteristics ideal for back hoe, front end loader and personnel lift applications. This sensitivity also gives the design engineer a wider latitude of mechanical linkage possibilities.

Service or conversion is simple since individual sections can be added, removed or replaced in the field. Individual service or field conversion sections, rather than complete valve assemblies, can be stocked thus reducing inventories.

The Model V20C Directional Control Valve is designed specifically for high standby pressure, closed center systems. The

Model V20LS Directional Control Valve is designed specifically for low standby pressure, closed center systems with load sensing.

Normally, an open center valve may be converted to a closed center valve by plugging the open center core in the outlet cover. Under these conditions, the valve's power core is exposed to high pressure at all times. Leakage may then occur past the valve spool and on into the work port area and cause a cylinder to extend while the valve spool is in neutral position. High pressure build-up at the work port in the Models V20C and V20LS is prevented by installing an anti-drift cartridge. Refer to work port options on page 51.

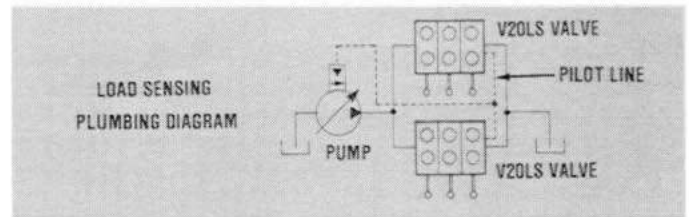
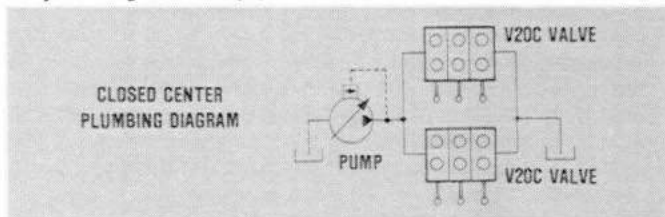

APPLICATIONS

Two or more Directional Control Valve Assemblies may be supplied from a single, variable displacement pump in the hydraulic system by using a "tee" arrangement. The power beyond option normally available with open center valves is not required for Model V20C or V20LS work sections since neither work section has an open center core.

FEATURES

- Minimal spool actuating effort — Maximum, 50 pounds [23 kg] at the spool
- Improved, extra-fine metering
- Valve housings made of high tensile cast iron for durability and resistance to shock loads.
- Spools are hard, chrome plated for long life and corrosion resistance.

SPECIFICATIONS

Pressure Rating:

Continuous Operating 3500 PSI [242 bar] max.

Capacity:

Nominal Flow 20 GPM [76 litres/min]

Maximum Flow 30 GPM [114 litres/min]

Maximum Exhaust Core Pressure:

With Handle Bracket or Heavy Duty

Spool Seal Retainer Installed

Continuous Operating 500 PSI [34,5 bar]

Intermittent Peak 1000 PSI [69,0 bar]

With Standard Spool Seal Retainer

Installed 200 PSI [13,8 bar]

Filteration Required (Min.) 33 micrometre

Weight:

Inlet Cover Approx. 6 lbs. [2,7 kg]

Outlet Cover Approx. 3½ lbs. [1,6 kg]

Work Section, Each Approx. 9 lbs. [4,1 kg]

V20C/V20LS SECTIONAL VIEW

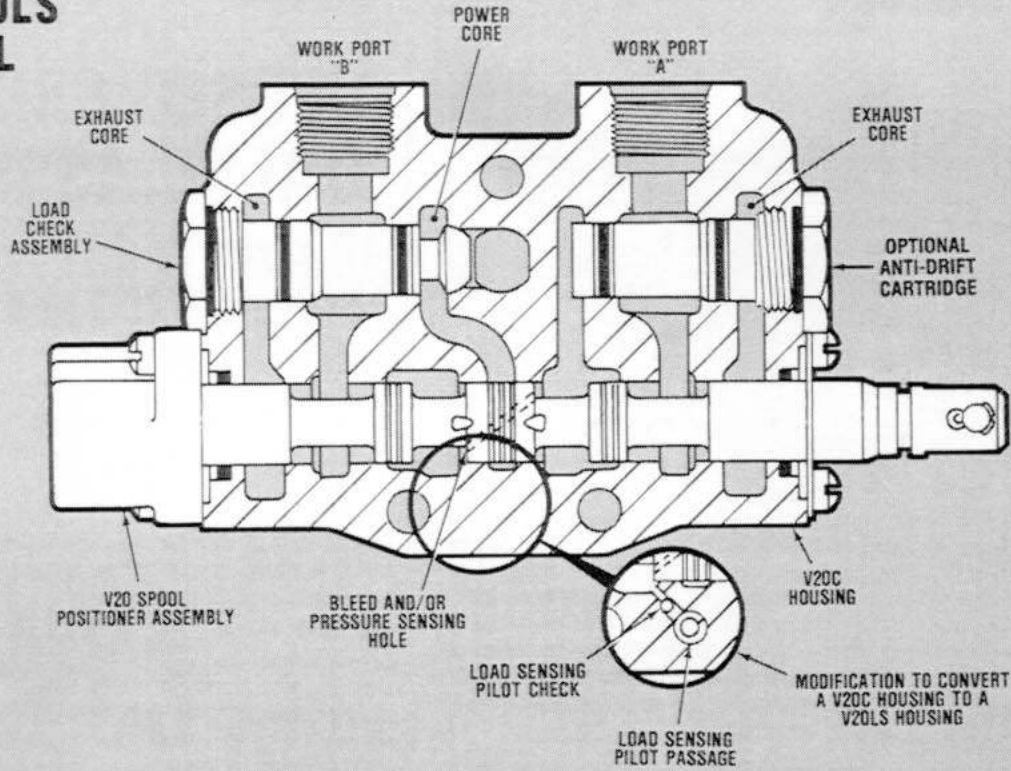

VALVE METERING

Closed Center Systems

Valve spool metering is improved because the volume of oil is controlled by the metering notches at a constant pressure drop across the spool. The pump displacement will self-adjust to maintain full system pressure thus creating this constant pressure drop across the spool. Controlling flow across spool metering notches is improved when the pressure drop remains constant.

INLET COVER

Part No. 8398-

The inlet cover is designed to provide a variety of port sizes and locations. This permits valve assemblies to be "customized" using a minimum of external plumbing. For information regarding main system relief valves, refer to pages 10 and 11.

OUTLET COVER

Part No. 6770-

The outlet cover provides an end outlet port. It also provides for a pilot port in load sensing systems. If the outlet port and the pilot port are both required in the outlet cover, the outlet port will be furnished in the optional location. (Refer to illustration.)

A pilot drain option is available for the load sensing outlet cover. This option is required in a load sensing system when a pilot drain orifice is not provided in the pressure compensated pump. The pilot drain orifice relieves the load sensing pilot pressure in the pump compensator after the control valve spool is returned to neutral. It is necessary to relieve this pressure signal in order for the pump to return to its standby pressure setting.

Closed Center Systems with Load Sensing

Valve spool metering is further improved since pump pressure is maintained at the slightly higher standby pressure (150 to 250 PSI [10 to 17 bar]) than is required by the function. This fixed pressure drop remains the same from minimum to maximum load requirements in contrast to the conventional closed center system.

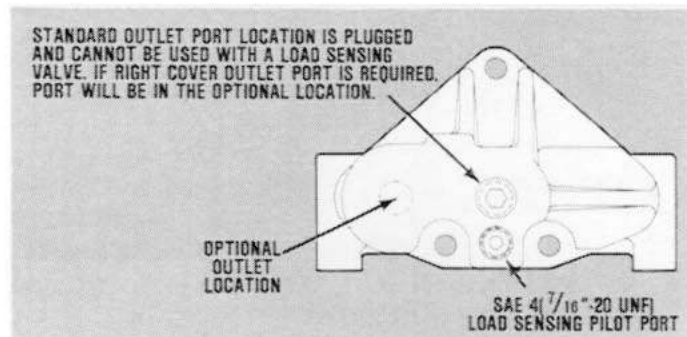

For plumbing convenience, the outlet port may be located in the inlet (left) cover. When it is, a "turnaround" (right) cover will direct exhausting oil back to the inlet cover.

A power beyond option is not available since there is no open center core in V20C or V20LS work sections.

SPOOL ACTION OPTIONS and HANDLE END OPTIONS

The Models V20C and V20LS work sections are available with the same spool action options and handle end options as of-

ferred for the Model V20P except V20LS float option can not be reversed in the housing.

Spool Action Options

Refer to pages 14 through 19.

	CODE SYMBOL		CODE SYMBOL
Spring Return to Neutral (Standard)	—	Hydraulic Remote Spool Actuator *	HR
3-Position Detent	D	Hydraulic Remote Spool Actuator (Manual Override)*	HRO
No. 1889-001 Detent Stop	—	(Request Catalog No. PC-1103)	
4-Position Float	K4		
1-Position, Spool "IN" Detent	R		
1-Position, Spool "OUT" Detent	RO		
2-Position, Spool "IN" and "OUT" Detent	RIO		
Spring Extended Spool	A		
Manual	M		
Internal Pressure Detent Release	KO		
Electro-Mechanical Detent Release	E		
Solenoid Control (Request Catalog No. PC-1104)	—		

* Pilot Pressure For Remote Actuators
300 PSI [21 bar] is required to actuate either Gresen's Solenoid or Hydraulic Remote Actuator Assemblies. This may be accomplished by installing a pressure reducing valve at the pump discharge and plumbing the lower pressure hydraulic fluid to the Remote Actuator Assemblies.

When the system has load sensing, standby pressure must be increased to 300 PSI [21 bar].

Handle and Handle End Options

Refer to pages 20 and 21.

	CODE SYMBOL		CODE SYMBOL
Complete Vertical Handle Assembly	CVHA	Heavy Duty Spool Seal Retainer Assembly, No. K-6029	—
Complete Horizontal Handle Assembly	CHHA	Spool Wiper, No. 1800-001	—
Die Cast Handle Bracket, No. 1801-001	—	Spool Boot Assembly, No. K-6056	—
Cast Iron Handle Bracket, No. 7355-001	—	Less Handle Only	LHO
Standard Spool Seal Retainer Assembly, No. K-6033	—	Less Complete Handle Assembly	LCHA

SPOOL VARIATIONS

Refer to page 13.

	CODE SYMBOL		CODE SYMBOL
3-Way, 3-Position	3	4-Way, 3-Position, Free Flow	F4
3-Way, 3-Position, Free Flow	F3	4-Way, 4-Position, Float	K4
4-Way, 3-Position	4		

WORK PORT OPTIONS

The same work port options which are available for the Model V20P Directional Control Valve are also available for the Models V20C and V20LS in the "B" port location.

In the "A" port location, an optional anti-drift cartridge is also available. The anti-drift cartridge prevents any build-up of pressure at the work ports when the valve is in neutral position. Any leakage past the spool into the sensing cores is drained back to the tank through the anti-drift cartridge. When the work port is powered, pressure closes the anti-drift cartridge to eliminate any flow loss.

The anti-drift cartridge must be installed in the "A" port location only and one is required for each work section in which pressure build-up at the work port will be detrimental to the application.

The anti-drift cartridge replaces the standard load check plug. It is not available where a work port relief or anti-cavitation check is required in the "A" port location.

OPTION	ORDER CODE	AVAILABLE FOR:	
		"A" PORT	"B" PORT
Work Port Relief	RC,RP20	x	x
Combination Relief and Anti-Cavitation Check	CRA	x	x
Anti-Cavitation Check	AC	x	x
Load Check		—	x
Anti-Drift Cartridge	B	x	—

Pressure Compensated Flow Control

A pressure compensated flow control option is available for Models V20C and V20LS. This option is installed in the load check area of the valve section and is externally adjustable.

The flow control allows each valve section (both work ports) to operate at a predetermined maximum flow rate independent of pump discharge flow and pressure. Flow ranges of 1 to 5 GPM, 3 to 15 GPM, and 5 to 25 GPM are available.

This flow control option cannot be field installed. Special valve section machining is required.

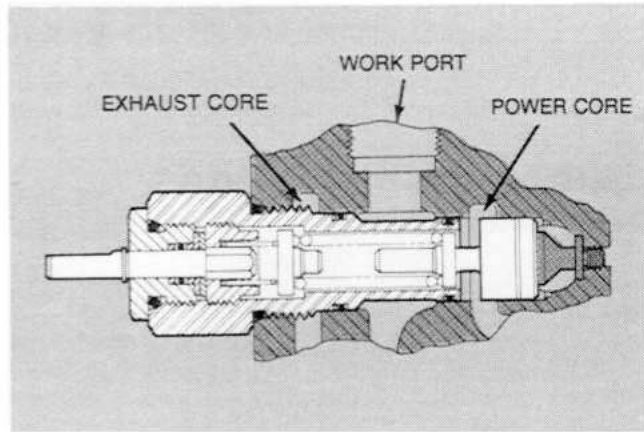

PRESSURE DROP

150 SUS oil at 100° F • Inlet port: SAE 12 • Work port: SAE 10

Inlet To Work Port

Typical pressure drop to any work port in a 4-spool valve

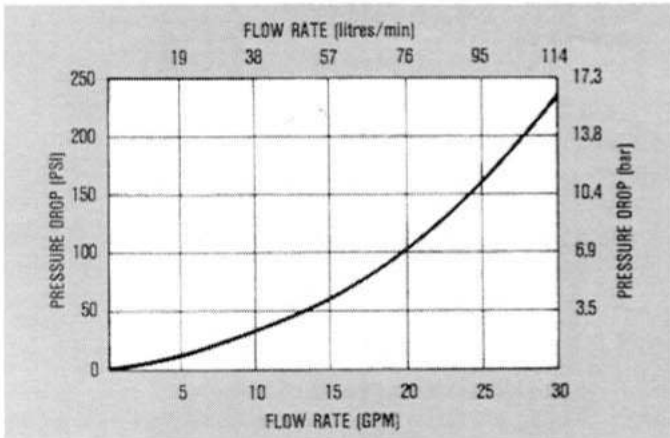

Work Port To Outlet

Typical pressure drop from any work port in a 4-spool valve

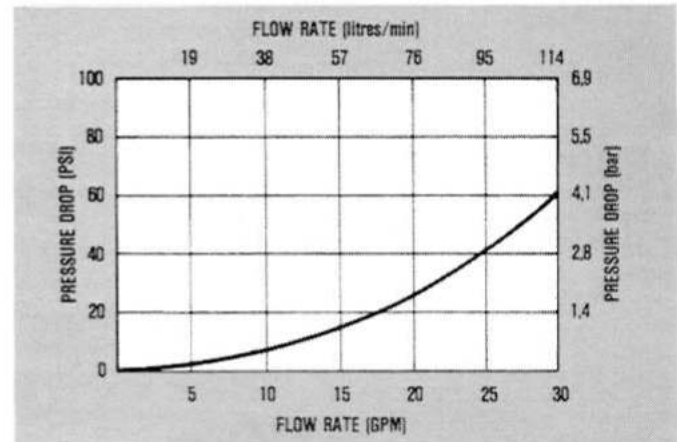

ORDERING INSTRUCTIONS

To assure delivery of the proper Directional Control Valve, Form 9005 must be completed. Additional ordering information needed for manufacture and assembly of Models V20C and V20LS work sections are:

1. To specify a valve with V20C closed center work sections or V20LS load sensing work sections, write in No. 8364 in the "Center Section Housing No." box for each work section required. Do not check the "Closed Center" box in right cover block.

- Under "Additional Features" write in V20C and check the box in each work section to specify a closed center valve.

OR

- Write in V20LS and check the box in each work section to specify a load sensing valve. Also specify Housing

No. 6770-LS in right cover block in order to include the SAE 4 pilot port.

2. If an anti-drift cartridge is required, write in under Cylinder Port "A", order symbol Anti-Drift Cartridge and check the box for each work section requiring this option.

NOTE: A V20 closed center valve can also be made from standard V20P, No. 8072, open center section by using a closed center plug in the right cover. To specify this type of closed center valve, write in Housing No. 8072 for center sections and check the closed center box in the right cover. (Anti-drift cartridge cannot be used in this valve.)

DIMENSIONS: Typical V20C and V20LS Assembly

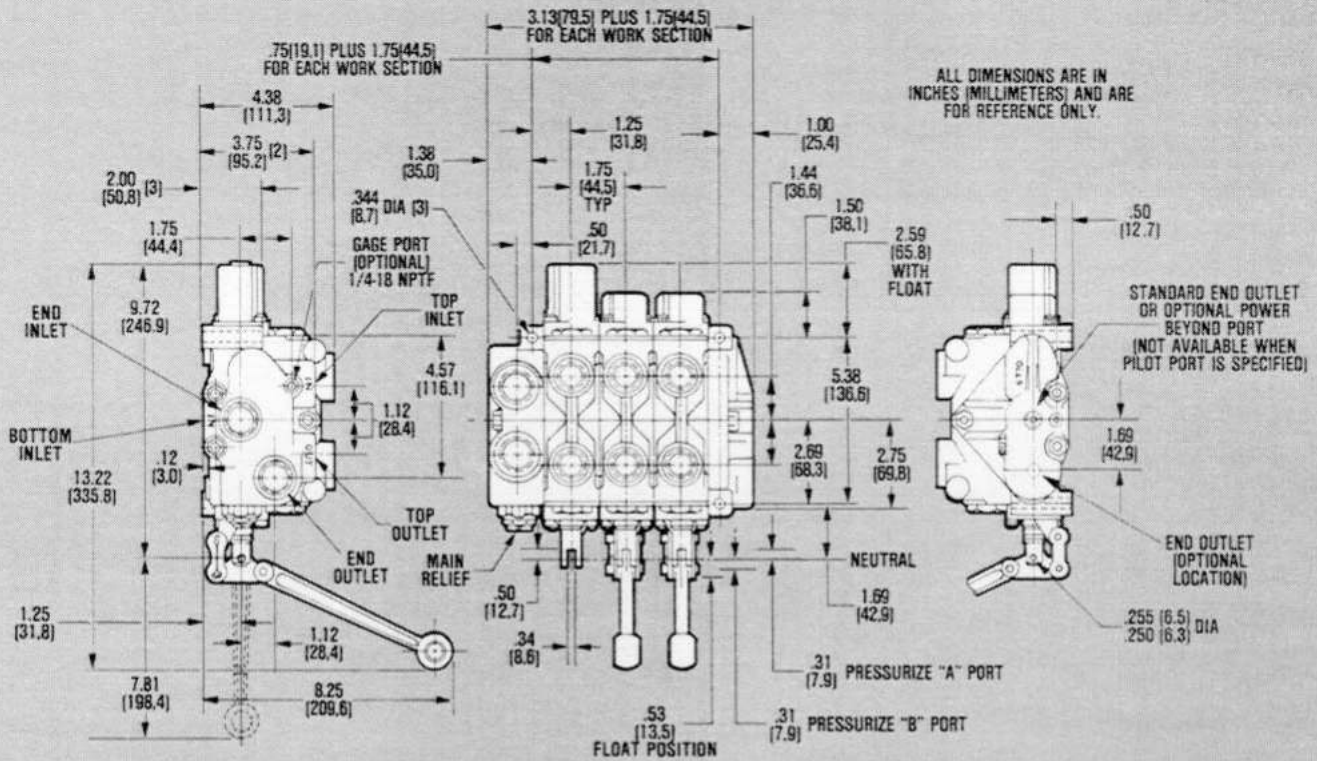

PORTING OPTIONS AVAILABLE

LOCATION	SAE STRAIGHT THREAD PORTS		BSP PIPE PORTS	GAGE PORT	PILOT PORT
	STANDARD	OPTIONAL			
No. 8398 LEFT INLET COVER* End, Top or Bottom Inlet Ports, End or Top Outlet Ports	SAE 12 (1-1/16" - 12 UN)	SAE 10 (7/8" - 14 UNF)	3/4" BSP	SAE 4 (7/16" - 20 UNF)	—
	SAE 10 (7/8" - 14 UNF)	SAE 8 (3/4" - 16 UNF)	1/2" BSP	—	—
No. 6770 RIGHT OUTLET COVER Standard or Optional End Outlet Ports	SAE 12 (1-1/16" - 12 UN)	SAE 10 (7/8" - 14 UNF)	3/4" BSP	—	SAE 4 (7/16" - 20 UNF)

*Top inlet and top outlet ports are cored. If not specified, they will be plugged.

NOTE: All ports in a casting must be the same. SAE and BSP ports cannot be intermixed.

ORDERING Condensed Table of Options for Complete Valve Assemblies

	Code Symbol	Inlet Cover (Left)	Work Sections					Mid-Inlet Conversion Section		Outlet Cover (Right)
			V20P, V20RP	V20T, V20RT	V20S	V20C	V20LS	Comb. Flow	Split Flow	
Circuits										
Open Center—Parallel	V20P		●					●	●	
Open Center—Parallel (Reduced Pressure Drop)	V20RP		●					●	●	
Open Center—Tandem	V20T			●				●	●	
Open Center—Tandem (Reduced Pressure Drop)	V20RT			●				●	●	
Open Center—Series	V20S				●			●	●	
Closed Center	V20C					●				
Load Sensing	V20LS						●			
Spool Variations										
3-Way, 3-Position	3		●	●	●	●	●			
3-Way, 3-Position, Free Flow	F3		●	●	●	●	●			
4-Way, 3-Position	4		●	●	●	●	●			
4-Way, 3-Position, Free Flow	F4		●	●	●	●	●			
4-Way, 4-Position, Float	K4		●	●	●	●	●			
4-Way, 3-Position, Pilot Operated Check (V20-LO)			●							
Spool Action Options										
Spring Return to Neutral (Standard)			●	●	●	●	●			
3-Position Detent	D		●	●	●	●	●			
No. 1889-001 Detent Stop			●	●	●	●	●			
4-Position Float	K4		●	●	●	●	●			
1-Position, Spool "IN" Detent	R		●	●	●	●	●			
1-Position, Spool "OUT" Detent	RO		●	●	●	●	●			
2-Position, Spool "IN" and "OUT" Detent	RIO		●	●	●	●	●			
Spring Extended Spool	A		●	●	●	●	●			
Manual	M		●	●	●	●	●			
Internal Pressure Detent Release	KO		●	●	●	●	●			
Electro-Mechanical Detent Release	E		●	●	●	●	●			
Solenoid Control			●	●	●	●	●			
Hydraulic Remote	HR, HRO		●	●	●	●	●			
Reliefs, Checks and Restrictors										
Main System Relief (Standard)	WH	●						●	●	
Main System Relief, with Lockwire & Lead Seal	WHNJ	●						●	●	
Main System Relief, Adjustable	WHA	●						●	●	
Main System Relief, Pilot-Operated, Adjustable	RP51A	●						●	●	
Main System Relief, Pilot-Operated, Non-Adjustable	RP51N	●						●	●	
Work Port Relief, Differential Poppet	RC		●	●	●	●	●			
Work Port Relief, Pilot-Operated, Adjustable	RP20A		●	●	●	●	●			
Work Port Relief, Pilot-Operated, Non-Adjustable	RP20N		●	●	●	●	●			
Combination Relief and Anti-Cavitation Check	CRA		●	●	●	●	●			
Anti-Cavitation Check	AC		●	●	●	●	●			
Pilot Operated Check (V20-LO)			●							
Load Check			●	●	●	●	●			
Restrictor			●	●	●	●	●			
Expansion Relief (V20-LO)			●							
No Relief	NR	●	●	●	●	●	●	●	●	
Handle and Handle End Options										
Complete Vertical Handle Assembly	CVHA		●	●	●	●	●			
Complete Horizontal Handle Assembly	CHHA		●	●	●	●	●			
Die Cast Handle Bracket			●	●	●	●	●			
Cast Iron Handle Bracket			●	●	●	●	●			
Standard Retainer Assembly			●	●	●	●	●			
Heavy Duty Retainer Assembly			●	●	●	●	●			
Spool Wiper			●	●	●	●	●			
Boot Assembly			●	●	●	●	●			
Less Handle Only	LHO		●	●	●	●	●			
Less Complete Handle Assembly	LCHA		●	●	●	●	●			
Hydraulic Remote with Handle Override	HRH		●	●	●	●	●			
Application Variations										
Open Center			●	●	●				●	
Closed Center	C		●*	●*		●	●		●	
Power Beyond	Y								●	
Conversion Plug	X								●	
Turnaround									●	

*V20P and V20T Valves can be converted to closed center systems by installing a plug in the outlet cover.

LEFT COVER		CENTER SECTIONS		#1	#2	#3	#4	#5	#6	RIGHT COVER	
HOUSING NO.		HOUSING NO.								HOUSING NO.	
PORT LOCATION	PORT SIZE	CIRCUIT	PARALLEL TANDEM SERIES							OUTLET	OUTLET PORT SIZE
IN											TURN AROUND
OUT		CHECK ONE FOR EA. SECT.	3-Way (Handle End Work Port is Plugged as Standard)							POWER BEYOND	POWER BEYOND PORT SIZE
			4-Way	4-Way Float (K)							CLOSED CENTER
GAGE PORT PLUGGED 1/4 NPT <input type="checkbox"/> SAE4 <input type="checkbox"/>										CONVERSION PLUG	
SYSTEM OPERATES AT:										MID-CONVERSION SECTION	
G.P.M. Max.	PSI Max.										
MAIN RELIEF INFORMATION		ADDITIONAL FEATURES								SECTION #	
Relief Model		Free-Flow (F)								HOUSING #	
Set at _____ PSI		3-Position Detent (D)								SECTION TYPE	
<input type="checkbox"/> Crack, or										RELIEF MODEL	
<input type="checkbox"/> Full Flow @ _____ GPM										RELIEF SETTING	
No Relief (NR) <input type="checkbox"/>										PORT SIZE	
HANDLE END INFORMATION		"A" & "B" WORK PORT SIZES									
A PORT END <input type="checkbox"/>		Work Port Relief [Specify Model]								D	
B PORT END <input type="checkbox"/>		Setting (PSI) at Full Flow or Crack								C	
Handle P/N _____ <input type="checkbox"/>		Anti-Cavitation Check								B	
Bracket P/N _____ <input type="checkbox"/>										A	
Spool Boots _____ <input type="checkbox"/>		CYL. PORT "A"								LET	DATE
		Work Port Relief [Specify Model]								ORIG. BY:	DATE:
		Setting (PSI) at Full Flow or Crack								ERO	Engr. Appr.
		Anti-Cavitation Check								APPLICATION	
FUNCTION OF SECTION										CUSTOMER PART NO.	
REMARKS:										CUSTOMER	
										ORDER DESIGN	
										MODEL NO.	B/M

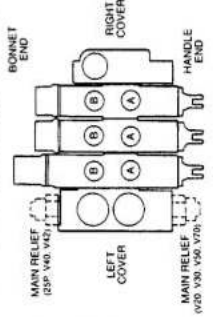



Parker Hannifin Corporation
Hydraulic Valve Division
520 Ternes Avenue
Elyria, Ohio, USA 44035
Tel: (440) 366-5200
Fax: (440) 366-5253
www.parker.com/hydraulicvalve

Bulletin HY14-2705-B1/US,
5C, 1/04, PHD