

OPERATION / MAINTENANCE MANUAL

MODEL 400 VIBRATORY HAMMER WITH
MODEL 800 POWER UNIT

7032 So. 196th - Kent, WA. 98032 - (206) 872-0141 / Fax (206) 872-8710

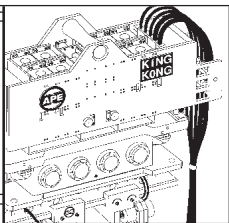

OPERATION AND MAINTENANCE MANUAL

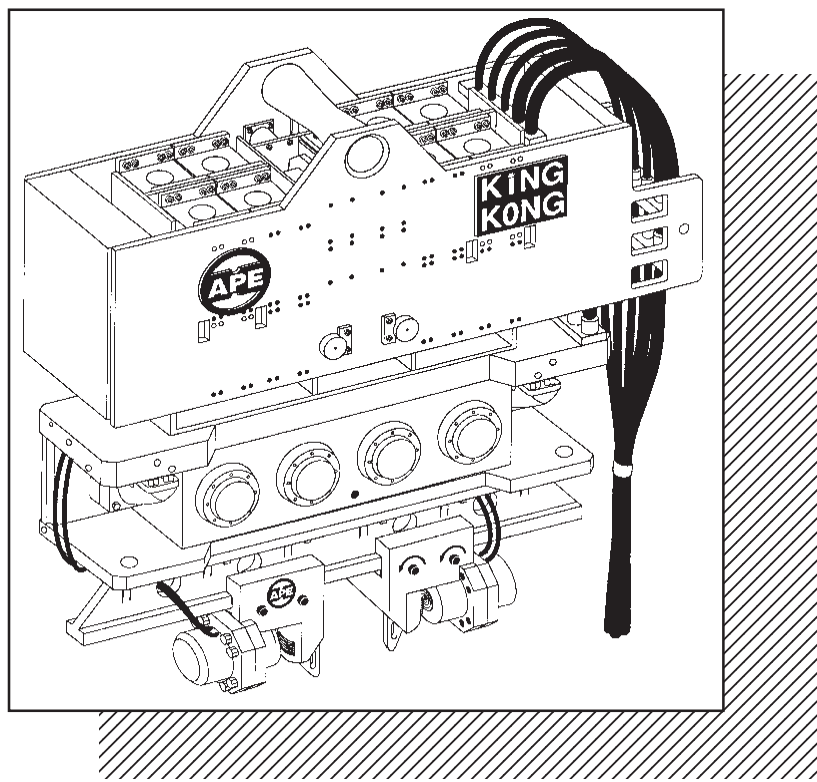

SERIAL NUMBER:

**MODEL 400 VIBRO
WITH MODEL 800 POWER UNIT**



OPERATION / MAINTENANCE MANUAL

MODEL 400 VIBRATORY HAMMER WITH
MODEL 800 POWER UNIT

7032 So. 196th - Kent, WA. 98032 - (206) 872-0141 / Fax (206) 872-8710

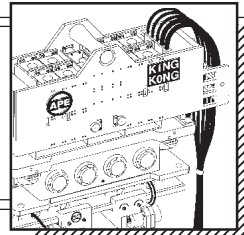

Revision Record

Change Number	Page Number	Date	Revision Description
01	--	1/8/94	Revised Troubleshooting, O-Rings, Bolts & Hoses.
			added Power Unit & Engine Information. Added 2-8
02	--	5/25/94	Added new pendant & misc. updates.



OPERATION / MAINTENANCE MANUAL

MODEL 400 VIBRATORY HAMMER WITH
MODEL 800 POWER UNIT

7032 So. 196th - Kent, WA. 98032 - (206) 872-0141 / Fax (206) 872-8710

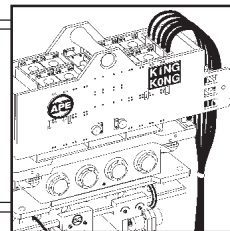

Preface

General

This manual covers the **Model 400 Vibratory Hammer and Model 800 Power Unit**. The data provided in this manual gives the necessary information to operate and maintain APE equipment. The listed procedures are to be performed by qualified personnel who have an understanding of the equipment and who follow all safety precautions.

Guide to Using the Manual

1. Refer to the Table of Contents for the page location of applicable sections.
2. All weights and measurements in this manual are in both English and Metric units.
3. The manual will be revised as necessary to reflect current information.

Abbreviations

The following are abbreviations used within this manual.

- lbs.** = Pounds
- psi.** = Pounds per Square Inch
- hp.** = Horse Power
- gpm.** = Gallons Per Minute
- rpm.** = Revolutions Per Minute
- eng.** = Engine
- cyl.** = Cylinder
- mm.** = Millimeter
- mtg.** = Mounting
- S/N** = Serial Number
- sol.** = Solinoid

Serial Number Locations

1. **VIBRATOR:** Above and in between the eccentric covers on both sides of the machine.
2. **POWER UNIT:** On back of the hydraulic tank above the APE logo.

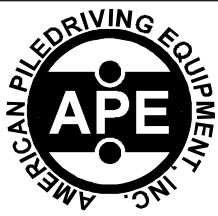

OPERATION / MAINTENANCE MANUAL

MODEL 400 VIBRATORY HAMMER WITH
MODEL 800 POWER UNIT

7032 So. 196th - Kent, WA. 98032 - (206) 872-0141 / Fax (206) 872-8710

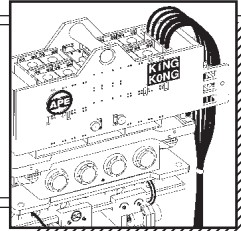

Table of Contents

	Page
Revision Record	i
Preface	ii
Table of Contents	iii
Safety Precautions	v
Illustration List	vi
Table List	vi
Warranty	vii
I. GENERAL INFORMATION	1-1
I-1. Machine Features	1-1
I-2. Machine Specifications	1-2
A. Model 400 Vibro	1-2
B. Model 800 Power Unit	1-2
I-3. General Description of Model 400 Vibro	1-3
A. Suppressor Housing	1-4
B. The Vibrator Gearbox	1-5
C. Clamp Attachment	1-6
D. Optional Attachments	1-7
I-4. General Description of Model 800 Power Unit	1-8
II. MAJOR COMPONENT DEFINITION	2-1
II-1. Component Identification	2-1
II-2. Hose Identification	2-3
II-3. Caisson Clamp Identification	2-4
II-4. Model 800 Power Unit Skid Identification	2-5
II-5. Quick Disconnect Couplings	2-6
II-6. Tool Set Identification	2-7
II-7. Caisson Clamp Wedge Actuator	2-8
III. LOADING AND UNLOADING	3-1
III-1. Model 400 Vibratory Hammer	3-1
III-2. Model 800 Power Unit	3-1
III-3. What to do if damaged during shipment	3-1
IV. PREPARATION AND OPERATION	4-1
IV-1. Rigging of Vibratory Hammer	4-1
IV-2. Installing the Clamp Attachment	4-1
IV-3. Plumbing the Vibro Hoses to the Power Unit	4-2
IV-4. Filling Vibrator Pressure Hose	4-3
IV-5. Bleeding Clamp Attachment Hydraulic Hoses	4-3
IV-6. Precautions and Rules for Operation	4-4
IV-7. Relief Valve Settings Prior to Operation - Model 800	4-5
IV-8. Shut-down Procedures	4-5
IV-9. Operation of the Remote Control Pendant	4-6
IV-10. Normal Steps to Operate Vibrator	4-6
V. MAINTENANCE	5-1
V-1. Daily Maintenance Required Prior to Operation	5-1
V-2. Checklist After Power Unit Engine Has Started	5-1
V-3. Maintenance and Adjustments: (75 Hours)	5-2
V-4. Maintenance and Adjustments: (Eccentric Bearings)	5-2
V-5. Maintenance and Adjustments in Severe Conditions	5-2
V-6. Lubrication	5-2
A. Vibratory Gearbox	5-2
B. Clamp Attachment	5-2



OPERATION / MAINTENANCE MANUAL

MODEL 400 VIBRATORY HAMMER WITH MODEL 800 POWER UNIT

7032 So. 196th - Kent, WA. 98032 - (206) 872-0141 / Fax (206) 872-8710

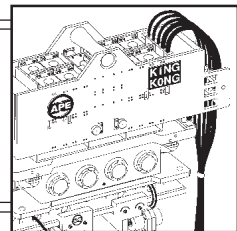

Table of Contents (Continued...)

V. MAINTENANCE (Continued...)

V-7. Power Unit	5-3
A. Power Unit Filters, Fluid Types and Capacities	5-3
B. Hydraulic Fluid	5-4
C. Draining and Filling Hydraulic Fluid Tank	5-4
D. Cleaning Hydraulic Tank Suction Filter	5-4
E. Changing Hydraulic Return Filter Element	5-5
F. Steps to Remove Filter Element	5-5
V-8. Hydraulic Motor - Installation and Start-Up	5-6
V-9. Hydraulic Motor Coupling Assembly	5-7

VI. TROUBLESHOOTING: Model 400 Vibro

6-1

VII. MODEL 800 POWER UNIT

7-1

VII-1. Hydraulic Circuitry	7-1
A. Drive Circuit	7-1
B. Clamp Circuit	7-1
C. Oil Cooler	7-2
D. Manual Pump	7-2
E. Hydraulic Oil Temperature	7-2
F. Hydraulic Components	7-2
G. Hydraulic Schematic	7-3
VII-2. Electrical Circuitry	7-4
A. Diesel Engine	7-4
B. Controls: Understanding How They Work	7-4
C. Preparing The Electrical System For Start-Up	7-7
D. Engine Safety Shut-Down Button Switch	7-7
E. Engine Safety Shut-Down (Three Causes Of Engine Shut-Down)	7-8
F. Electrical Schematic	7-9
VII-3. Remote Control Pendant	7-10
A. Remote Pendant Wiring Diagram	7-11
VII-4. Troubleshooting: Power Unit Electrical	7-12
A. Engine Oil Pressure Switch	7-12
B. Water Temperature Switch	7-12
C. Hydraulic Oil Level Switch	7-12
D. Oil Pressure Sending Unit	7-13

APPENDIX A - CAT 3412 Twin Turbo 800 HP Engine

A-1. ENGINE OPERATION INSTRUCTIONS.	A-1
A. Pre-Start Inspection and Procedures.	A-1
B. Starting The Engine	A-2
C. Engine Operation	A-3
D. Determining Cause of Shutdown	A-7
A-2. MAINTENANCE RECOMMENDATIONS	A-9
A. Lubrication Specifications	A-10
B. Fuel Specifications	A-11
C. Coolant Specifications	A-11
D. Lubrication and Maintenance	A-12
E. Electrical System	A-13
A-3. ENGINE TROUBLESHOOTING	A-14



OPERATION / MAINTENANCE MANUAL

MODEL 400 VIBRATORY HAMMER WITH
MODEL 800 POWER UNIT

7032 So. 196th - Kent, WA. 98032 - (206) 872-0141 / Fax (206) 872-8710

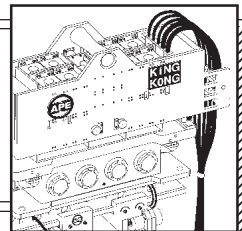

Safety Precautions

(This list of precautions must be followed at all times to ensure personal & equipment safety.)

1. Read this manual from beginning to end before operating or working on this machine.
2. When operating in a closed area, pipe exhaust fumes outside. (**WARNING:** Breathing exhaust fumes can cause serious injury and even death.)
3. When servicing batteries, avoid any type of spark or open flame. Batteries generate explosive gases during charging. There must be proper ventilation when charging batteries.
4. Never Adjust or repair the unit while it is in operation.
5. Make sure the Control Pendant is in the "OFF" position before starting the unit.
6. Remove all tools and electrical cords before starting the unit.
7. Keep oily rags away from the exhaust system.
8. Never store flammable liquids near the engine.
9. Never stand under vibro at any time and keep your eyes on the vibro when it is in operation. Keep a look out for loose bolts or leaking hydraulic lines.
10. Avoid pulling on hose quick dis-connect fittings. Move power unit closer to work if hoses cannot reach. Do not use hoses as a tow line to tug the power unit! If a hose fails at the hydraulic couplers then it is a result of "hose tugging by the pile crew".
11. Avoid kinks in the hoses. Kinks will cut the hose safety factor by 50 percent.
12. Always wear eye and ear protection.
13. Avoid standing downwind of vibrating piles. Dirt and other matter may become airborne and fall into the unprotected eye.
14. Always wear a hardhat, gloves, and safety shoes.
15. Always attach safety line to pile when extracting or hoisting into position.
16. (**WARNING**) Never clamp vibro to pile and dis-connect from crane line. Lay vibro down on ground when not in use.
17. Do not truck power unit with quick disconnect caps and plugs screwed on to fittings unless the caps and plugs have wire rope safety lines attached. Store in storage box under control panel.



OPERATION / MAINTENANCE MANUAL

MODEL 400 VIBRATORY HAMMER WITH
MODEL 800 POWER UNIT

7032 So. 196th - Kent, WA. 98032 - (206) 872-0141 / Fax (206) 872-8710

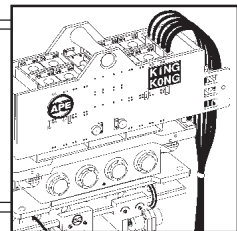

Illustration List

Figure	Title	Page
1-A.	Machine Features	1-1
1-B.	General Description of Model 400 Vibro	1-3
1-C.	General Description of Suppressor Housing	1-4
1-D.	General Description of Vibratory Gearbox	1-5
1-E.	General Description of Clamp Attachment	1-6
1-F.	Clamp Attachment Hole Configuration	1-6
1-G.	Optional Attachments	1-7
1-H.	General Description of Model 800 Power Unit	1-8
2-A.	Component Identification	2-1
2-B.	Hose Bundle Identification	2-3
2-C.	Caisson Clamp Identification	2-4
2-D.	Model 800 Power Unit Skid Identification	2-5
2-E.	Quick Disconnect Couplings	2-6
2-F.	Tool Set Identification	2-7
2-G.	Caisson Clamp Wedge Actuator	2-8
4-A.	Power Unit Coupler Layout	4-2
4-B.	Bleeding Clamp Attachment	4-3
5-A.	Hydraulic Motor - Installation and Start-Up	5-6
5-B.	Hydraulic Motor Coupling Assembly	5-7
7-A.	Power Unit Hydraulic Schematic	7-3
7-B.	Power Unit Electrical Schematic	7-9
7-C.	Remote Control Pendant	7-10
7-D.	Remote Pendant Wiring Diagram	7-11

Table List

Table	Title	Page
1-A.	Machine Specifications - Model 400 Vibro	1-2
1-B.	Machine Specifications - Model 800 Power Unit	1-2
2-A.	Component Identification	2-2
2-B.	Hose Identification	2-3
2-C.	Caisson Clamp Identification	2-4
2-D.	Model 800 Power Unit Skid Identification	2-5
2-E.	Tool Set Identification	2-7
2-F.	Caisson Clamp Wedge Actuator	2-8
5-A.	Power Unit - Filters, Fluid Types and Capacities	5-3
6-A.	Trouble-Shooting	6-1
7-A.	Hydraulic Components	7-2



OPERATION / MAINTENANCE MANUAL

**MODEL 400 VIBRATORY HAMMER WITH
MODEL 800 POWER UNIT**

7032 So. 196th - Kent, WA. 98032 - (206) 872-0141 / Fax (206) 872-8710

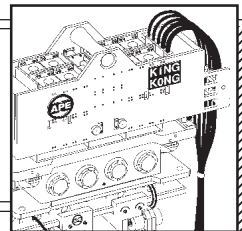

Warranty

American Piledriving Equipment, Inc. STANDARD WARRANTY

American Piledriving Equipment, Inc. (APE) warrants new products sold by it to be free from defects in material or workmanship for a period of one year after the date of delivery to the first user and subject to the following conditions:

APE's obligation and liability under this WARRANTY is expressly limited to repairing or replacing at APE's option, any parts which appear to APE upon inspection to have been defective in material or workmanship. Such parts shall be provided at no cost to the user, at the business establishment of APE or the authorized APE distributor of the product during regular working hours. **This WARRANTY, shall not apply to component parts or accessories of products not manufactured by APE** and which carry the warranty of the manufacturer thereof, or to normal maintenance (such as engine tune-up) or normal maintenance parts (such as filters).

Replacement or repair parts installed in the product covered by this WARRANTY are warranted only for the remainder of the warranty as if such parts were original components of said product. AMERICAN PILEDIVING EQUIPMENT, INC. makes no other warranty, expressed or implied and makes no warranty of merchantability of fitness for any particular purpose.

APE's obligation under this WARRANTY shall not include any transportation charges, costs of installation, duty, taxes or any other charges whatsoever, or any liability for direct, indirect, incidental or consequential damage or delay. If requested by APE, products or parts for which a warranty claim is made are to be returned transportation prepaid to APE. Any improper use, including operation after discovery of defective or worn parts, operation beyond rated capacity, substitution of any parts whatsoever, or parts not approved by APE or any alteration or repair by others in such manner as in APE's judgment affects the product materially and adversely, shall void this warranty.

NO EMPLOYEE OR REPRESENTATIVE IS AUTHORIZED TO CHANGE THIS WARRANTY IN ANY WAY OR GRANT ANY OTHER WARRANTY UNLESS SUCH CHANGE IS MADE IN WRITING AND SIGNED BY AN OFFICER OF APE, INC.

**ANY TYPE OF WELDING ON EQUIPMENT
WILL VOID THE WARRANTY**

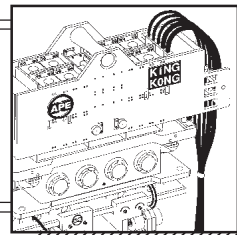

I. GENERAL INFORMATION

I-1. Machine Features. - Model 400 Vibratory Hammer.

Patented breakthrough multi-stage suppressor housing allows variable suppression levels which change to match variable line pull.

The Model 400 out performs other vibros in its class. It is lighter and allows more pull and reach.

The heavy duty lifting pin allows easy rigging of the vibro and two safety lift pins ensure maximum safety.

Up to 200 Tons of line pull! More pulling ability than other comparable vibros.

Shorter overall height and a lower center of gravity.

One piece eccentric/gear design eliminates bolts, keyways, splines and pins.

Four eccentrics filled with "heavy metals" produce more amplitude with less parts.

Giant spherical bearings are five times larger than those found on other machines.

Heavy clamp cylinders need no guards and all hoses are tucked out of harms way. The one piece design eliminates rear seals, tie rods & nuts.

Gear box drilled to accept attachments manufactured by APE and by other manufacturers.

High speed gear train allows the vibratory Hammer to operate off many different power units.

Gearbox incorporates a machined O-ring groove to seal the top plate with no leaky gaskets.

Rifle bored top plate eliminates more unwanted hoses that can cause serious downtime.

Hydraulic motors are recessed which eliminates the need for bolted on guards. Less parts - less problems. Vertical motor mounting is approved by Volvo.

Computer designed gearbox is perfectly balanced with a very low center of gravity. Release crane line without bending piles.

The 400 vibro can be shipped fully assembled on one truck.

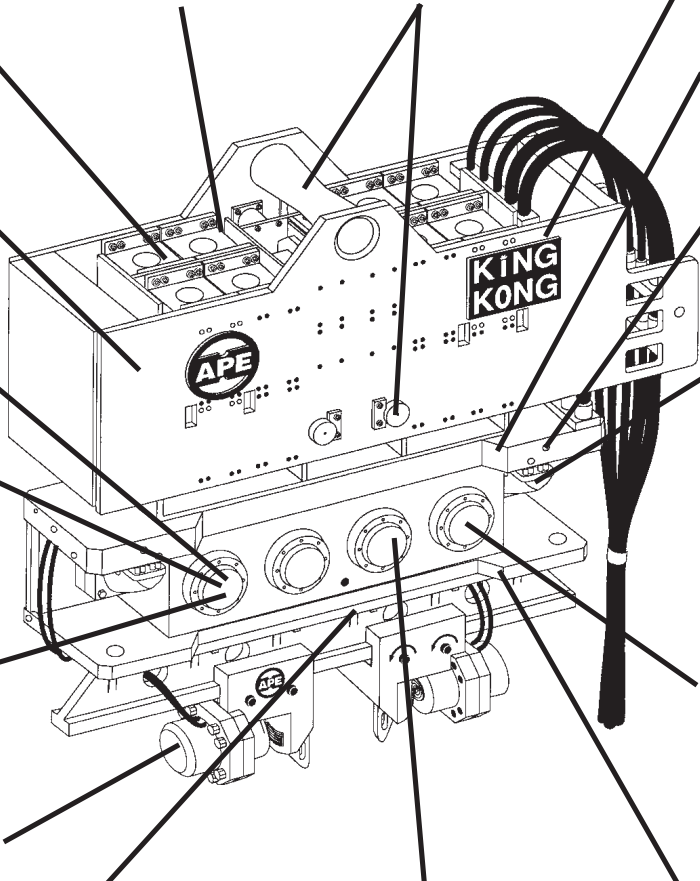

Figure 1-A. Machine Features



OPERATION / MAINTENANCE MANUAL

MODEL 400 VIBRATORY HAMMER WITH MODEL 800 POWER UNIT

7032 So. 196th - Kent, WA. 98032 - (206) 872-0141 / Fax (206) 872-8710

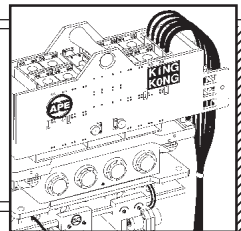

I. GENERAL INFORMATION (Continued...)

APE "KING KONG" MODEL 400 VIBRATORY PILE DRIVER/EXTRACTOR

I-2. Machine Specifications.

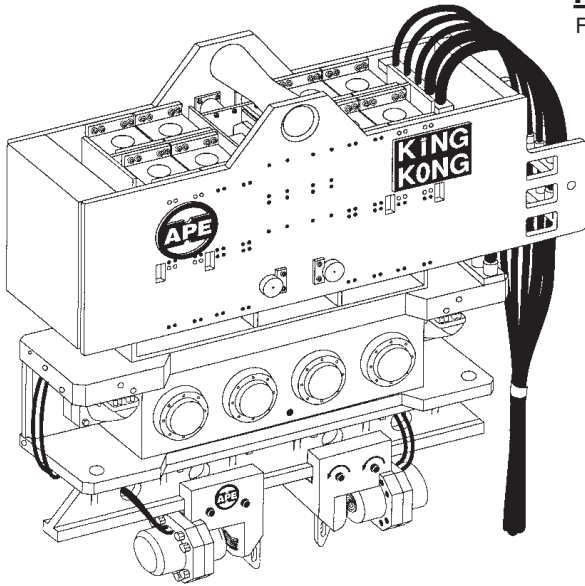

I-2A. Model 400 Vibratory Hammer - (Table 1-A.)

For driving and extracting heavy caissons, sheets or plates in clay soil conditions.

Eccentric Moment	Consult Factory
Drive Force	400 Tons (3,559 kN)
Frequency (cpm)	0 to 1500
Amplitude	1 1/8" (28.5 mm)
Pile Clamp Force	250 Tons (2,224 kN)
Line Pull for Extraction	200 Tons (1,780 kN)
Hydraulic Hose Length	200 feet (61 meters)
Suspended Weight*	34,000 lbs (15,445 Kg)
Length	120 inches (660 mm)
Width	26 inches (660 mm)
Height	70 inches (1,778 mm)
Height with Clamp	96 inches (2,438 mm)

APE engineers can adjust flows and pressures to job site requirements.
* Suspended weight includes all hoses.

I-2B. Model 800 Hydraulic Power Unit - (Table 1-B.)

Hydraulic source for super large vibros and high torque drills

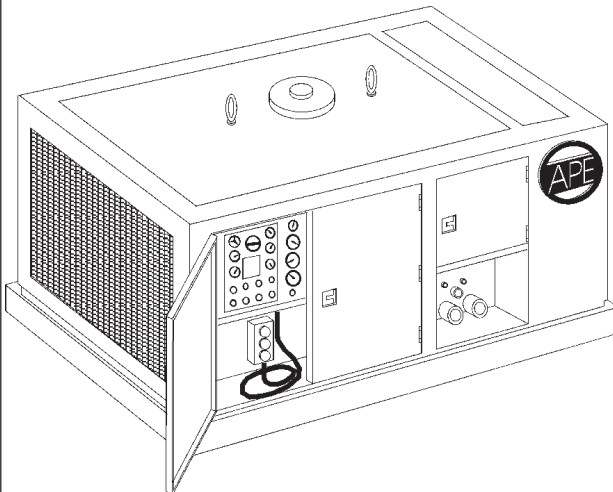

Engine	CAT 3412 Twin Turbo 800 HP
Maximum Power	800 HP (597 kW)
Operating Speed	2000 rpm.
Maximum Drive Pressure	6000 psi. (414 bar)
Maximum hyd. flow: Forward:	250 gpm. (946 lpm)
Maximum hyd. flow: Reverse:*	250 gpm. (946 lpm)
Clamp Pressure	6000 psi. (414 bar)
Clamp Pump Flow @ 2200 rpm.	10 gpm. (38 lpm)
Weight	24,000 lbs. (10,909 kg)
Length	174 inches (4,420 mm)
Width	82 inches (2,083 mm)
Height	96 inches (2,438 mm)

* Operates APE Model 75 Drill with 75,000 ft. lbs. of torque @ 50 rpm.

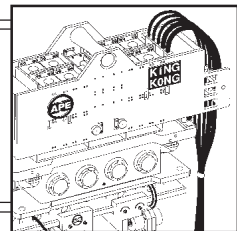

I. GENERAL INFORMATION (Continued...)

I-3. General Description of Model 400 Vibro.

The **APE Model 400** is a variable frequency vibratory pile driver/extractor designed for driving and extracting extremely large caissons, heavy plates, sheet piles, closed-ended pipe piles and concrete piles in difficult soil conditions including clay. The 400 can also be used for soil compaction and pre-boring by displacement method where contaminated soils cannot be removed.

The Model 400 operates in a frequency range of 0 to 1500 cycles per minute depending on the hydraulic flow and on the hydraulic motors fitted to the gear train.

The three major parts to the Model 400 are as follows:

- A.) The Suppressor housing.
- B.) The Gearbox.
- C.) The Clamping Attachment.

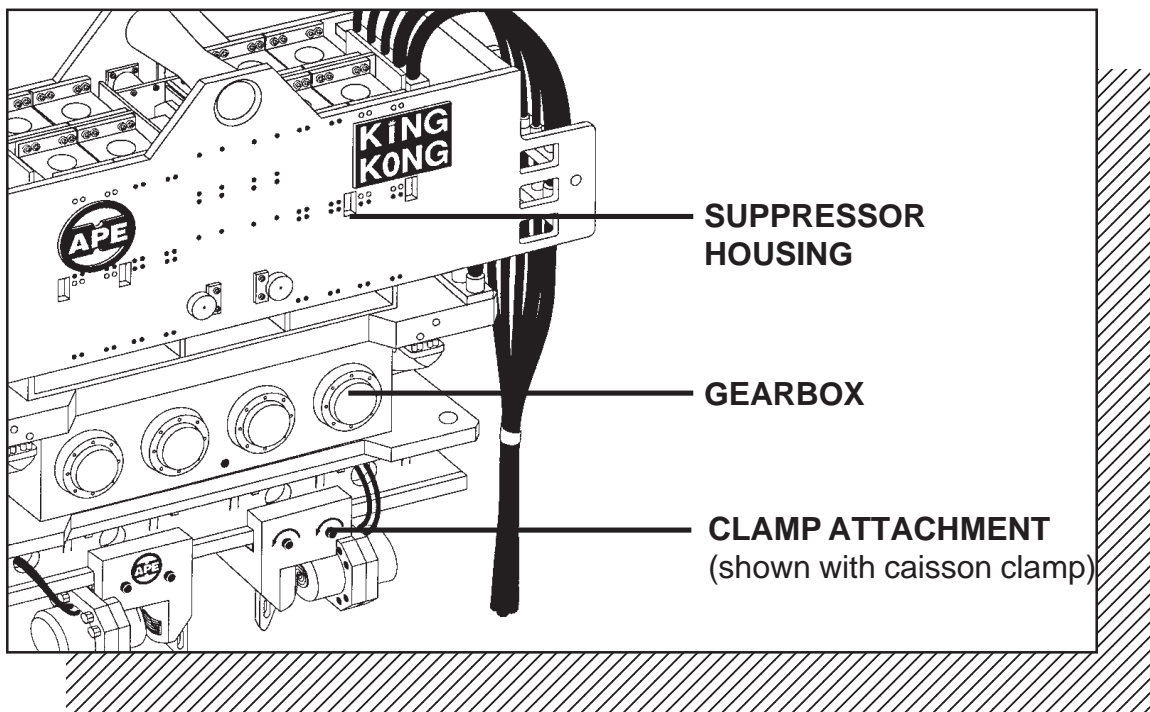
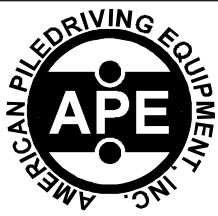

Figure 1-B. General Description of Model 400 Vibro.



OPERATION / MAINTENANCE MANUAL

MODEL 400 VIBRATORY HAMMER WITH
MODEL 800 POWER UNIT

7032 So. 196th - Kent, WA. 98032 - (206) 872-0141 / Fax (206) 872-8710

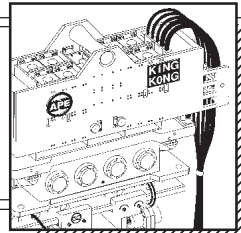

I. GENERAL INFORMATION (Continued...)

I-3A. The Suppressor Housing.

The suppressor housing of the **Model 400 APE Vibrator** is a patented multi-stage system consisting of up to sixteen large rubber elastomers and eight small elastomers. The large rubber elastomers (technically called the first stage) are used during all driving operations and light to medium extraction. The second stage is made up of eight small high capacity elastomers. During the first stage, two large safety pins travel up with the outer housing as the line pull is increased. The safety pins are then engaged by the lifting bracket which activates the second stage. **(WARNING! Hard pulling for long periods of time will heat and damage the large elastomers. The heat generated from constant heavy line pull will destroy the chemical bond between the rubber and mounting plate which will cause the large elastomer to fail.)** When engaged in hard extracting, break every 15 minutes to allow elastomers to cool.

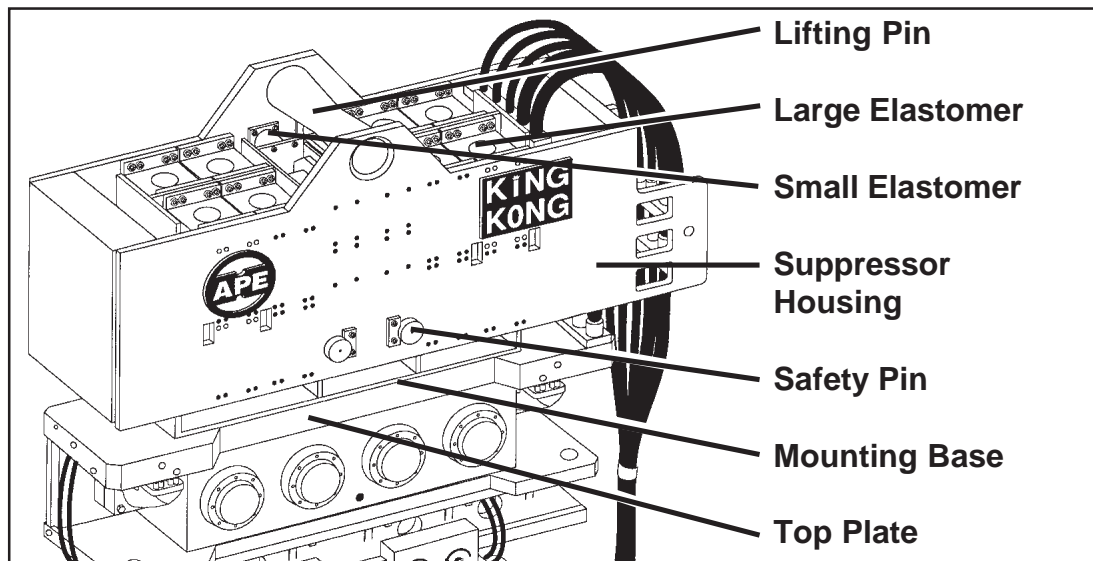
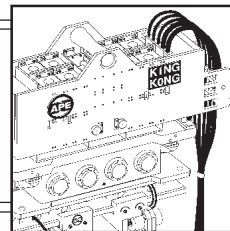

Figure 1-C. General Description of Suppressor Housing.



I. GENERAL INFORMATION (Continued...)

I-3B. The Vibrator Gearbox.

The vibrator gearbox contains four high amplitude eccentric weights cast in one piece with the gear. This design is unique to the industry and was developed by the engineers of APE to solve a number of problems associated with other types of vibrator machines. Both the eccentric and the drive gears have been helically cut to provide high speed operation with reduced noise and wear. Vibration is caused by the vertical movement created when the eccentrics are rotated. The eccentric and drive gears are all driven in line by two Volvo motors tucked in on the outboard side of the gearbox. The motors are recessed for maximum protection. The eccentrics rotate on four shafts housed by eight giant spherical bearings. The gears and bearings receive lubrication as a result of the fluid splashing inside the gearbox when the gears are rotated. The oil level is quickly determined by looking at the site gauge. The Model 400 can be operated under water to a depth of 30 feet without modifications. (Consult factory for depths below 30 feet.)

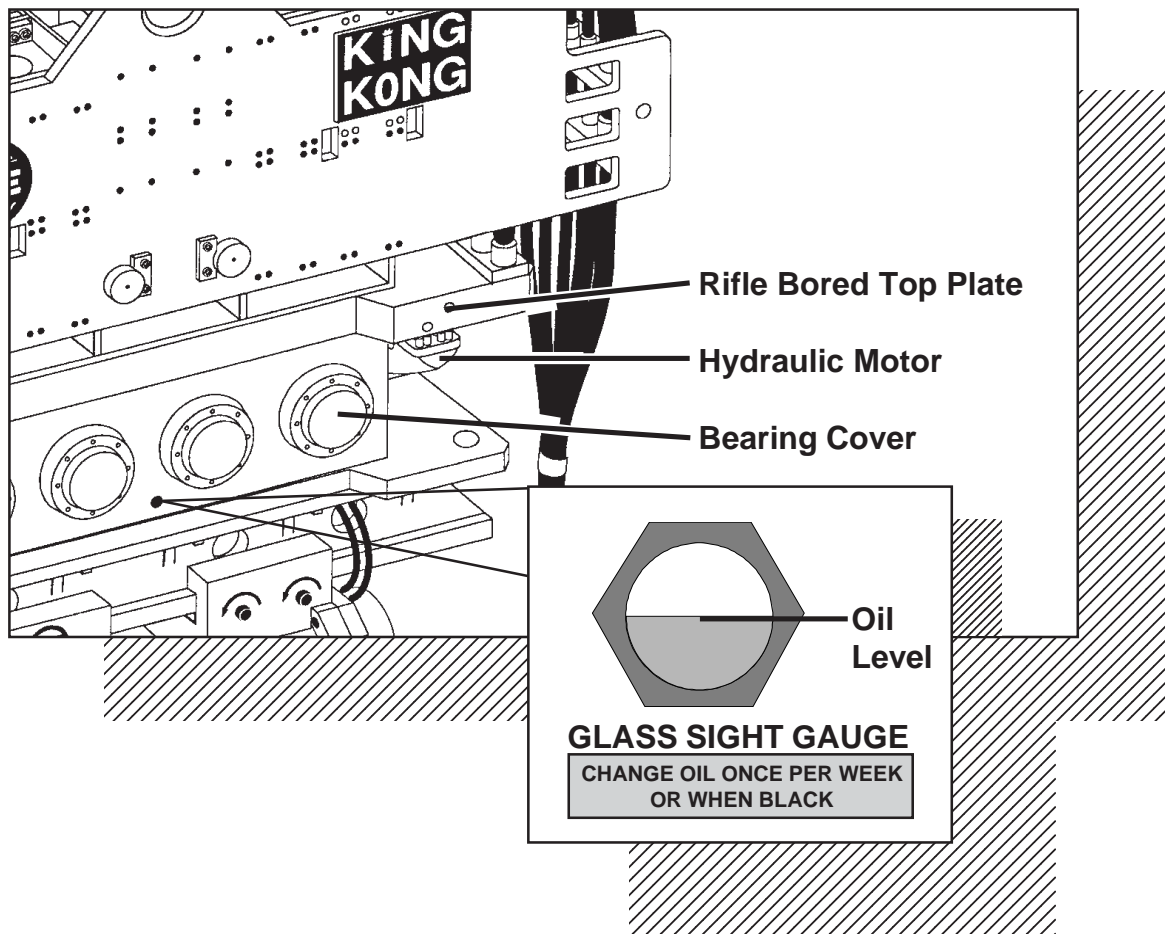
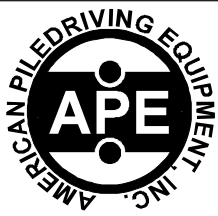

Figure 1-D. General Description of Vibrator Gearbox.



OPERATION / MAINTENANCE MANUAL

MODEL 400 VIBRATORY HAMMER WITH
MODEL 800 POWER UNIT

7032 So. 196th - Kent, WA. 98032 - (206) 872-0141 / Fax (206) 872-8710

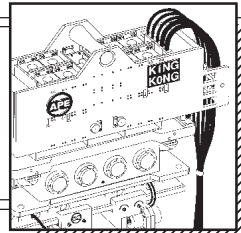

I. GENERAL INFORMATION (Continued...)

I-3C. The Clamp Attachment.

The APE Model 400 comes with a **Caisson Beam and Caisson Clamps**. The clamps contain two gripping jaws. One is "fixed" and one is "moveable." A large hydraulic cylinder operates the moveable jaw with up to 250 tons of clamping force depending on clamp pump relief pressure. The jaws open and close by turning a switch on the remote control pendant or may be operated by turning the switch at the main control panel mounted behind one of the doors on the power unit. The valve can be manually operated with a screwdriver if all electrical fails. **The APE Caisson Clamp** can be used for driving and extracting caissons from 16 inches to 11feet. The one piece cast beam will not bend or break and was designed to be compatible with all types of vibros. The heavy duty design of the clamp cylinders eliminates the need for cylinder guards. The clamps are held in place on the beam with a simple wedge-lock design. (Clamps can be fitted with hydraulically activated wedges for faster adjustments when driving more than one size caisson. Please call the factory for more information on clamp attachments for special pile types.)

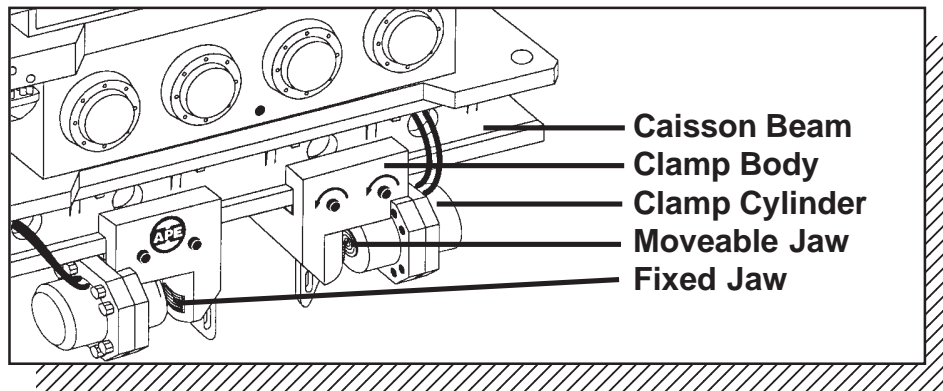

Figure 1-E. General Description of Clamp Attachment.

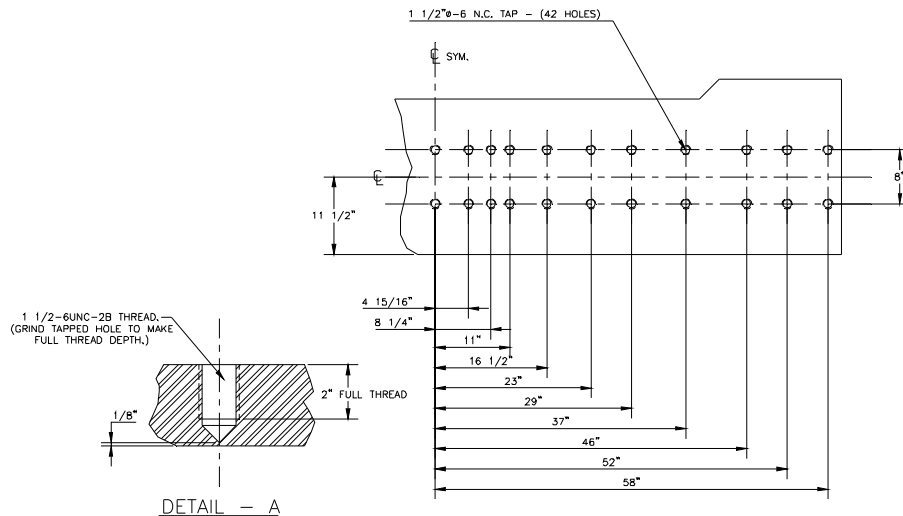

Figure 1-F. Clamp Attachment Hole Configuration



OPERATION / MAINTENANCE MANUAL

MODEL 400 VIBRATORY HAMMER WITH
MODEL 800 POWER UNIT

7032 So. 196th - Kent, WA. 98032 - (206) 872-0141 / Fax (206) 872-8710

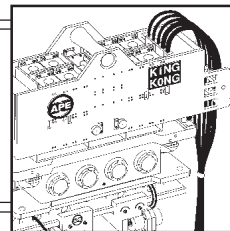

I. GENERAL INFORMATION (Continued...)

I-3D. Optional Attachments.

The following are some of the optional attachments for the Model 400 Vibratory hammer. (Contact APE or your local APE distributor for more information about these and other available equipment.)

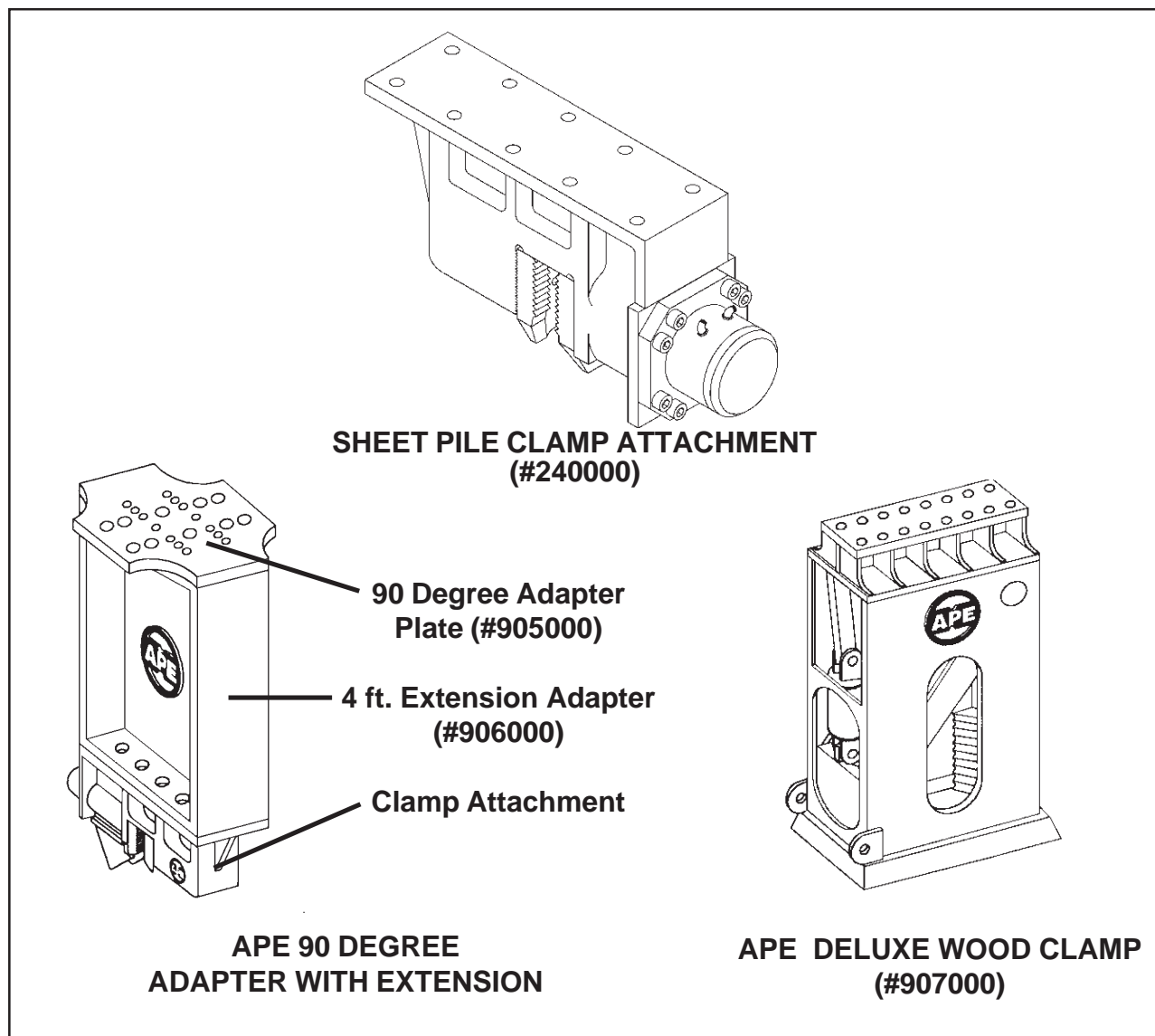

Figure 1-G. Optional Attachments



OPERATION / MAINTENANCE MANUAL

MODEL 400 VIBRATORY HAMMER WITH MODEL 800 POWER UNIT

7032 So. 196th - Kent, WA. 98032 - (206) 872-0141 / Fax (206) 872-8710

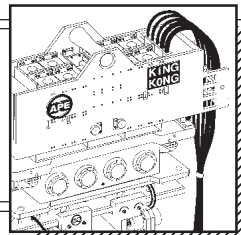

I. GENERAL INFORMATION (Continued...)

I-4. General Description of Model 800 Power Unit

The Model 400 vibrator runs off the APE 800 power unit. The APE 800 has a CAT 3412 Twin Turbo 800 horsepower engine. The engine is mounted to a tubular frame that also serves as a diesel fuel tank. A sheet metal and tube frame covers the engine and is equipped with locking doors for protection from the environment. A control panel is located behind one of the doors and comes complete with a 50 foot control pendant. There are two hydraulic tanks on the power unit. One is the main tank and the other is a storage tank for extra oil in case the main tank becomes depleted. A hydraulic tank supplies oil to four pumps. Three pumps feed the two vibrator motors. A small pump feeds the clamp attachment. The Vibrator is connected to the power unit via five hydraulic hoses. The two large 2" hoses are the pressure and return lines for the vibrator motors. The two smaller 3/8" hoses are for the clamp system and the one middle sized 1 1/4" hose is for the vibrator motor case drain line. The hoses are attached to the power unit by connecting the "quick dis-connect fittings" on the end of the hoses leading from the vibrator. The fittings go on only one way so there is no chance of hooking up the hoses improperly.

WARNING: Clean with ether or a clean rag before installing quick disconnects. Make sure you seat the quick disconnect fittings all the way tight. Failure to tighten the quick disconnects will stop the flow of oil and will prevent the vibro from operating. Failure to tighten the clamp fittings completely tight will cause the jaws to either not open or not close. If this happens you may have to crack the fitting and bleed off the pressure to release the quick dis-connects.

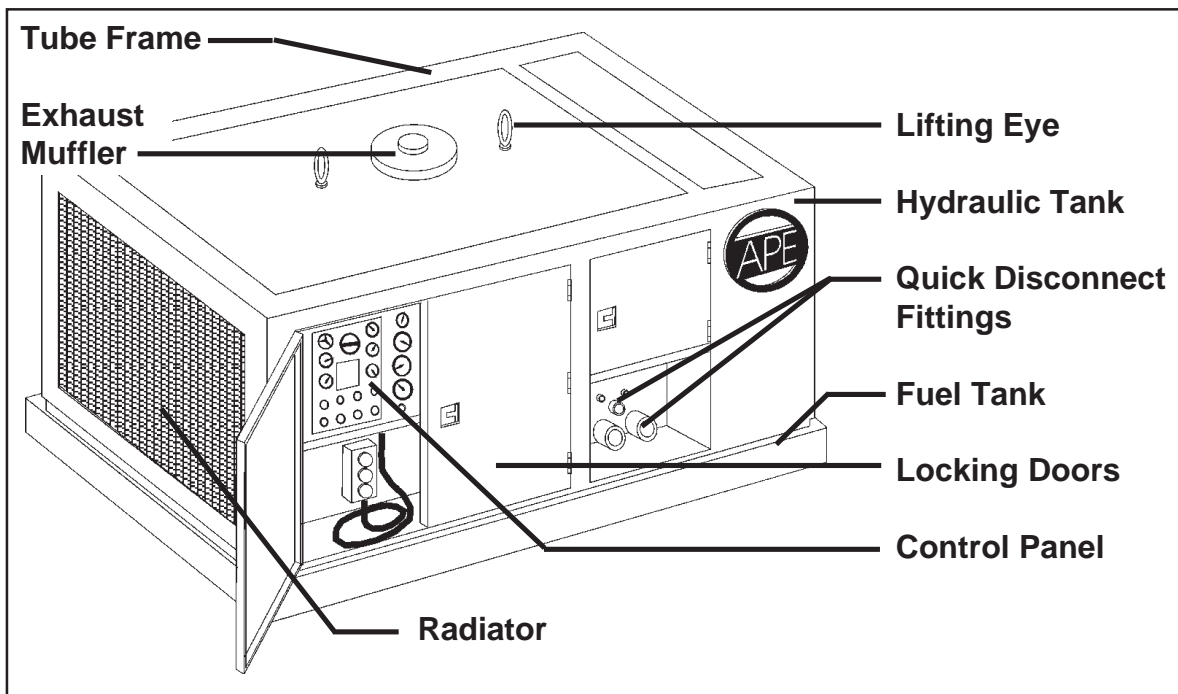
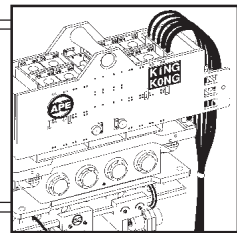

Figure 1-H. General Description of Model 800 Power Unit



II. MAJOR COMPONENT DEFINITION

II-1. Component Identification - Model 400 Vibratory Hammer.

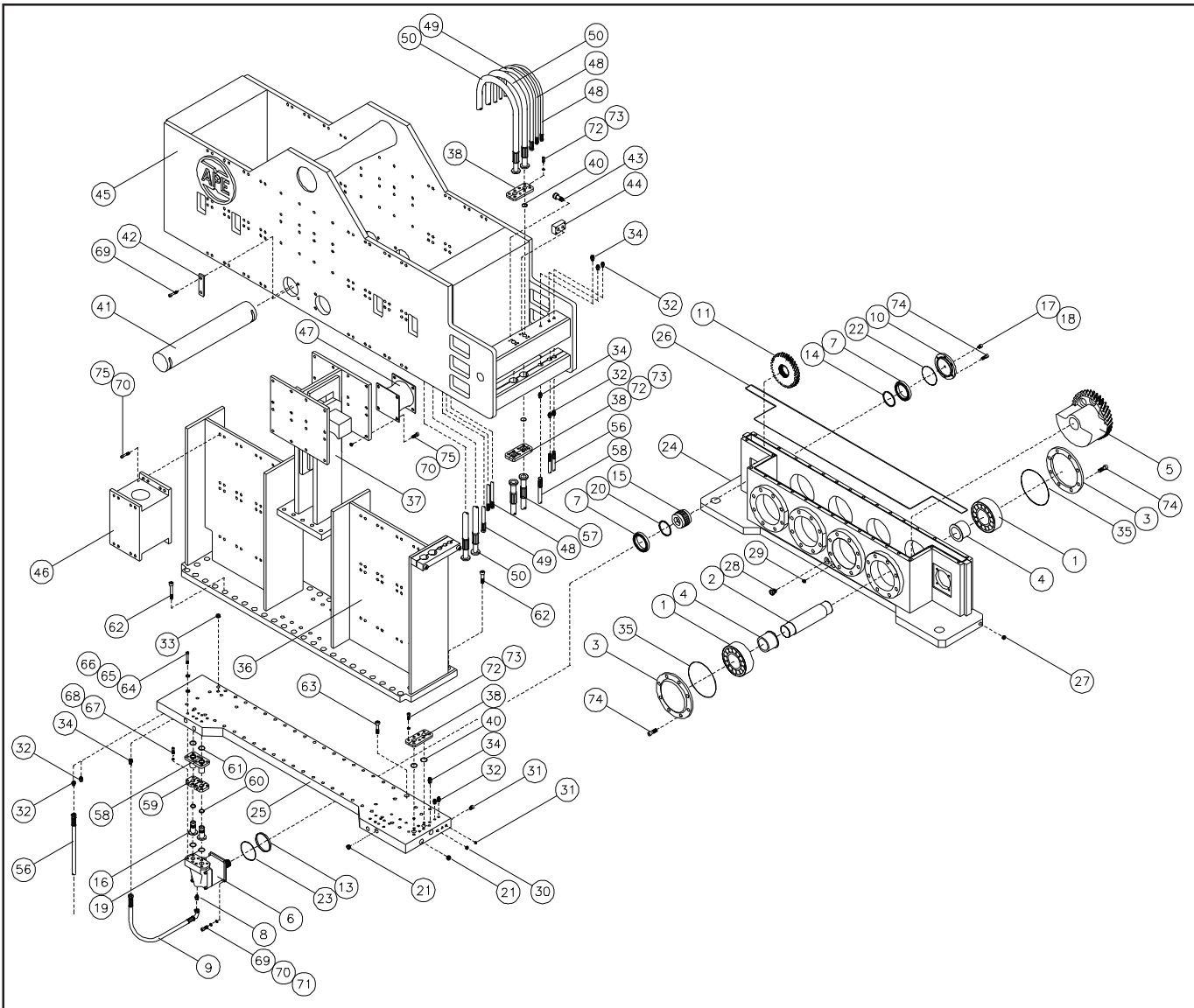
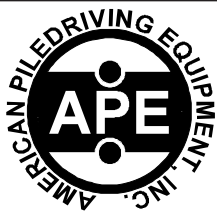

Figure 2-A. Component Identification - Model 400 Vibratory Hammer.



OPERATION / MAINTENANCE MANUAL

MODEL 400 VIBRATORY HAMMER WITH MODEL 800 POWER UNIT

7032 So. 196th - Kent, WA. 98032 - (206) 872-0141 / Fax (206) 872-8710

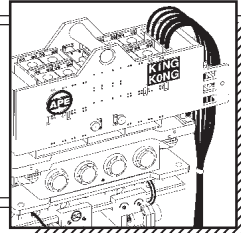

II. MAJOR COMPONENT DEFINITION (Continued...)

II-1. Component Identification.

The following is a general listing of the APE Model 400 Major components and part numbers. (Please see Figure 2-A. for component location.)

Table 2-A. Component Identification.

Item	Qty	Description	Part #
1	8	Model 400 Eccentric Bearing	#141001
2	4	Eccentric Shaft	#141003
3	8	Eccentric Bearing Cover	#141004
4	8	Eccentric Bearing Sleeve	#141005
5	4	Eccentric Weight - Model 400	#141007
6	2	Vibratory Motors	#142001
7	2	Motor Bearing	#142002
8	2	Fitting #F40X-S-812MJICxMBSPP	#142003
9	2	Motor Hose Assembly	#142004
10	2	Motor Bearing Cover	#142005
11	1	Drive Gear - Left	#142006
12	1	Drive Gear - Right	#142007
13	2	Bearing Spacer	#142008
14	4	Gear Spacer	#142009
15	2	Gear Carrier	#142010
16	4	Hydraulic Motor Adapter	#142018
17	1	#10 SAE Breather Plug	#122014
18	1	Breather Valve	#122015
19	4	Parker O-Ring #2-225	#122027
20	2	Gear Spacer (Narrow)	#142011
21	8	#32 SAE Socket Drive Plug	#143007
22	2	Motor Cover O-Ring #2-258	#142019
23	2	Motor O-Ring #2-163	#142020
24	1	Vibratory Gearbox	#143001
25	1	Top Plate	#143002
26	1	.070 C/S BUNA 70 CORD O-Ring	#143003
27	2	Magnetic Drain Plug	#123004
28	1	Sight Gauge	#123005
29	1	Gearbox Oil Level Plug	#123006
30	2	#20 SAE Socket Drive Plug	#123007
31	8	#8 SAE Socket Drive Plug	#123008
32	2	#8 SAE / #6 JIC Fitting	#123009
33	1	Oil Fill Plug	#123012
34	2	#12 SAE / #12 JIC Fitting	#123013
35	8	Bearing Cover O-Ring #2-276	#141008
36	1	Suppressor Mounting Base	#340102
37	1	Lifting Bracket	#340103
38	3	Double Split Flange	#123018
39	1	Bolt Kit	#144000
40	6	Flange O-Ring #2-225	#143020
41	2	Center Pin	#341006
42	2	Keeper Plate	#341007
43	1	Pop-Off Valve	#321009
44	1	Check Valve	#321015
45	1	Suppressor Housing	#340101
46	16	Large Elastomers	#321003
47	8	Small Elastomers	#321004

Item	Qty	Description	Part #
48	2	Hose, Suppressor, Clamp 3/8" 3 Wire x 12' w/6-6FJX ea. end.	#440103
49	1	Hose, Suppressor, Case Drain 1 1/4" 100R2AT x 12' Coupled HL20-20NJ ea. end.	#440102
50	2	Hose, Suppressor, Motor Feed 2" 100R13 x 12' Coupled ER32-32PH ea. end.	#440101
56	6	Hose, Clamp Line 3/8" 3 Wire x 6' w/6-6FJX ea. end.	#421004
57	2	Hose, Pigtail, 2" 100R13 x 6' ER32-32PH & ER32-32NJ ea. end.	#441007
58	4	Hydraulic Flange Coupling	#142012
59	4	Hydraulic Motor Split Flange	#142017
60	4	Parker "Polypak" #18701750-375	#142019
61	4	Parker O-Ring #2-332	#142020
62	---	Bolt-SHCS 3/4"NC x 6"	#144104
63	---	Bolt-SHCS 3/4"NC x 2 1/4"	#144303
64	---	Bolt-SHCS 7/16" x 4 1/2"	#144108
65	---	Flat Washer - 7/16"	#144110
66	---	Lock Washer - 7/16" High Collar	#144111
67	---	Bolt M14 x 30	#144112
68	---	Lock Washer M14	#144117
69	---	Bolt-SHCS 3/4"NC x 1 1/2"	#144101
70	---	Flat Washer - SAE 3/4"	#144305
71	---	Lock Washer 3/4" High Collar	#144105
72	---	Bolt-SHCS 5/8"NC x 2"	#144114
73	---	Lock Washer 5/8" High Collar	#144115
74	---	Bolt-SHCS 1/2"NC x 1"	#144107
75	---	Bolt-SHCS 3/4"NC x 2 1/4"w/Nut	#144303
76	-	-	#
77	-	-	#
78	-	-	#
79	-	-	#
80	-	-	#
81	-	-	#
82	-	-	#
83	-	-	#
84	-	-	#
85	-	-	#
86	-	-	#
87	-	-	#
88	-	-	#
89	-	-	#
90	-	-	#



OPERATION / MAINTENANCE MANUAL

MODEL 400 VIBRATORY HAMMER WITH MODEL 800 POWER UNIT

7032 So. 196th - Kent, WA. 98032 - (206) 872-0141 / Fax (206) 872-8710

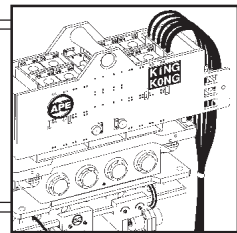

II. MAJOR COMPONENT DEFINITION (Continued...)

II-2. Hose Bundle Identification.

The following is a general listing of the standard hoses that are shipped with the APE Model 400 Vibratory Hammer. (Please see Figure 2-B. for component location.)

Table 2-B. Hose Bundle Identification.

Item	Qty	Description	Part #
1	2	2" Red Hose x 50'	#441008
		2"XT5 CAT Hose #ER2424NJ Ea	End
2	2	2" Red Hose x 50'	#441008
		2"XT5 CAT Hose #ER2424NJ Ea	End
3	2	1 1/4" Two Wire Hose x 50'	#421009
4	4	3/8" Gates Hose x 50'	#421010
		w/#HU66NJ Ea. End	
5	1	Fitting #6 JIC Male/#6 Female	#421011
6	4	Fitting #32 Male JIC Union	#441012
7	2	Fitting #20 Male JIC Union	#441013
8	6	Fitting #6 Male JIC Union	#421014
9	2	Fitting #32 JIC/#24 Pipe	#441015

Item	Qty	Description	Part #
10	1	Fitting#12 JIC/#20 Pipe	#441016
11	1	Fitting #6 JIC/#6 Pipe Male	#421017
12	1	Aeroquip Male Q.D. #5100S112B	#421020
13	1	Aeroquip Dust Cap #5100S712B	#421021
14	2	Safeway Female Q.D. #S35-3	#421024
15	2	Safeway Male Q.D. #S31-3	#421025
16	2	Safeway Cap #S39-3	#421026
17	2	Safeway Plug #S34-3	#421027
18	2	Q.D. Hydraulic Female Coupling	#441301
19	2	Q.D. Hydraulic Male Coupling	#441303
20	1	APE Dust Plug	#441022
21	1	APE Dust Cap	#441021

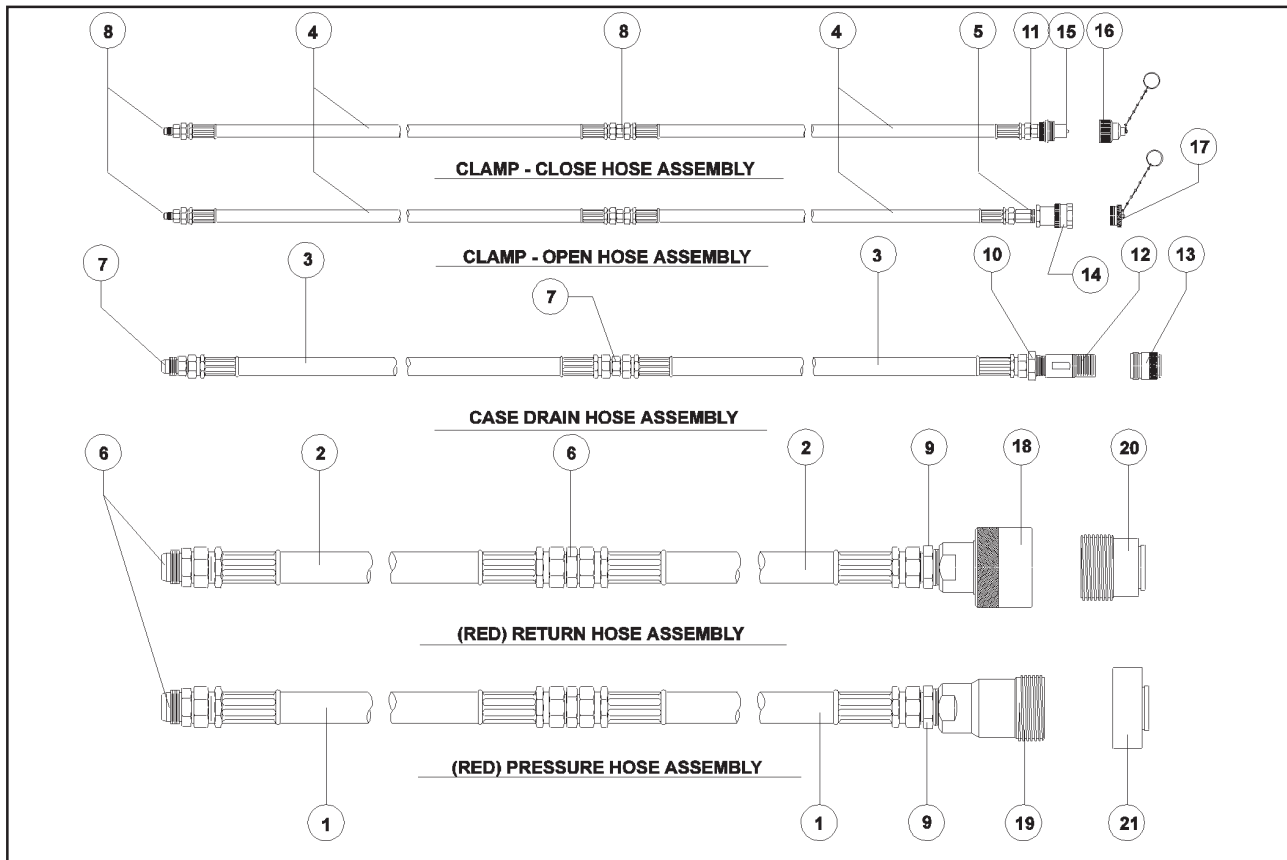



OPERATION / MAINTENANCE MANUAL

MODEL 400 VIBRATORY HAMMER WITH MODEL 800 POWER UNIT

7032 So. 196th - Kent, WA. 98032 - (206) 872-0141 / Fax (206) 872-8710

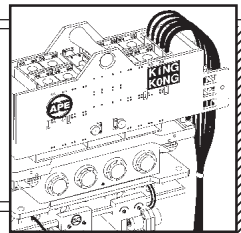

II. MAJOR COMPONENT DEFINITION (Continued...)

II-3. Caisson Clamp Identification.

The following is a general listing of the parts for the APE Caisson Clamp and Beams. (Please see Figure 2-C. for component location.)

Table 2-C. Caisson Clamp Identification

Item	Qty	Description	Part #
1	1	Caisson Clamp Body	#250101
2	6	Grease Zert	#221001
3	1	Caisson Clamp Plunger/Jaw	#250301
4	1	Caisson Clamp Fixed Jaw	#250202
5	2	Bolt - SHCS 5/8" x 4"	#124214
6	2	Lock Washer 5/8" High Collar	#124115
7	2	Male Wedge Half	#243102
8	2	Female Wedge Half	#243105
9	2	Wedge Bolt w/Washer	#124211
10	2	Wedge Nut w/Washer	#124212
11	17	Bolt - SHCS 1 1/2" x 3 1/2"	#124201
12	17	Lock Wa. - 1 1/2" High Collar	#124202
13	1	Clamp Cylinder	#250001
14	2	#6 SAE/#6 JIC 45 Deg. Fitting	#222002
15	8	Bolt - SHCS 1 1/4"NFx3 1/2"GR.8	#124204
16	8	Lock Wa. - 1 1/4"High Collar	#124205
17	1	Cylinder End Cap	#250302

Item	Qty	Description	Part #
18	1	Cylinder Piston	#250303
19	1	Plunger	#250301
20	1	Bolt -SHCS 1 1/2-8 x 3"	#250304
21	1	Wiper - #959-41	#
22	1	Caisson Beam 11ft.	#903000
23	1	Poly Seal - #2500-4500-375B	#
24	12	Bolt - SHCS 5/8-18 x 1"	#
25	8	Spring Pin	#250103
26	4	Wedge Spring	#250104
27	1	Wear Ring - #W2-4750-750	#
28	1	Hydraulic Wedge Activator Kit	#243100
29	1	Parker O-Ring #8-367	#
30	1	Parker O-Ring #2-367	#
31	1	Piston O-Ring #2-338	#
32	1	Piston Wear Ring #W2-8000-750	#
33	1	TFER8000 Bronze w/Loader Ring	#
34	1	Square Ring - #4426	#

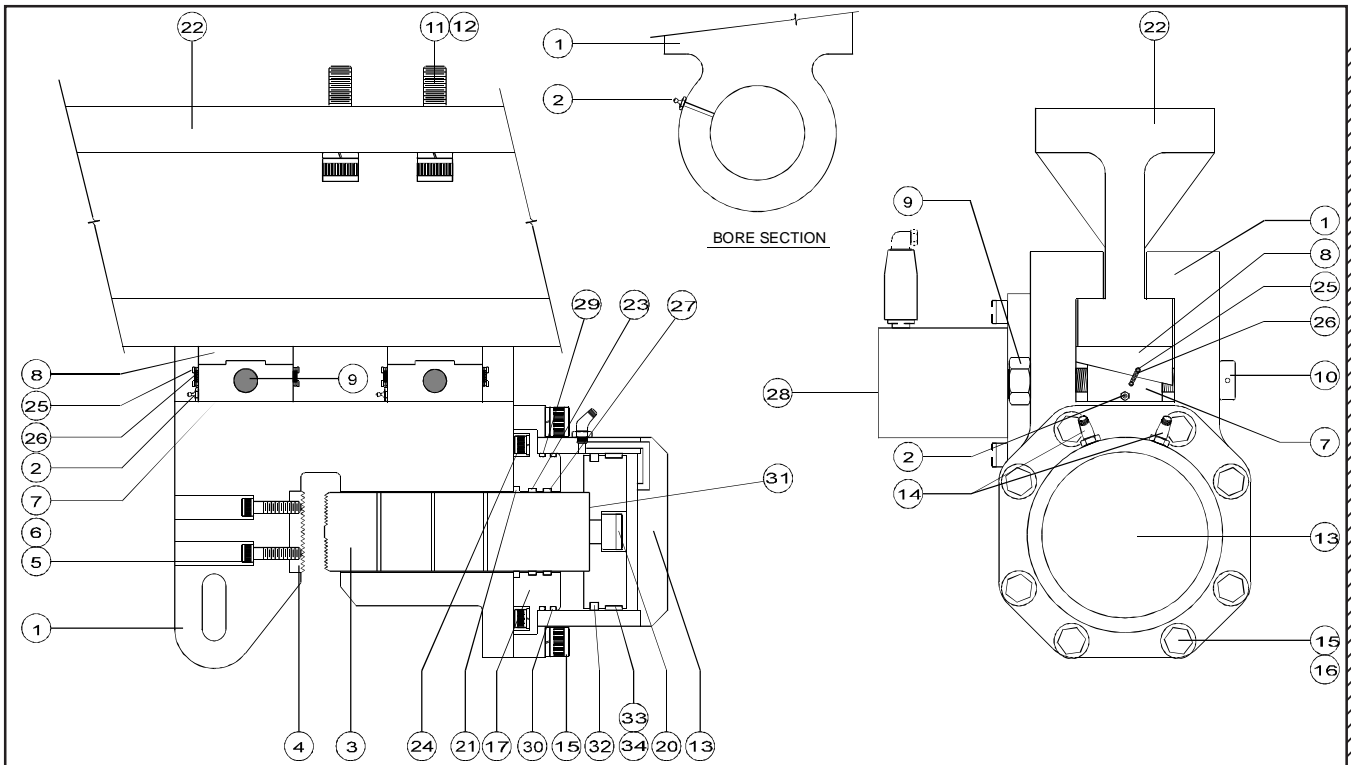
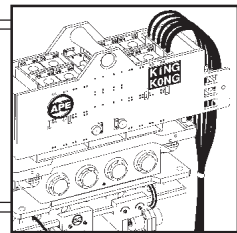

Figure 2-C. Caisson Clamp Identification.



II. MAJOR COMPONENT DEFINITION (Continued...)

II-4. Model 800 Power Unit Skid Identification.

Table 2-D. Model 800 Power Unit Skid Identification

Item	Qty	Description
1	1	Model 800 Power Unit Skid
2	1	Radiator Grill
3	1	Door 28 1/4" x 85 1/2"
4	1	Door 21 1/2" x 85 1/2"
5	1	Door 21 1/2" x 85 1/2"
6	1	Door 24 7/8" x 85 1/2"
7	1	Door 29 1/2" x 85 1/2"
8	1	Door 25 1/2" x 50 1/2"
9	2	2" Hydraulic Coupling
10	1	1 1/4" Hydraulic Coupling
11	2	3/4" Hydraulic Coupling
12	10	Door Handle / Lock
		Lock-#EMC 56462W Two Point Lock
		Handle-#EMC 48742W Locking Handle
13	29	Hinges #R140-150 Weld On Hinge
14	2	Lifting Eye Nuts - Crosby Laughlin #6-400 #10
15	1	Cover Plate 12" x 15"
16	1	Cover Plate 15" x 18"
17		
18		
19		
20	1	APE Dust Plug #441022
21	1	APE Dust Cap #441021

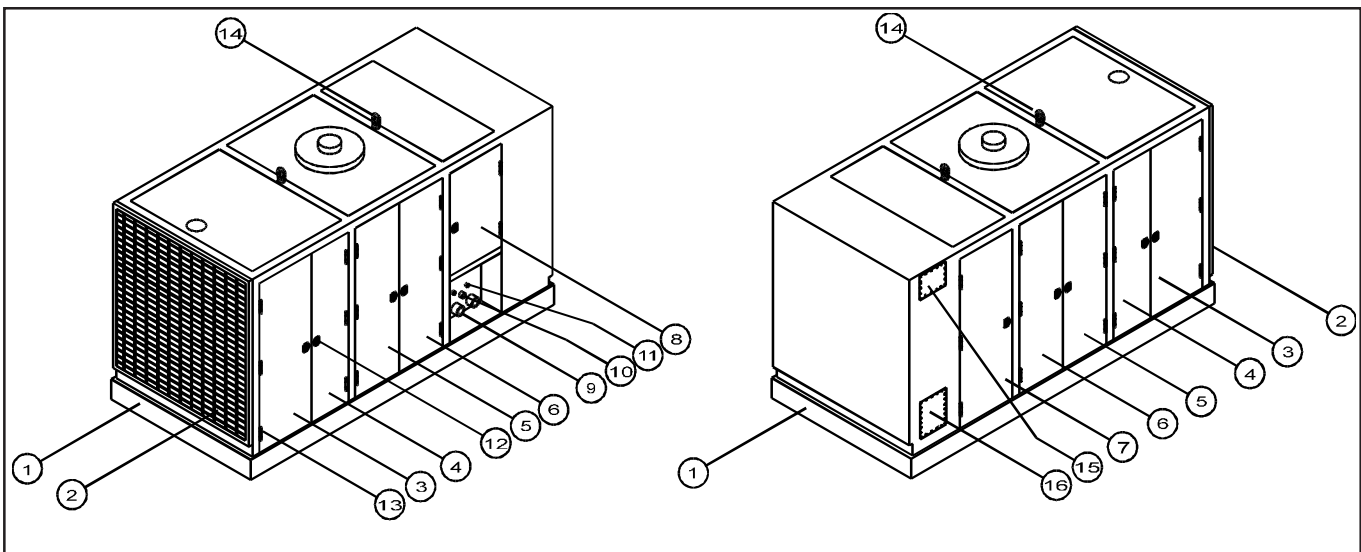
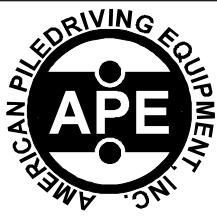

Figure 2-D. Model 800 Power Unit Skid Identification.



OPERATION / MAINTENANCE MANUAL

MODEL 400 VIBRATORY HAMMER WITH MODEL 800 POWER UNIT

7032 So. 196th - Kent, WA. 98032 - (206) 872-0141 / Fax (206) 872-8710

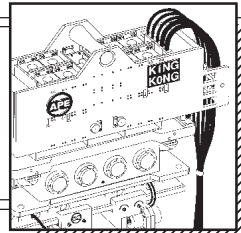

II-5. Quick Disconnect Couplings. - Figure 2-E.

The 5TV series high pressure hydraulic coupling is designed for rugged hydrostatic drive applications in the mining and oil industries. Service in many such applications has proven the design compatible to extreme pressures, structural and system induced shockloads. The construction makes the coupling attractive in applications having low operating pressures. NOTE - Not for use with gaseous fluids.

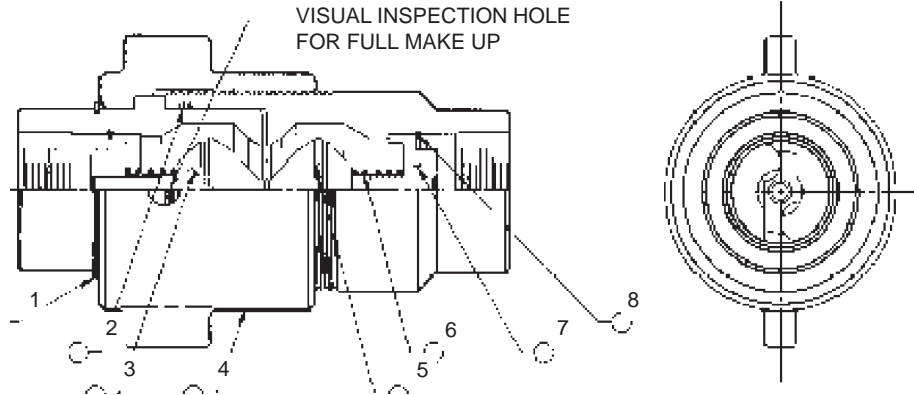

Figure 2-E. Quick Disconnect Coupling Identification.

- 1 NUT RETAINER RING
- 2 NIPPLE SEAL (O-RING/BACK UP RING)
- 3 POPPET VALVE
- 4 HIGH STRENGTH CAST STEEL NUT

- 5 VALVE SEAL SWAGED IN AGAINST WASHOUT
- 6 VALVE SPRING
- 7 EXCLUSIVE FOUR POINT CONTACT POPPET GUIDE
- 8 2-TURN LOCK RING

OPERATING LIMITS

- 5,000 P.S.I. operating pressure - all sizes
- 20,000 P.S.I. minimum burst - coupled
- Vacuum to 28" Hg
- Standard seal - temperature range -65OF to +250OF
- Buna-N seals - standard

DESIGN FEATURES

- Excellent flow characteristics for continuous duty applications. See flow chart.
- High strength steel poppet guides prevent break up and washout of coupling valving during high surge and shock conditions.
- Exclusive four point support design of poppet guide provides positive alignment of valving during surging flow conditions.
- Flat crested stub-acme threads and all steel construction withstand storage and rig-up damage.
- Protective treatment equal to industry standards for SAE steel hose fittings.
- Structurally compatible with weight of 5,000 P.S.I. flex-hose and system induced shockloads.

SIZES AND CONNECTION TYPE

- 3/4" thru 3' - female NPTF pipe thread

PRESSURE DROP vs FLOW (GPM) - COUPLING

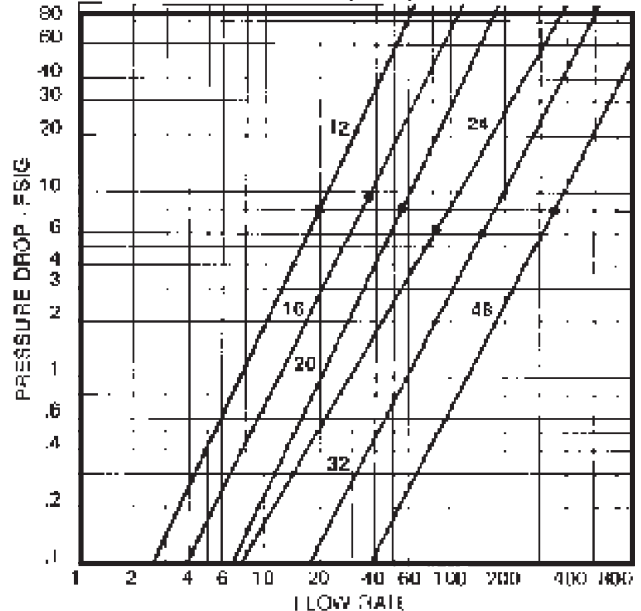

- Pressure drop thru coupling based on flow giving 15 FPS fluid velocity thru nominal bore size.

COUPLING PART NO.	DUST PLUG PART NO.	DUST CAP PART NO.	VALVE ASS'Y PART NO.	NIPPLE SEAL PART NO.
5TV-CN-32	5TV-DP-32	5TV-DC-32	5TV-VA-32	5TV-NS-32

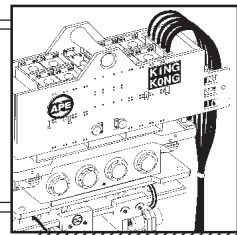

II. MAJOR COMPONENT DEFINITION (Continued...)

II-6. Tool Set Identification.

Mounted inside the **Model 800 Power Unit** is a set of tools frequently used for the maintenance of the **APE Model 400 Vibratory Hammer**. The following figure and table shows the location and the use for each tool.

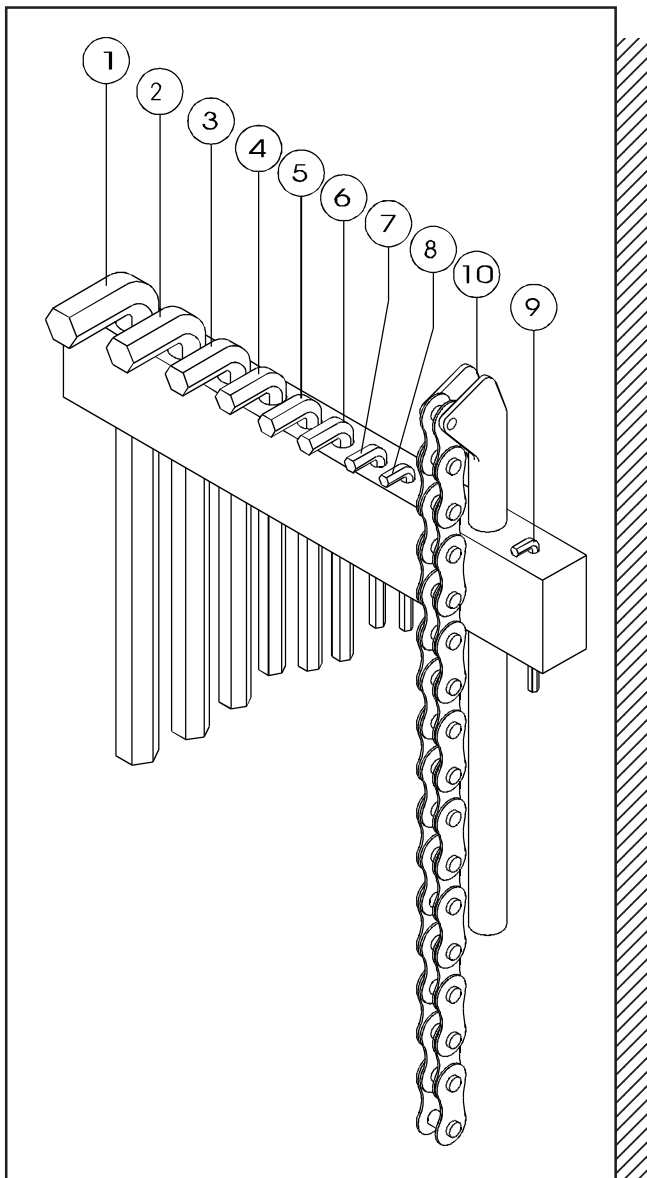
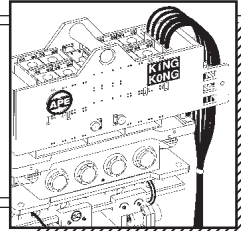

Table 2-E. Tool Set Identification.

ITEM	QTY	DESCRIPTION	PART#
1	1	1" Allen Wrench	#950002
For use with the clamp attachment bolts			
2	1	7/8" Allen Wrench	#950003
For use with the drain plug & sheet guide			
3	1	3/4" Allen Wrench	#950004
For use with the clamp fixed jaw bolts			
4	1	5/8" Allen Wrench	#950005
For use with the hydraulic motor mnt. bolts			
5	1	9/16" Allen Wrench	#950011
For use with the hose bracket bolts			
6	1	1/2" Allen Wrench	#950006
For use with the suppressor top plate bolts			
7	1	3/8" Allen Wrench	#950007
For use with the bearing cover bolts			
8	1	5/16" Allen Wrench	#950012
For use with the hose bracket bolts			
9	1	Chain Wrench	#950009
Used to tighten the quick disconnects			
10	1	1/4" Allen Wrench	#950013
For use with the vibro oil level check			

Figure 2-F. Tool Set Identification.



II. MAJOR COMPONENT DEFINITION (Continued...)

II-7. Caisson Clamp Wedge Actuator.

The following is a listing of the Caisson Clamp Wedge Actuator components and locations.

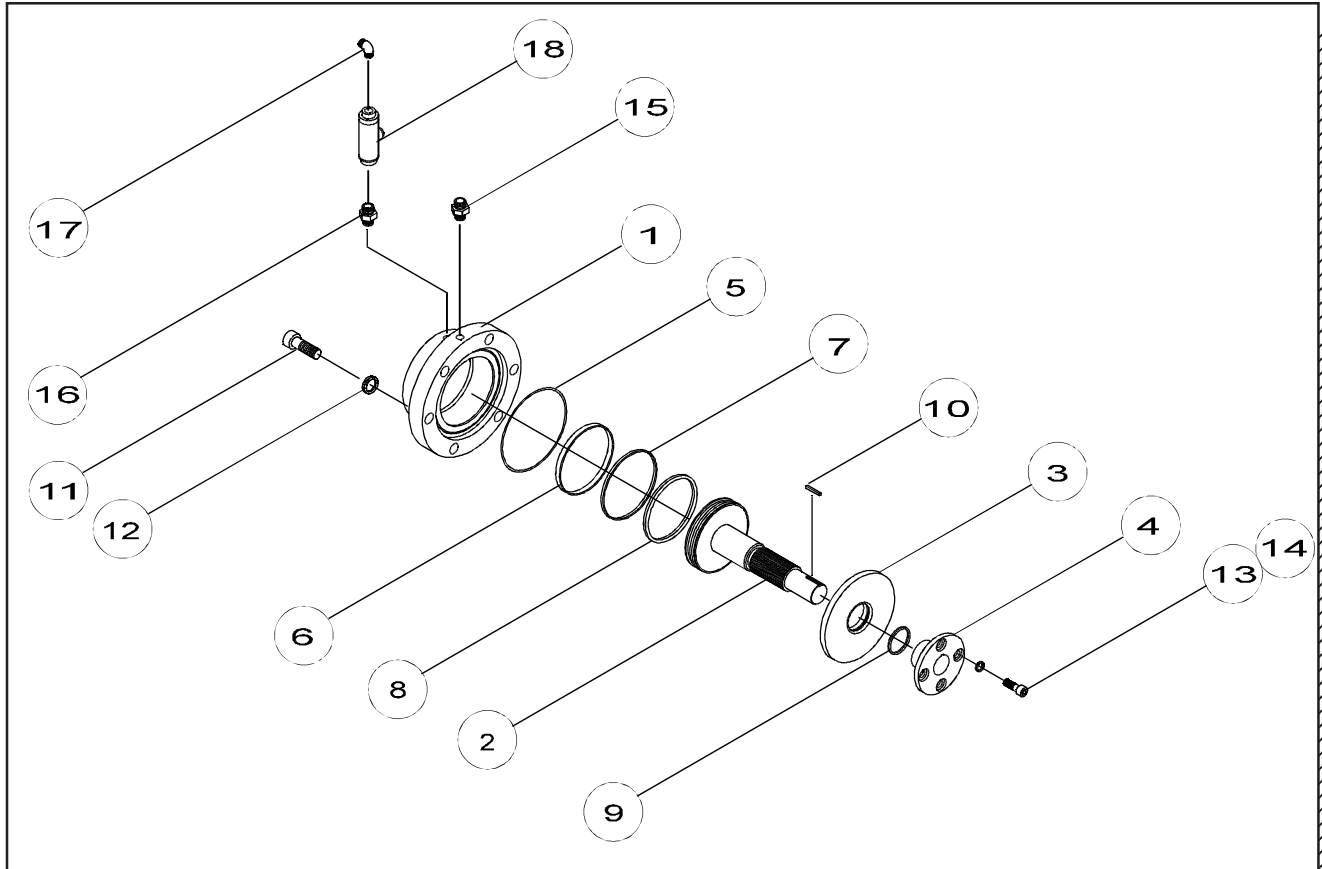

Figure 2-G. Caisson Clamp Wedge Actuator.

Table 2-F. Caisson Clamp Wedge Actuator.

Item	Qty	Description	Part #
1	1	Wedge Cylinder	#243001
2	1	Wedge Piston	#243006
3	1	Cylinder Flange	#243003
4	1	Support Bushing	#243004
5	1	O-Ring Parker #2-242	#243011
6	1	Wear Ring #W2-12503500-375	#243012
7	1	#TFES-3500 Piston Ring	#243013
8	1	Loader Ring	#243014
9	1	Poly-Seal Parker #1250-1375	#243015

Item	Qty	Description	Part #
10	1	Key Stock 1/4" x 1/4" x 1"	#243007
11	6	Bolt - SHCS 1/2"-13 x 2 1/2"	#244001
12	6	Lock Washer 1/2"	#244002
13	4	Bolt - SHCS 3/8"N.C. x 1"	#244003
14	4	Lock Washer 3/8"	#244004
15	1	Fitting #6SAE/#6JIC	#123014
16	1	Fitting 3/8"Pipe/#6JIC	#243016
17	1	90deg. Fitting 3/8"Pipe/#6JIC	#243017
18	1	Check Valve	#243106



OPERATION / MAINTENANCE MANUAL

MODEL 400 VIBRATORY HAMMER WITH MODEL 800 POWER UNIT

7032 So. 196th - Kent, WA. 98032 - (206) 872-0141 / Fax (206) 872-8710

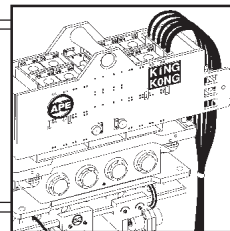

III. LOADING AND UNLOADING

III-1. Model 400 Vibratory Hammer.

The APE Model 400 vibrator is normally shipped standing up on the trailer deck with the beam and clamps removed and the hose bundle coiled next to it. Lift the vibrator by rigging one line to the lifting pin lifting the vibro and hose bundle as one load. Avoid smashing hydraulic lines. Vibro should be loaded standing as mentioned earlier. Before the truck has left, carefully inspect the machine and hoses for any missing equipment or sign of damage that may have occurred during shipment or unloading.

III-2. Model 800 Power Unit.

The Power Unit is always loaded with the oil cooler facing to the rear of the truck to prevent damage to the cooler and the radiator from flying objects. The Power Unit is usually held to the truck by wrapping a chain around both ends of the fuel tank base and the truck bed. After loading the Power Unit, tape the exhaust rain cap shut to prevent rain water from getting inside. If quick disconnects do not have safety cables then store them under the panel in the storage box rather than risk the possibility of the caps and plugs coming loose and falling off into traffic. Make sure all doors are fully closed. Tighten fuel cap to prevent diesel fuel from washing out the fill spout.

III-3. What to do if damaged during shipment.

In the event of damage, notify the trucking agent at once. Note all damage on the bill of lading. Fax the information as soon as possible, any delay may make it impossible to find the responsible party.



OPERATION / MAINTENANCE MANUAL

MODEL 400 VIBRATORY HAMMER WITH
MODEL 800 POWER UNIT

7032 So. 196th - Kent, WA. 98032 - (206) 872-0141 / Fax (206) 872-8710

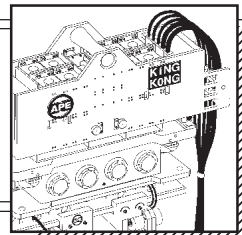

IV. PREPARATION AND OPERATION

IV-1. Rigging of Vibratory Hammer

A steel wire rope sling must be connected to the lifting bail located on top of the vibro. The required strength of this sling depends on the capacity of the crane and the work to be carried out. A safety factor of six is recommended. Several turns of a smaller diameter cable will result in a longer lasting sling than one larger diameter cable. When making a sling, avoid using cheap cable clamps. Check the clamps daily.

IV-2. Installing the Clamp Attachment

Several types of clamps are used on APE vibros to fit many different types of piles. A step by step installation procedure is provided as follows:

- 1.) Clean all drilled and tapped threads on the bottom surface of the gearbox. Use a 1 1/2" UNC tap to clean any rusted threads and blow out any remaining fragments with compressed air. If there is a cutting torch on the jobsite then use the oxygen setting to blast the threads clean. Hold a rag over the tapped hole to prevent flying dirt from blasting into your eyes.
- 2.) Clean the machined bottom surface of the gearbox and prepare to mount the clamp. If the clamp bolts should ever break, check the machined surface with a straight edge to make sure it is true and flat.
- 3.) Clean the machined surface of clamp. Eye-ball the entire surface for damage. Make sure the surface is flat and void of all dirt.
- 4.) Start by getting the center bolt in first and work outwards. Do not tighten bolts until you have all of the bolts started.
- 5.) Tighten bolts using a six-foot cheater pipe. If you do not have a cheater pipe then use a sledge hammer.
- 6.) Go around all bolts at least three times making sure they are tight.
- 7.) After vibrating the first pile, check the bolts again.
- 8.) If one bolt breaks, replace them all since they may be weak or cracked.
- 9.) Never operate the vibro with missing clamp bolts.

WARNING: Do not use grade five bolts. All bolts should be allen head cap screw bolts. If one bolt breaks then the others are damaged and must be replaced. Never drive piles if one bolt is broken. Bolts break only because they were not tight and the crew neglected to check them. A good operator insists that every bolt is checked twice daily.



OPERATION / MAINTENANCE MANUAL

MODEL 400 VIBRATORY HAMMER WITH
MODEL 800 POWER UNIT

7032 So. 196th - Kent, WA. 98032 - (206) 872-0141 / Fax (206) 872-8710

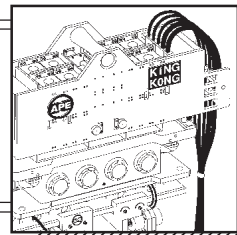

IV. PREPARATION AND OPERATION (Continued...)

IV-3. Plumbing the Vibro Hoses to the Power Unit.

There are five hoses leading from the vibro that must be connected to the power unit to begin operation (Please see section III-2. Hose Identification on [page 2-3] and Figure 2-B on [page 2-4]). There are two big hoses, two little hoses and one middle sized hose. The hoses attach to the power unit by screwing the quick dis-connect couplers onto the proper couplers of the power unit. The couplers on the power unit are mated with the couplers on the vibro so there is no chance of putting them on backwards. Please take the following steps when installing the couplers:

WARNING: TURN THE POWER UNIT OFF BEFORE INSTALLING COUPLERS

- 1.) Turn the power unit OFF.
- 2.) Clean all couplers with a can of ether if available. A clean dry cloth will also work but will require extreme care. Fittings must be spotless clean.
- 3.) Install couplers by screwing them onto their respective counterparts. Try to avoid cross-threading and maintain a straight line. Jerk the hose back and forth while turning coupler to aid installation effort. **Push hard to get the big coupler threads started.**
- 4.) Make sure fittings are tight. If they are properly cleaned they should run up tight with just a firm hand grip. However, they should be double checked with a chain wrench.
- 5.) Avoid over-tightening.
- 6.) If near salt water, spray with a light oil to prevent oxidation.
- 7.) Position the Power Unit so that vibrator has enough hose to reach the work. Avoid pulling too hard on hoses. Most hose failures are caused by pulling hoses off couplers.

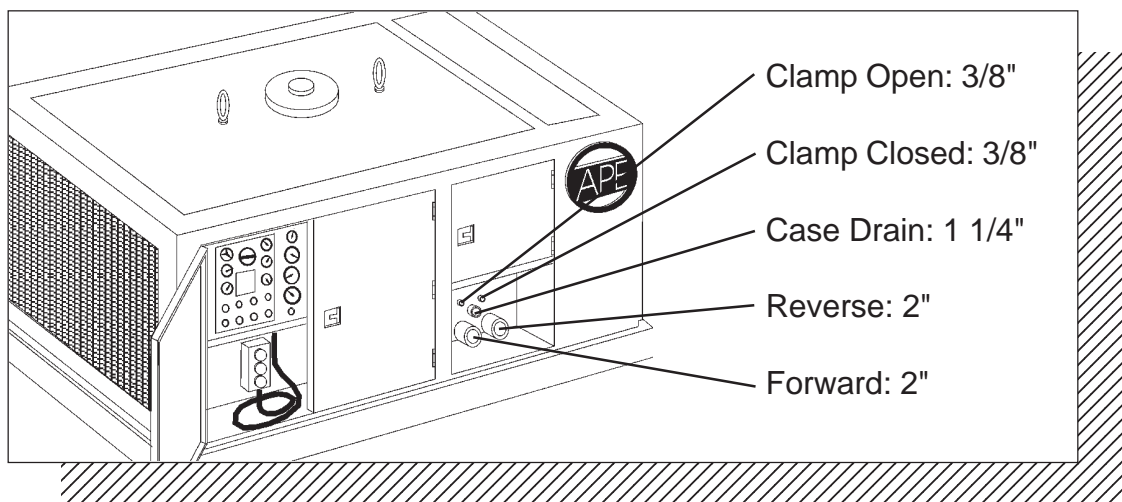
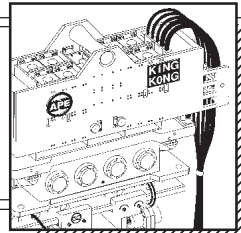

Figure 4-A. Power Unit Coupler Layout



IV. PREPARATION AND OPERATION (Continued...)

IV-4. Filling Vibrator Pressure Hose.

The vibrator is shipped with the hoses filled with oil. However, if the unit has been sitting for a long period of time or if a damaged hose has been replaced with a new one, then the hoses must be filled. Hook up all the hoses to the power unit (see Section IV-3 on [page 4-2] and Figure 4-A.). Start the power unit and let it run for ten minutes before running the vibro. The hoses will fill up by themselves in ten minutes even if the vibro is not in the vibrate mode.

IV-5. Bleeding the Clamp Attachment Hydraulic Hoses.

If the opening and closing of the jaws seems spongy or slow, it may be a result of air in the clamp hoses. Normally there is no need to worry about bleeding the clamp lines because the unit is shipped fully tested. However, should the vibro sit for a long period of time, if a new attachment is being installed or if a damaged clamp hose has been replaced, then the system may require bleeding to remove unwanted air in the system. To bleed the clamp system, follow the steps listed below:

- 1.) Shut Power Unit OFF.
- 2.) Make sure the clamp line quick dis-connects are coupled to the power unit.
- 3.) Start the power unit engine and run at 1500 rpm. Give the engine time to warm up.
- 4.) Loosen the clamp lines at the hydraulic cylinder by backing the fittings off just a little.
- 5.) Turn the clamp switch on the power unit control pendant to "CLOSE" and wait for oil to flow from the fittings. WATCH FOR AIR BUBBLES. When air bubbles have stopped then quickly re-tighten the fittings.
- 6.) Repeat the same procedure for "OPEN" side.
- 7.) Operate the jaws. If they are still a bit spongy then repeat bleeding steps once more.

WARNING: DO NOT BLEED SYSTEM AT FULL ENGINE THROTTLE BECAUSE TOO MUCH OIL WILL FLOW FROM THE HOSES AND COULD CAUSE INJURY.

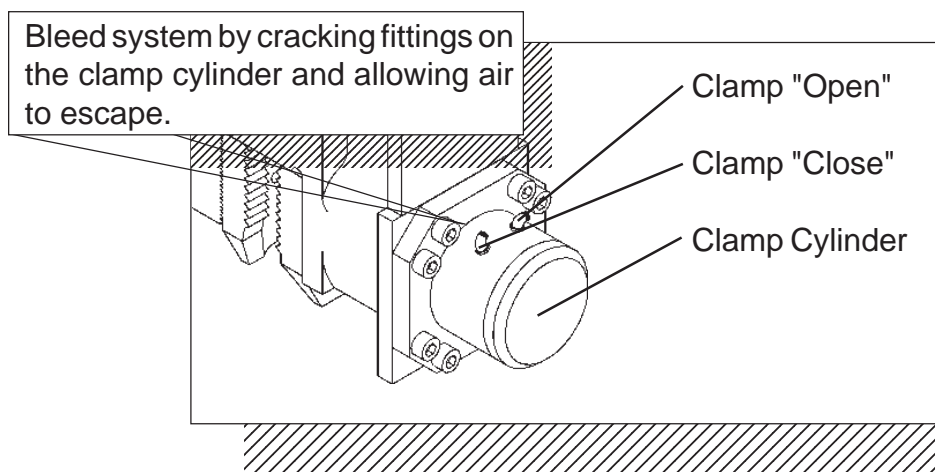

Figure 4-B. Bleeding Clamp Attachment



OPERATION / MAINTENANCE MANUAL

MODEL 400 VIBRATORY HAMMER WITH
MODEL 800 POWER UNIT

7032 So. 196th - Kent, WA. 98032 - (206) 872-0141 / Fax (206) 872-8710

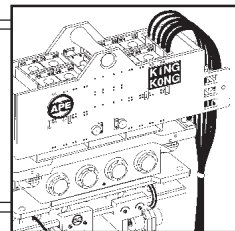

IV. PREPARATION AND OPERATION (Continued...)

IV-6. Precautions and Rules for Operation.

The following is a list of precautions, suggestions and rules that are intended to help promote the safe and productive use of the APE Model 400 Vibratory Hammer.

- 1.) Follow the Daily Maintenance Required Prior to Operation, [Section V-1.] [page 5-1].
- 2.) Read and follow the Safety Precautions, [page iii].
- 3.) Follow the start-up procedures listed in the manual for the power unit being used.
- 4.) Start with piles in good condition.
- 5.) Put all teeth in pile.
- 6.) Drive in steps eight feet or less.
- 7.) Keep sheets plumb.
- 8.) Come up to speed before doing work.
- 9.) No dancing. Avoid de-intensification.
- 10.) Drive past obstacles and then go back.
- 11.) Backhoe on site to remove obstacles.
- 12.) Lead with the ball.
- 13.) Probe the pile if it appears stuck.
- 14.) Keep piles plumb or down the road you go.
- 15.) Never rush the sheet pile foreman.
- 16.) Slow and plumb and the job will get done.
- 17.) Melted inner locks - piles out of plumb.
- 18.) Never stand under pile hammers.
- 19.) Low clamp pressure means jaw failures.
- 20.) Wait for vibro to get to full speed then pull.
- 21.) Don't over excavate - lower the ring.
- 22.) Look at the jaws during driving.
- 23.) Beware of cracked or broken sheets.
- 24.) In sandy soils drive faster.
- 25.) In clay amplitude is everything.
- 26.) Low drive pressure means easy work.
- 27.) High pressure means friction on piles.
- 28.) Over 5000 psi means get a bigger hammer.
- 29.) No amplitude means get a bigger hammer.
- 30.) Caissons need heavy wall to avoid flex.
- 31.) Check clamp bolts each morning.
- 32.) Read the manual - know your machine.
- 33.) Attach whip line to pile when pulling.
- 34.) Know your line pull.
- 35.) Extract straight - look at boom and cable.
- 36.) Give boom stops some room.
- 37.) Stalled engine means dirty fuel filters.



OPERATION / MAINTENANCE MANUAL

MODEL 400 VIBRATORY HAMMER WITH
MODEL 800 POWER UNIT

7032 So. 196th - Kent, WA. 98032 - (206) 872-0141 / Fax (206) 872-8710

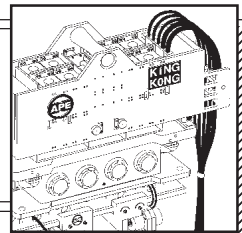

IV. PREPARATION AND OPERATION (Continued...)

IV-7. Relief Valve Settings Prior to Operation - Model 800 Power Unit.

1. Do not hook up quick disconnects. Start engine and bring to full rpm.
2. Check Clamp relief valve setting by turning clamp switch to "open" and holding it there while you read the clamp "open" gauge on the panel. The gauge should read 4300 psi. If it is not coming up to pressure then set the relief valve (FACTORY AUTHORIZED PERSONNEL ONLY) by loosening the lock nut and turning the knob in slowly until the proper pressure is reached. Turn in to increase pressure and out to decrease pressure. Lock the locknut and re-check the pressure to make sure that you did not move the setting while you were tightening the lock nut. When you turn the clamp switch to "open" and hold it, a small light on the solenoid comes on to show that there is power to the solenoid. The solenoid light should go off when you turn it to the "Off" position.
3. Check the clamp pressure switch setting. Turn the clamp to "close" and see if the green light comes on indicating proper clamp pressure. If it does then everything is fine. Clamp pressure should read 4000 psi and light on pendant or panel should be lit. To set the pressure switch, turn the set screw out using a screwdriver. Turn it out a few turns counter clockwise. Turn clamp switch to "open" for a second. Make sure the clamp open gauge reads 4300 psi. If it does not then go back to step 2 and set the clamp relief valve first. Knowing that your clamp relief valve is set to 4300 psi, turn the clamp switch to "closed." Green light should be on and clamp pressure should be very low or not reading at all. If green light is on then slowly turn the pressure switch screw clockwise with a screw driver until the pressure is 4000 psi or 300 psi below the clamp relief valve setting. Always set the clamp pressure switch 300 psi below the clamp relief valve setting or the light will never come on. We do not want the clamp pump to pump oil over the relief valve because this will cause heat and take away 25 horsepower from the engine. Call the factory if you have any questions. (800) 248-8498

IV-8. Shut-down Procedures.

The following procedures explain what to do with the power unit to correctly shut down the APE Model 400 Vibratory Hammer. (Please refer to the operating manual of the power unit for control locations and operation procedures.)

- 1.) Stop the vibrator. (Refer to the power unit operating manual .)
- 2.) Allow the diesel engine to run for five minutes at 1000 engine rpms.
- 3.) Reduce engine speed to low idle for about 60 seconds.
- 4.) Shut engine off by turning off the main power switch.

WARNING: Do not shut the power unit engine down while the vibrator is clamped onto a pile. The clamp check valve will slowly bleed off if there is any leakage in the hose lines or worn clamp seals in the cylinder that moves the jaw open or closed.



OPERATION / MAINTENANCE MANUAL

MODEL 400 VIBRATORY HAMMER WITH
MODEL 800 POWER UNIT

7032 So. 196th - Kent, WA. 98032 - (206) 872-0141 / Fax (206) 872-8710

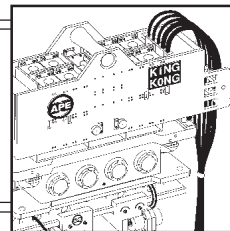

IV. PREPARATION AND OPERATION (Continued...)

IIV-9. Operation of the Remote Control Pendant.

1. All functions of the vibro can be controlled by the hand held pendant. It is the choice of the crew as to where best to locate the pendant. Some prefer to give it to the crane operator so he can control all functions. Others prefer to give it to one of the ground crew so that he can position himself close to the work at hand. A 50 foot cord is provided as standard equipment. If this is not long enough, additional 50 foot sections can be added. Should the pendant become damaged, all functions can be manually operated. See Section VII-3, Page 7-8 in this manual for more details on operation. See Section VII-3A, Page 7-9 of this manual for wiring diagram and pendant components.

IV-10. Normal steps to operate vibrator:

1. Position vibro on pile.
2. Turn clamp switch to Close and wait for light to come on pendant.
3. Turn to Forward to begin vibrating pile.
4. To drive, lower crane line as vibro vibrates pile.
5. To extract, pull up on vibro while vibrating.
6. See "Precautions and Rules for Operation" in this manual for more detailed operations on driving and extracting piles.
7. To stop the vibro turn the Forward switch to off.
8. To release clamp, press clamp switch clamp light will turn off.

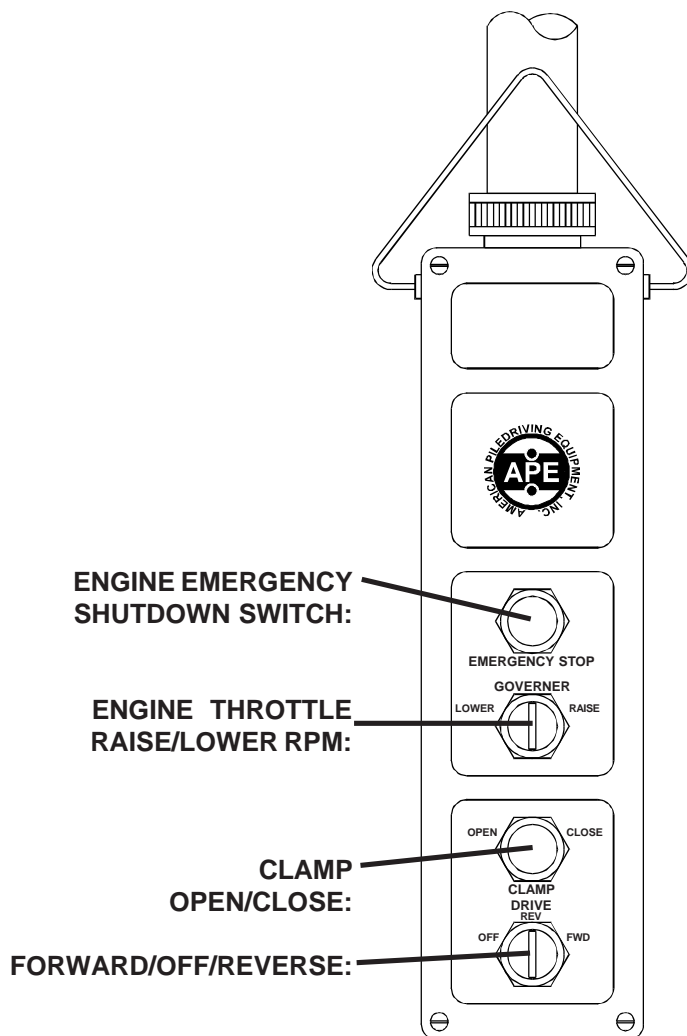

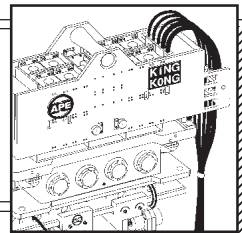

V. MAINTENANCE

V-1. Daily Maintenance Required Prior to Operation.

- 1.) Visually inspect the entire vibro for loose nuts or bolts. Put a wrench on the clamp bolts and check them for tightness.
- 2.) Grease the Jaw Plunger on the clamp housing.
- 3.) Check the oil level in the vibrator. Hang vibro from crane and look at sight gauge. Make sure the oil is half way up gauge. If you cannot read it then you can't run the vibro. Remove the gauge and clean it by spraying a shot of starting fluid at it. **YOU MUST KNOW THE LEVEL!**

IF THE OIL LOOKS BLACK OR MILKY THEN DRAIN THE GEARCASE AND ADD NEW HYDRAULIC OIL.

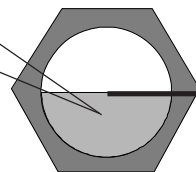

**Oil Level
Chevron AW46 or equal.**

Sight Gauge

- 4.) If the oil is milky or black then change it. **Change the oil every 75 hours regardless.**
- 5.) Check the fluid level in the power unit hydraulic tank.
- 6.) Look at all the hoses. Check for cuts or other damage that might cause an oil leak.
- 7.) Check the rubbers in the suppressor housing. Look for cracks.
- 8.) Perform all start up checks as per the "start-up procedures" in the Power Unit manual.

V-2. Checklist After Power Unit Engine Has Started

- 1.) Check all hydraulic hoses for leaks. Make sure they hang free with no kinks.
- 2.) Check inside the Power Unit. Look at all hoses and valves, check for leaks.
- 3.) Check filter indicator with engine running at full rpm. Replace if necessary.
- 4.) Check wire rope sling and make sure it is in excellent condition.
- 5.) Check jaws for wear. Replace if necessary.
- 6.) Close jaws, make sure clamp light comes on.



OPERATION / MAINTENANCE MANUAL

MODEL 400 VIBRATORY HAMMER WITH
MODEL 800 POWER UNIT

7032 So. 196th - Kent, WA. 98032 - (206) 872-0141 / Fax (206) 872-8710

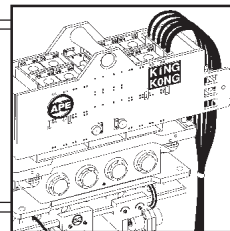

V. MAINTENANCE (Continued...)

V-3. Maintenance and Adjustments. (75 Hours)

Change the oil in vibrator gearbox. Remove the drain plug from bottom of gearbox and drain the oil into a bucket. Check oil for any metal shavings. Replace oil in gearbox by adding 25 gallons of standard weight oil. Mobil Gear 626.

Clean the gearbox breathers each time the oil is changed. Replace the breathers if necessary.

V-4. Maintenance and Adjustments. (Eccentric Bearings)

The Eccentric Bearings should be checked and/or replaced after every 5000 hours of operation.

V-5. Maintenance and Adjustments in Severe Conditions.

When average temperature is above (80 deg. F) or below (-1 deg. F) reduce servicing intervals to one half of those specified above.

When operating in the presence of dust or sand, reduce servicing intervals to one-third of those specified.

During stand-by or inactive periods, the servicing intervals may be reduced to one-half. The unit should be run every 30 days or less to keep internal parts lubricated.

V-6A. Lubrication - Vibratory Gearbox.

The Gearbox oil should be changed weekly or when black or milky. Mobil Gear 626 or equal is the preferred oil. Just ask your oil supplier for an equivalent type of oil. The gearbox requires 25 gallons of oil.

V-6B. Lubrication - Clamp Attachment.

The Clamp Attachment hydraulic oil must be checked and changed on a regular basis. The Clamp Cylinder Plunger should be checked for rust and debris. Lubricate the plunger on a regular basis using the grease zert on the side of the clamp housing .



OPERATION / MAINTENANCE MANUAL

MODEL 400 VIBRATORY HAMMER WITH
MODEL 800 POWER UNIT

7032 So. 196th - Kent, WA. 98032 - (206) 872-0141 / Fax (206) 872-8710

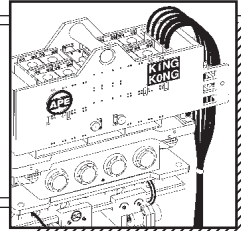

V. MAINTENANCE (Continued...)

V-7A. Power Unit - Filters, Fluid Types, and Capacities. (Table 5-A.)

FILTERS

LOCATION	ENGINE	FILTER TYPE	QUANTITY
Engine Oil:	CAT Engines	CAT 1 R0716	2 each
Engine Fuel:	CAT Engines	CAT 1 R0712	1 each
Air Filter:	CAT Engines	CAT 4N0015	1 each
Hydraulic Oil Filters:	-----	Pall 750OSDS8H	2 each
Hand Pump Filter:	-----	Fairey Arlon FA35-10	1 each

ENGINE OIL TYPES AND CAPACITIES

LOCATION	ENGINE	OIL TYPE	CAPACITY
Hydraulic Oil-Main:	-----	Mobil EAL 224 Veg.	300 gallons
Hyd Oil-Reserve:	-----	Mobil EAL 224 Veg.	55 gallons
Engine Oil:	CAT Engines	CAT 15W40	48 quarts
Engine Water:	-----	50/50 Water/Gycol	27 gallons
Fan Drive:	-----	Multi-Purpose Grease	
Governor Control:	-----	Multi-Purpose Grease	
GearBox:	-----	90W or Synthetic Model 803	

See small sight glass in center of gearbox between hydraulic motors. Oil should be filled to this level. Change every six months.



OPERATION / MAINTENANCE MANUAL

MODEL 400 VIBRATORY HAMMER WITH
MODEL 800 POWER UNIT

7032 So. 196th - Kent, WA. 98032 - (206) 872-0141 / Fax (206) 872-8710

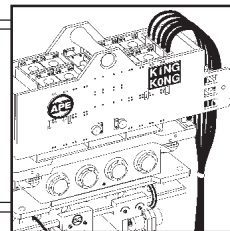

V. MAINTENANCE (Continued...)

V7-B. Power Unit - Hydraulic Fluid.

When adding or changing hydraulic fluid APE uses only Mobil 224 Hydraulic Vegetable oil which is non-toxic and will not harm oil or water and is biodegradable. Consult your local oil supplier for recommendations on mixing hydraulic oils. Change hydraulic oil if it looks milky. This includes all hydraulic lines leading to and from the vibro. Milky oil indicates that water is in the oil.

V7-C. Power Unit - Draining and Filling Hydraulic Fluid Tank

1. Remove plug located on bottom of tank
2. Refill by manually pumping with hand crank.
3. Prime both the clamp and the main pump before restarting.
4. Take extreme caution that no dirt or other unwanted particles enters the system.

V7-D. Power Unit - Cleaning Hydraulic Tank Suction Filter. (No suction on 1993 and newer)

1. Located inside the hydraulic tank or reservoir, is a suction filter.
2. Drain tank.
3. Remove side cover.
4. Reach into tank and unscrew filter from pipe fitting.
5. Clean with solvent and re-install. If damaged then replace.
6. Re-install filter.
7. Re-install tank cover.
8. Add new oil to tank.
9. Prime pumps.



OPERATION / MAINTENANCE MANUAL

MODEL 400 VIBRATORY HAMMER WITH
MODEL 800 POWER UNIT

7032 So. 196th - Kent, WA. 98032 - (206) 872-0141 / Fax (206) 872-8710

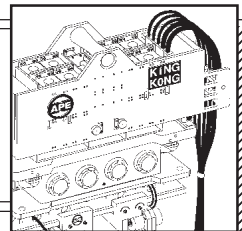

V. MAINTENANCE (Continued...)

V-7E. Power Unit - Changing Hydraulic Return Filter Element.

The hydraulic return filter is mounted on the hydraulic tank inside the power unit. It is mounted high on the tank so that when the filter element is removed the oil will not drain from the hydraulic tank. The filter has a manual pop-up type indicator to tell when the filter is dirty. The pop-up indicator turns red when it is dirty.

V-7F. Power Unit - Steps to Remove the Element.

1. Shut down power unit by turning off the diesel engine.
2. Place warning tag on control panel so that no one mistakenly starts the unit while filters are being changed.
3. Clean area around filter so that when it is removed there is no chance of introducing dirt into the hydraulic system.
4. Using a filter wrench, turn the filter counter clockwise and spin the filter off the filter housing.
5. Install new clean filter making sure the o-ring is in place.
6. Depress filter indicator to re-set to "clean position".



OPERATION / MAINTENANCE MANUAL

MODEL 400 VIBRATORY HAMMER WITH MODEL 800 POWER UNIT

7032 So. 196th - Kent, WA. 98032 - (206) 872-0141 / Fax (206) 872-8710

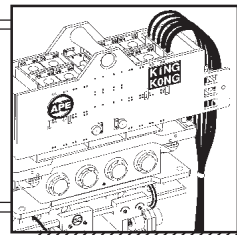

V. MAINTENANCE (Continued...)

V-8. Hydraulic Motor - Installation and Start-Up. - Figure 5A.

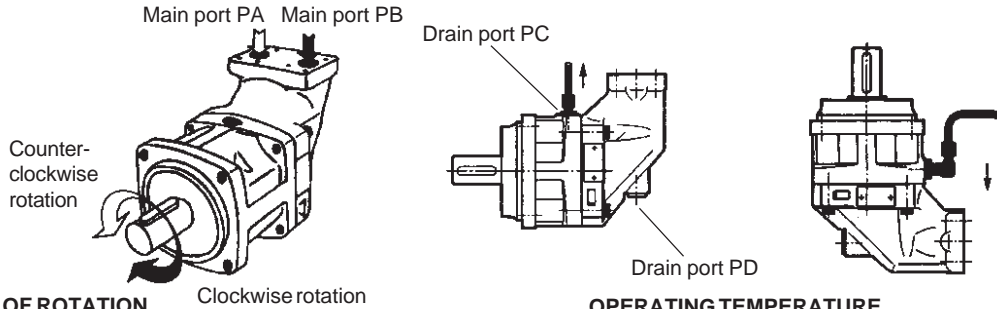

DIRECTION OF ROTATION

The F12 motor is bi-directional. The picture shows direction of flow vs. shaft rotation. When fluid enters through port **PB** (black arrow) the motor turns counter clockwise, and when port **PA** is pressurized (open arrow) the shaft turns counter clockwise.

The F12 pump rotates clockwise or counter clockwise. The ordering code shows the direction of rotation.

FILTRATION

To obtain maximum motor service life, the fluid cleanliness should be checked to meet ISO code 18/13 or better (ISO 4406). A10 um (absolute) filter is recommended.

REQUIRED INLET PRESSURE

The motor sometimes operates as a pump (e.g. when it is used in a propel transmission and the vehicle is going downhill). The motor inlet port must then be supplied with sufficient fluid pressure, or increased noise and deteriorating performance may otherwise be experienced.

CASE PRESSURE

The table shows the highest recommended case pressure (F12 shaft seal type **H**) as a function of shaft speed. To obtain the longest seal life, the case pressure should be limited to 50% or less of the figures shown.

NOTE: Contact VOAC Hydraulics for information on other shaft seals.

Motor designation	Motor case pressure [bar] vs. shaft speed [rpm]				
	1500	3000	4000	5000	6000
F12-30	14.0	7.0	5.5	4.5	3.5
F12-40	12.0	6.0	4.5	3.5	
F12-60	12.0	6.0	4.5	3.5	
F12-80	10.0	5.0	4.0		
F12-110					

CASE DRAIN CONNECTIONS

There are two drain ports (**PC** and **PD**). The uppermost drain port should be utilized. In mounting positions such as 'shaft up', a drain line loop can be formed to provide bearing lubrication and cooling. Preferably, the drain line should be connected directly to the tank to avoid excessively high case pressure.

NOTE: When the motor is operating, the case must be filled with fluid to at least 50%.

OPERATING TEMPERATURE

The following temperatures should not exceed (type **H** seal):

System fluid: 80deg. C
Drain fluid: 100deg. C

Type **V** ('Viton') shaft seals can be used to 115deg. C.

Continuous operation may require case flushing in order to meet the above viscosity and temperature limitations. The table shows operating speeds, above which flushing is usually required, as well as suggested flow through the case.

Motor designation	Speed [rpm]	Flow [l/min]
F12-30	3500	4-8
F12-40	3000	5-10
F12-60	3000	7-14
F12-80	2500	8-16
F12-110	2300	9-18

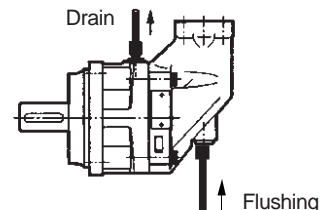

BEFORE START-UP

Make sure the motor case as well as the entire hydraulic system is filled with a recommended fluid. The internal leakage, especially at low operating pressures, is not sufficient to provide lubrication at start-up.

HYDRAULIC FLUIDS

Ratings and performance data for series F12 are based on operating with good quality, contamination-free petroleum-based fluids, Hydraulic fluids type HLP (DIN 51524), automatic transmission fluids type A, or API CD engine oils can be used.

At operating temperature, the viscosity (of the drain fluid) should normally be kept above 8 mm²/s (cSt). At start-up, the viscosity should not exceed 1000 mm²/s.

Fire resistant fluids, when used under modified operating conditions, and synthetic fluids are also suitable. Contact VOAC Hydraulics for further information.

OPERATION / MAINTENANCE MANUAL

MODEL 400 VIBRATORY HAMMER WITH MODEL 800 POWER UNIT

7032 So. 196th - Kent, WA. 98032 - (206) 872-0141 / Fax (206) 872-8710

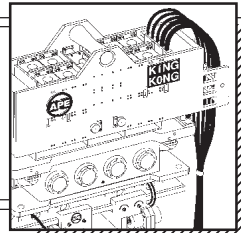

V. MAINTENANCE (Continued...)

V-9. Hydraulic Motor Coupling Assembly.

The APE Hydraulic Motor Coupling Assembly allows the hydraulic fluid to flow between the rifle bored top plate of the vibro gearbox and the hydraulic motors. The following steps should be followed when removing and installing the hydraulic motors or if disassembly is required for maintenance of the coupling assembly:

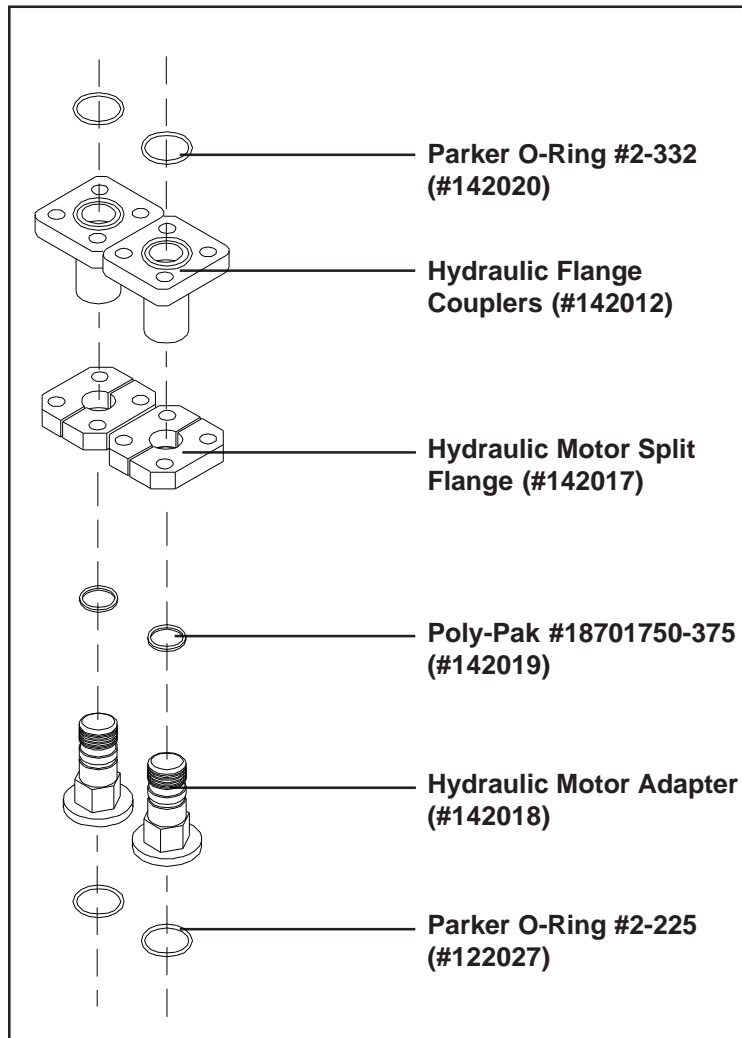

Coupling Removal and Re-assembly:

1. Remove the bolts holding the "Split Flange" to top of the motor.
2. Loosen the 4 bolts which connect the "Hydraulic Flange Couplers" to the bottom of the gearbox top plate.
3. Screw the "Hydraulic Flange Couplers" and the "Hydraulic Motor Adapters" together (This will decrease the overall size of the assembly and allow easier removal of the components).
4. Watch for oil flowing out from the openings on the under side of the top plate. Insert a clean rag into the openings to block the oil flow and to prevent debris from entering the opening and contaminating the hydraulic oil.
5. Reverse the procedure for re-assembly. At assembly, make sure the hydraulic motor is parallel to the top plate by verifying both sides with a tape measure. If necessary, loosen the 4 bolts holding the motor to the gearbox face and shift the motor until the top plate and motor machined face are parallel.

Figure 5-B. Hydraulic Motor Coupling Assembly.



OPERATION / MAINTENANCE MANUAL

MODEL 400 VIBRATORY HAMMER WITH
MODEL 800 POWER UNIT

7032 So. 196th - Kent, WA. 98032 - (206) 872-0141 / Fax (206) 872-8710

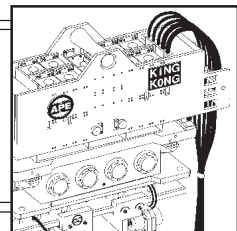

VI. TROUBLE-SHOOTING

The following table lists some possible problems, causes and solutions. If a serious problem should occur, contact the factory for additional service information.

Table 6-A. Vibro Trouble-Shooting Index

ITEM	PROBLEM	ITEM	PROBLEM
1.	Oil Blowing Out Between Gear box and Hydraulic Motor.	6.	Vibrator Won't Start When Start Button is Engaged.
2.	Vibro Gearbox is Too Hot.	7.	Clamp Won't Open When Clamp Open Switch is Engaged.
3.	Excess Oil in the Gearbox.	8.	Vibro Won't Come Up to Normal Operating Speed.
4.	Oil Blowing Out From Pop-Off Valve.	9.	Vibro Won't Stop When Stop Button is Engaged.
5.	Opening and Closing Clamp Jaws Seems Spongy or Slow.		

Possible Cause

Remedy

1. Oil Blowing Out Between Gearbox and Hydraulic Motor.

The breather may be plugged or damaged.

Remove the breather and clean it. If the breather is damaged replace it.

O-rings may not be sealing properly

Check the o-rings between the gearbox top plate and the motor. Clean the seal areas and replace the o-rings if needed.

2. Vibro Gearbox is Too Hot.

Oil level may be too high.

Make sure the gearbox is level. Remove the oil over fill plug (located on the gearbox next to the sight gage). If oil flows out, the oil level is too high and must be lowered.

Oil may be too dirty.

Look at oil in the sight gage. If the oil is black or milky it must be replaced. If you are still not sure, remove the case drain plug and check the oil.

3. Excess Oil in the Gearbox.

The seal between the gearbox and the hydraulic motor may be bad and is allowing oil to flow directly into the gearbox.

Remove the motor from the face of the gearbox. Check and clean the seal area, replace the seal if it looks bad.

4. Oil Blowing out Pop-Off Valve.

Blocked flow in case drain line.

Check case drain line to see if it is pinched.

Check case drain line for proper connection tightness.

Valve may be bad.

Remove and check the valve. Replace the valve if needed.

One or both motors may be damaged.

Remove the motors and have them checked for damage. Replace if needed.



OPERATION / MAINTENANCE MANUAL

MODEL 400 VIBRATORY HAMMER WITH
MODEL 800 POWER UNIT

7032 So. 196th - Kent, WA. 98032 - (206) 872-0141 / Fax (206) 872-8710

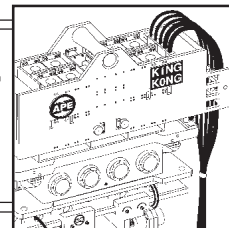

VI. TROUBLE-SHOOTING (Continued...)

Possible Cause

Remedy

5. Opening and Closing Clamp Jaws Seems Spongy or Slow.

The plunger shaft may not be properly lubricated or may need cleaning.

Remove the movable jaw from the clamp. Inspect the plunger shaft and check for lubrication or debris build up. Clean the shaft if needed and then lubricate using the grease zert on the clamp body.

The clamp hoses may have air in them and may need bleeding.

Follow the procedures listed in this manual (page 4-3, Section IV-5.) for bleeding the clamp attachment hydraulic hoses.

6. Vibrator Won't Start When Start Button is Engaged.

Diesel engine is not running.

Start diesel engine.

Start relay contacts may not be closing.

Press and hold the Start Button on the pendant. If vibro starts, replace Start Relay.

Hoses may be connected improperly.

Check hoses and make connection corrections if required.

One or both hydraulic motors may not be operating properly.

Remove one hydraulic motor from the vibro. Leave the hoses connected. Run the power unit engine at approx. 1200 rpm. and press the start button. If motor runs, re-attach it to the vibro and perform the same test with the other motor. If one of the motors does not run, it must be replaced.

Vibro gearbox may be frozen up.

If motors are working fine and the drive pressure appears normal, then the vibro gearbox may be frozen and in need of repair.

Drive pressure is too low.

Manually close start valve at the drive manifold. If vibro will not start, replace the start valve. If vibro still will not start, replace the drive pump.

7. Clamp Won't Open When Clamp Open Switch is Engaged.

Vibrator is running.

The clamp won't open while the vibro is in operation. To open the clamp, stop the vibro.

Diesel engine may not be running.

Start the power unit engine and allow clamp pressure to build.

There may be an electrical failure.

Check for the following:
- Defective clamp switch.
- Broken or loose wire in the pendant or pendant cable.
- Defective OPEN solenoid.
- Broken or loose wire between main power switch and START relay.
- Defective or sticking clamp timing delay relay.
- Broken or loose wire between main power switch and amphenol connector.

The clamp pump may be defective.

Check clamp pump for slipping belts and tighten if required. If clamp won't open, replace clamp check valves. If clamp still won't open, replace the clamp pump.



OPERATION / MAINTENANCE MANUAL

MODEL 400 VIBRATORY HAMMER WITH
MODEL 800 POWER UNIT

7032 So. 196th - Kent, WA. 98032 - (206) 872-0141 / Fax (206) 872-8710

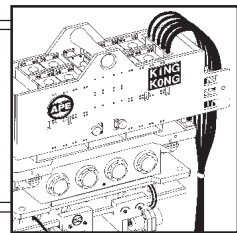

VI. TROUBLE-SHOOTING (Continued...)

Possible Cause

Remedy

8. Vibro Won't Come Up to Normal Operating Speed.

Defective hydraulic motor or drive pump.

If vibration frequency has been verified lower than normal, Replace the hydraulic motors one at a time to see if performance improves. If vibro still operates below normal speed, replace drive motor pump.

9. Vibro Won't Stop When Stop Button is Engaged.

There may be an electrical failure.

Check for the following:

- Defective STOP button.
- Broken or loose wire in the pendant or pendant cable.
- Defective START relay.
- Defective motor START valve.

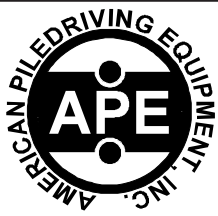

OPERATION / MAINTENANCE MANUAL

MODEL 400 VIBRATORY HAMMER WITH MODEL 800 POWER UNIT

7032 So. 196th - Kent, WA. 98032 - (206) 872-0141 / Fax (206) 872-8710

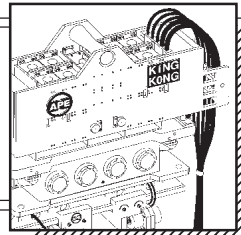

VI. HYDRAULIC CIRCUITRY - MODEL 800

The model 800 power unit, consists of a bi-directional 240 gpm/5000 psi hydraulic circuit to drive the King Kong Vibro or other auxiliaries, a 10 gpm/5000 psi circuit to operate the Vibro clamp, a 75 gpm internal cooling circuit, and all the hydraulic accessories to support these systems.

VII-1A. Drive Circuit.

The drive circuit has four pumps (01) which produce 240 gpm flow when the diesel engine is at full speed. They take suction from the reservoir via suction strainers (17) through isolation valves (15). The drive manifold (29) use's cartridge valves to provide smooth direction changes. With the Vibro control in NEUTRAL, all pump flow returns to tank via the open cartridge valves (7,37). Motor direction is changed by opening and closing opposite sets of cartridge valves (7a-7d). The proportional relief valve circuit (32,37,39,41) ensure smooth shifts. When the drive control is taken to FORWARD, the pilot control valve (11) shifts, porting pilot oil to the top of cartridge valves 7a and 7c, thereby closing them. Oil then flows from the pumps (01) through cartridge valve 7b and out to the Vibro via the quick disconnect (09). Return oil comes through the quick disconnect (09), to cartridge valve 7d. It returns to the reservoir via the return live filters (14). When the drive control is taken to REVERSE, the pilot control valve is shifted in the opposite direction, and cartridge valves 7b and 7c are held closed. System flow is as above except that the oil flows out through 7a and returns through 7d. The proportional relief circuit smoothes the direction changes by ramping system pressure up and down, and only allowing the cartridge valves to shift when the system pressure is at zero (shown by system pressure gauge 28c). When the controls are in NEUTRAL, the relief circuit control valve (39) is de-energized and cartridge valve (37) is open to tank. When the controls are taken to either FORWARD or REVERSE direction, the relief circuit control valve (39) is energized (connecting the manual relief valve (41) to tank), and the proportional relief valve (32) is energized. The proportional relief valve (32) ramps up to 4800 psi, which brings system pressure up to 4800 psi. When the directional controls are taken back to NEUTRAL the opposite occurs. The proportional relief (32) ramps down to zero psi (bringing system pressure to zero), the control valve (39) is de-energized, and then the pilot control valve (11) is de-energized, shifting the cartridge valves.

VII-1B. Clamp Circuit.

The clamp pump (03) takes suction from the reservoir via a suction strainer (18) and an isolation valve (15). The clamp manifold (24) provides direction control (27) and over pressure relief (25). With the clamp control in NEUTRAL, pump output returns to tank. Turning the clamp switch to CLOSE energizes the clamp control valve (27). Hydraulic fluid is directed to the head end of the cylinder and the clamp closes. Hydraulic pressure builds (28a) when the clamp is fully closed. At 4800 psi the pressure switch (46) opens and the control valve (27) de-energizes. When pressure drops to 4500 psi, the pressure switch (46) closes, and the clamp control valve is re-energized to bring pressure back up to 4800 psi. Turning the clamp switch to OPEN, energizes the clamp control valve (27). Hydraulic fluid is directed to the rod side of the cylinder. The pressure in the open line opens the clamp check valve (26). The clamp opens. Pressure is limited to 4800 psi by the clamp relief valve (25).



OPERATION / MAINTENANCE MANUAL

MODEL 400 VIBRATORY HAMMER WITH MODEL 800 POWER UNIT

7032 So. 196th - Kent, WA. 98032 - (206) 872-0141 / Fax (206) 872-8710

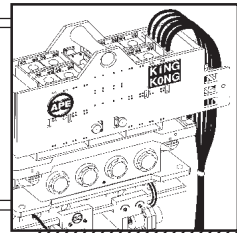

VII-1C. Oil Cooler.

A dedicated cooling loop is on line whenever the diesel engine is running. Pumps 4 and 5 take suction from the reservoir via suction strainers (17) and isolation valves (15). The oil is pumped through the heat exchanger (10) mounted on the engine radiator. 65 psi is maintained in the circuit with a check valve bypass (5).

VII-1D. Manual Pump.

A manual pump (12) provides a means to put new oil into the reservoir. All oil is pumped first into the upper spare hydraulic reservoir. The lower main tank is filled by turning a quarter turn valve that allows the oil from the spare upper tank to gravity feed into the lower main tank.

VII-1E. Hydraulic Oil Temperature.

A temperature gage #15, indicates hydraulic oil temperature. The sending unit is mounted on the outboard side of the oil cooler or heat exchanger just behind the control panel and accessed through the swinging front door.

VII-1F. Hydraulic Components. - Table 7-A.

ITEM	QTY	DESCRIPTION	PART NUMBER	MFG.	APE, P/N
1	4	Pump	#F12-110-LS-SH-S	VOLVO	#
2	1	Pump, Drive 4SAE D Pads	#804F 1:1	HUB CITY	#
3	1	Pump, Fixed Piston	#F11-019-LU-SH-S	VOLVO	#
4	1	Pump, Fixed Vane	#25V-21A-11C22L	VICKERS	#
5	1	Valve, Check 2"	#CV-14P-65	LHA	#
6	1	Pump	#25VTBS-21A2-297C-A-22L	VICKERS	#
7	4	Valve, Insert, 50mm DIN	#CV1-50-D20-2-M-10	VICKERS	#
8	1	Adapter Plate	#DGAM-3-01-10	VICKERS	#
9	2	Coupling, Disconnect Female/Male	#5TV-CN-32	HYD. INC.	#
10	1	Cooler, Air/Oil	DB#05371	DUNHAM BUSH	#
11	1	Valve, 4W 3P Float, Sol.	#DG4V-3S-6C-M-U-H5-60	VICKERS	#
12	1	Pump, Hand Operated	#PA-414	BLACKMER	#
13	1	Valve, Ball	#70-106	APOLLO	#
14	2	Filter, Return Dual Spin-On	#HH7502B32DSSBPL	PALL	#
15	6	Valve, Rising Stem Gate	#208-2-1/2"	RED & WHITE	#
16	2	Valve, Rising Stem Gate	#208-1"	RED & WHITE	#
17	6	Suction Strainer	#SS-300-3	ZINGA	#
18	1	Suction Strainer	#SS-250-3	ZINGA	#
19	1	Filter, Return Spin-On	#FA35-25-N16-15-A	FAIREY	#
20	1	Gauge, Sight	#G607-04-A-1-1/2"NPT	LUBE	#
21	1	Gauge, Sight	#G607-30-A-1-1/2"NPT	LUBE	#
22	1	Valve, Ball	#70-106	APOLLO	#
23	1	Breather	#BF-16	LENZ	#
24	1	Clamp Manifold	#9200030A	RUCKER	#
25	1	Valve, Relief	#0-811-101-170	BOSCH	#
26	1	Valve, Check	#0-811-020-016	BOSCH	#
27	1	Valve, DIN 4 Way/3 Pos.	#0-811-001-708	BOSCH	#
28	3	Gauge, Pressure	#7718-0-6000-2.5"LLBM-SG	ENFM	#
29	1	Manifold, 800 Drive	#9305009	PMR	#
30	1	Valve, Check	#CXCD-XAN	SUN	#
32	1	Valve, Proportional Relief	#ECG-02-10-30	VICKERS	#
33	1	Amplifier, Plug	#EHH-AMP-702-F-10	VICKERS	#
34	1	Connector, DIN	#977896	VICKERS	#
37	1	Valve, Insert 50mm DIN	#CVI-50-D11-2-H-10-08	VICKERS	#
38	4	Cover	#CVS-50-N-S2-10-08	VICKERS	#
39	1	Valve, 4W 2P Single Sol.	#DG4V-3S-2A-M-U-H5-60	VICKERS	#
40	1	Valve, Cover 50mm DIN	#CVCS-50-N-S2-10-08	VICKERS	#
41	1	Valve, Relief Sandwich	#RPEC-FCN-FBP	SUN	#
42	1	Coupling, Disconnect	#5100-S5-12B	PARKER	#
43	1	Coupling, Disconnect	#6-S30-3	IMPERIAL	#
44	1	Assembly, Pile Driver	#N/A	APE	#
45	1	Cylinder, Clamp	#N/A	APE	#
46	1	Switch, Pressure	#DE4-SBHS-8K	OILDYNE	#



OPERATION / MAINTENANCE MANUAL

MODEL 400 VIBRATORY HAMMER WITH
MODEL 800 POWER UNIT

7032 So. 196th - Kent, WA. 98032 - (206) 872-0141 / Fax (206) 872-8710

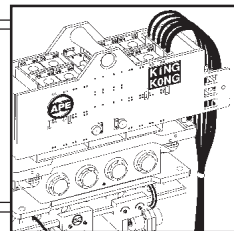

VII. MODEL 800 POWER UNIT (Continued...)

VII-2. Electrical Circuitry.

The following are descriptions of components that make up the Electric Circuitry of the APE Model 800 Power Unit.

VII-2A. Diesel Engine.

The HYDRAULIC POWER UNIT is powered by a 4 stroke compression ignition diesel engine. Two 12 volt (4D) batteries provide 24 volts for starting the engine and running the electrical controls.

VII-2B. Controls: (Understanding How They Work).

1. Engine Control Switch "OFF/ON/START"

The ENGINE CONTROL SWITCH is used to start and stop the diesel engine. Turning it to "ON" turns on all power to the panel. Turning to START energizes the engine starter solenoid which activates the starter motor which turns the diesel engine flywheel and causes the engine crankshaft to turn which, through various mechanical actions, acts on the fuel pump. As the engine turns, the fuel pump injects fuel into the combustion chamber of each piston cylinder at timed intervals and as the engine continues to crank, fuel and air is compressed in the combustion chamber by each piston as it comes up on the compression stroke. As the pistons compress fuel and air, the fuel and air mix into a combined gas that ignites under pressure when each piston nears the top of its stroke the gas explodes, forcing the piston downward and converts thrust into torque via a connecting rod pinned to the piston and mounted to a crankshaft. When the piston reaches the bottom of the cylinder, it begins its upward travel and an exhaust valve at the top of the cylinder opens, forcing unburned gases out. When the piston reaches the top, the exhaust valve closes and an intake valve opens as the piston travels back downward. The piston sucks new air into the combustion chamber while the fuel injector adds fuel. These four cycles of intake, compression, ignition and exhaust continue until the engine fuel delivery is cut off.

Once the engine is rotating on its own power, the switch is released. The switch returns to the "ON" position because it is spring loaded in that direction. To turn the engine off, the switch is turned to the "OFF" position, which sends a grounded signal that activates the ENGINE SAFETY SHUT DOWN SWITCH which then cuts power to the fuel solenoid and stops the engine.

2. "LOCAL/REMOTE" Switch.

The LOCAL/REMOTE SWITCH is used to allow the operator to control the power unit from either the CONTROL PANEL or the REMOTE HAND HELD PENDANT. The LOCAL / REMOTE SWITCH must be in the LOCAL position to start the engine.



OPERATION / MAINTENANCE MANUAL

MODEL 400 VIBRATORY HAMMER WITH
MODEL 800 POWER UNIT

7032 So. 196th - Kent, WA. 98032 - (206) 872-0141 / Fax (206) 872-8710

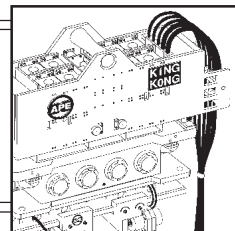

VII. MODEL 800 POWER UNIT (Continued...)

VII-2B. Controls: (Understanding How They Work). (Continued...)

3. Clamp "OPEN/OFF/CLOSE" Switch.

The CLAMP OPEN/OFF/CLOSE SWITCH is used to control the direction of the hydraulic flow coming from the clamp pump. When the engine is running and the switch is in the "OFF" position, all clamp PUMP oil is returned to the tank. Turning the CLAMP CLOSE/OFF/OPEN SWITCH to the close position energizes the clamp close solenoid, which can be observed with the lighted connector. When the close solenoid energizes, the clamp close valve closes sending hydraulic oil to the closed side of the clamp cylinder. When the pressure reaches 4000 psi, the CLAMP PRESSURE SWITCH (located on the clamp manifold) opens, de-energizing the closed solenoid and lighting a lamp in the CLAMP OPEN / OFF / CLOSE SWITCH and the green lamp on the remote HAND HELD PENDANT. If the pressure drops below 3800 psi, the CLAMP PRESSURE SWITCH closes allowing the close solenoid to recharge the clamp close hydraulic circuit. Note: If the light on the solenoid stays on and the green light on the pendant fails to come on then the pressure switch may be faulty. Do not operate the machine if you can see the clamp closed solenoid light on all the time. (Note: the clamp closed solenoid light is located on the solenoid.) It should go off as soon as the jaws close and the pressure rises above 3800 psi. When jaws are closed properly, the green light will glow on the remote pendant, or if operating from the panel, the green light is built into the switch. When the diesel engine is running, Turning the clamp switch to "OPEN" energizes the open solenoid and directs oil to the open side of the clamp cylinder and the jaws open.

4. Drive "FORWARD/REVERSE" Switch.

The DRIVE FORWARD/REVERSE SWITCH is used to control the hydraulic motors on the vibrator or for supplying forward and reverse direction on a drill. With the engine running and the DRIVE FORWARD / REVERSE SWITCH in the forward position, the forward drive solenoid energizes, which can be observed with the lighted connector. With the forward drive solenoid energized, the forward valve opens, sending hydraulic fluid to the hydraulic motors, and the motors rotate. With the engine running and DRIVE FORWARD/REVERSE SWITCH in the reverse position, the reverse drive solenoid energizes, which can be observed with the lighted connector. With the reverse drive solenoid energized, the reverse valve sends oil to the vibrator motors but the motors do not rotate because all oil flow is directed around the motors via the ANTI-CAVITATION CHECK VALVE located on the vibro suppressor housing and plumbed into the hoses leading to and from the hydraulic motors. Therefore, the vibrator runs in the forward direction only, and this direction is used for driving or pulling all piles. The reverse direction is used when the power unit is supplying oil to a drill or other attachment or when flushing the oil during initial startup.

5. "SYSTEM OK" Light.

The "SYSTEM OK" Light is lighted when the engine is running and all systems are normal.

6. "SPARE" Light.



OPERATION / MAINTENANCE MANUAL

MODEL 400 VIBRATORY HAMMER WITH
MODEL 800 POWER UNIT

7032 So. 196th - Kent, WA. 98032 - (206) 872-0141 / Fax (206) 872-8710

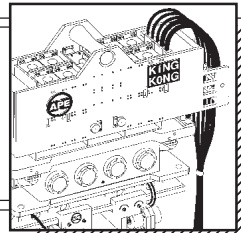

VII. MODEL 800 POWER UNIT (Continued...)

VII-2B. Controls: (Understanding How They Work). (Continued...)

7. Throttle "RAISE/OFF/LOWER" Switch.

This switch is used to throttle the engine up or down. This switch turns a small motor hooked to the engine throttle. APE power units with CAT engines use a system supplied by CAT. The CAT engine throttle requires two small relays mounted inside the control panel. The APE units with Cummins engines do not have relays and are wired directly to a Murphy worm drive throttle box mounted on the engine.

8. "OIL PRESSURE" Gauge:

An electric "OIL PRESSURE" Gauge is provided to monitor engine oil pressure. The CAT oil pressure gauge is wired to an oil pressure sender that forces the gauge to read zero pressure when the power is turned on. The CAT sender is a variable resistor that is normally grounded and slowly decreases the grounded voltage as pressure is delivered to it. As the voltage decreases, the pressure gauge reading increases. To test the sender, disconnect the wire leading to it and place one OHM meter lead on the sender terminal and the other lead on the engine. It should show maximum resistance. If not, replace it.

9. "ENGINE OIL PRESSURE" Switch:

A small ENGINE OIL PRESSURE Switch mounted on the diesel engine is designed to ground out when pressure drops below 40 psi. The switch is designed to be normally open when under pressure. When pressure is lost, the switch closes sending a grounded signal that activates the safety shut down switch on the panel which cuts power to the fuel solenoid and shuts down the engine.

10. "WATER TEMPERATURE" Gauge:

An electric "WATER TEMPERATURE" Gauge is provided to monitor engine water temperature.



OPERATION / MAINTENANCE MANUAL

MODEL 400 VIBRATORY HAMMER WITH MODEL 800 POWER UNIT

7032 So. 196th - Kent, WA. 98032 - (206) 872-0141 / Fax (206) 872-8710

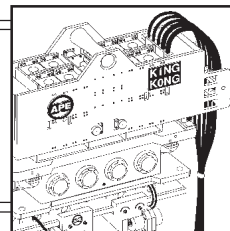

VII. MODEL 800 POWER UNIT (Continued...)

VII-2B. Controls: (Understanding How They Work). (Continued...)

12. "WATER TEMPERATURE" Switch:

A water temperature switch is mounted on the engine. It is a normally "open" switch. If the water temperature increases to a level that may damage the engine, the switch closes, sending a grounded signal that activates the "ENGINE SAFETY SHUTDOWN" Switch located on the panel. This switch can give a faulty signal and cause the engine to shut down even when water temperature is normal. To test the switch, disconnect the wire leading to it. Test the switch using an OHM meter by placing one OHM lead to the switch terminal and one to the grounded engine. You should not see a reading on the OHM meter (provided the water temperature is below 207 degrees F.). If the OHM meter shows resistance then replace the switch.

13. "FUEL PRESSURE" Gauge:

An electric FUEL PRESSURE Gauge is provided to monitor engine fuel pressure. An electrical variable resistor mounted on the fuel system sends a signal to the gauge. The sender is designed to send a signal to the panel gauge as pressure increases which increases the gauge reading.

14. "TACHOMETER"

A "TACHOMETER" is provided to monitor the engine speed for optimum operation. The tachometer is digital and operates off a magnetic pickup that receives a signal from the flywheel of the engine. Note: If the tachometer seems to be reading wrong, check with a photo tach. Adjustments can be made on the back of the tachometer. Consult factory for proper setting of tach switches.

VII-2C. Preparing The Electrical System For Start-Up.

To start the engine the (CIRCUIT BREAKER) should be in the "ON" position (PUSHED IN AND LOCKED) and the FORWARD/OFF/REVERSE switch both on the panel and on the pendant should be in the off position. The engine will not start if the DRIVE/OFF/FORWARD switch is in the "ON" position. This prevents the operator from accidentally starting the engine and setting the vibrator or drill into motion the moment the engine starts.

VII-2D. Engine Safety Shut-Down Button Switch.

The "ENGINE SAFETY SHUT DOWN BUTTON SWITCH" turns on and off the fuel solenoid that is mounted on top of the engine. The button must be depressed in order to get power to the fuel solenoid and allow the engine to receive fuel to the fuel pump. Three safety switches: (1. Water Temperature, 2. Engine Oil Pressure and 3. Hydraulic oil level) on the power unit are wired into the "ENGINE SAFETY SHUT DOWN BUTTON SWITCH" and will shut the engine off automatically if any of these three switches is closed. (Please see "Engine Safety Shut-Down (Three Causes Of Engine Shut-Down)" in this manual for detailed instructions on how these switches work and read the TROUBLESHOOTING SAFETY SHUT DOWN SWITCHES in this manual to render repairs. It is very simple, please make the effort to read and understand these switches and how they work.)



OPERATION / MAINTENANCE MANUAL

MODEL 400 VIBRATORY HAMMER WITH
MODEL 800 POWER UNIT

7032 So. 196th - Kent, WA. 98032 - (206) 872-0141 / Fax (206) 872-8710

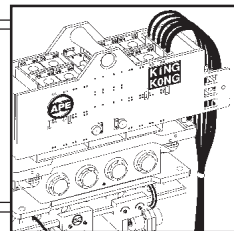

VII. MODEL 800 POWER UNIT (Continued...)

VII-2D. Engine Safety Shut-Down Button Switch. (Continued...)

If the button pops back out the moment you release your finger from the button, then one or more of the three shut down switches is closing and grounding the "ENGINE SAFETY SHUT DOWN SWITCH". This will happen for the described in the following section of this manual.

VII-2E. Engine Safety Shut-Down (Three Causes Of Engine Shut-Down).

1. No Oil Pressure:

The engine oil pressure is used to open and hold open a small pressure switch mounted on the diesel engine. The engine oil pressure holds open the oil pressure switch as long as the engine is running and there is proper engine oil pressure. If the oil pressure drops, (NO OIL PRESSURE COULD RESULT IN A DESTROYED ENGINE) the switch closes and grounds the ENGINE SAFETY SHUT DOWN SWITCH located on the control panel which activates and cuts power to the fuel solenoid and shuts the engine down, saving the engine from possible damage due to lack of oil. Sometimes the oil pressure switch fails and sends a grounded signal to the "ENGINE SAFETY SHUT DOWN SWITCH" even when the oil pressure is fine. Please read the section titled "TROUBLESHOOTING: ENGINE OIL PRESSURE SWITCH" in this manual if you think this may have happened.

2. High Engine Coolant Temperature:

The engine coolant or engine water temperature is controlled by a temperature switch. This switch, located on the front of the engine, is normally open when the coolant temperature is normal. If the engine coolant becomes too hot the switch closes and sends a grounded signal which activates the "ENGINE SAFETY SHUT DOWN SWITCH" located on the panel. When this happens, power is cut to the fuel solenoid and the engine stops which prevents the engine from overheating and destroying itself. Sometimes this switch fails to work properly and shuts the engine down even when the water temperature is fine. Please read the section titled "TROUBLESHOOTING: ENGINE WATER TEMPERATURE SWITCH" in this manual if you think this may have happened.

3. Low Hydraulic Oil Temperature:

The hydraulic oil level in the tank is controlled by an oil level switch that is normally open when oil is in the tank at an acceptable level for operation. If the hydraulic oil level drops below the required level, the switch will close and send a grounded signal activates the "ENGINE SAFETY SHUT DOWN SWITCH" located on the panel. When this happens, power is cut to the fuel solenoid and the engine stops which prevents the hydraulic pumps from destruction due to lack of hydraulic oil. Some times this switch fails to work properly and shuts the engine down even when the oil level in the tank is normal. Please read the section titled "TROUBLESHOOTING: HYDRAULIC OIL LEVEL SWITCH" in this manual if you hink this may have happened.

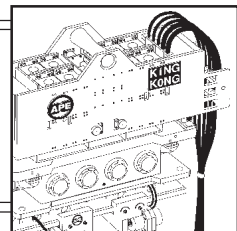

VII. MODEL 800 POWER UNIT (Continued...)

VII-3. Remote Control Pendant.

A "REMOTE HAND HELD CONTROL PENDANT" is provided to allow operation of the power unit at a distance of up to 50 feet (15 meters) and can be extended using 50 foot extension cables. The "REMOTE HAND HELD CONTROL PENDANT" is connected to the control panel via a multiconnector plug.

This remote can be used to check all the electrical control valves by simply disconnecting the wire to the engine oil pressure switch and pushing in the safety shut down button and then turning on the star switch to the on position. Once this is done, you can walk over to the valves while holding the pendant in your hand. As you switch the valves you can see the lighted connectors go on and off on the top of the four solenoids: clamp open, close & drive forward and reverse.

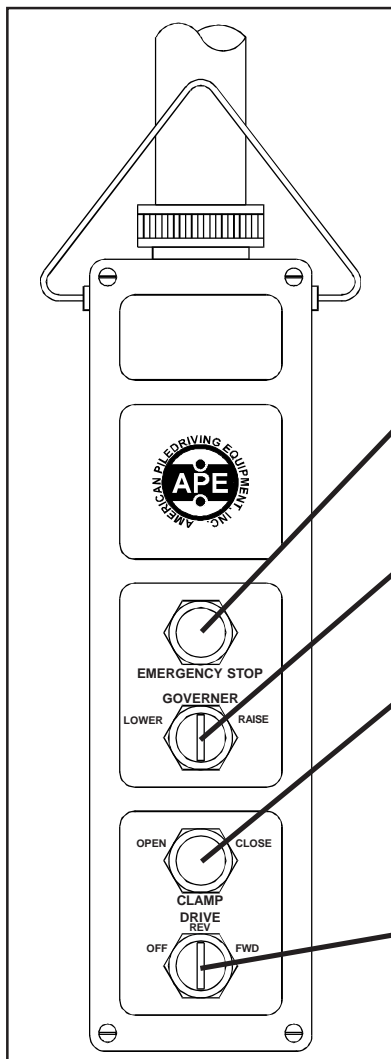

ENGINE EMERGENCY SHUTDOWN SWITCH:
Press and hold to shut engine off. Do not use to shut engine off at the end of shift. Shut unit off at panel at end of shift. Button is for emergency only.

ENGINE THROTTLE "RAISE/LOWER" RPM:
Three Position Switch. Press and hold button to raise or lower deisel engine rpm.

CLAMP OPEN/CLAMP CLOSE:
Lighted switch. Move to **close** to extend jaw and clamp vibro to pile. Light comes on when clamp is closed and locked. Turn to **open** to retract jaw and release vibro from pile. Switch must remain in **closed** position to hold clamp to pile. Sometimes the light will not come on. It could be burnt out or shorted. Check clamp pressure gauge and make sure it reads at least 3800 psi before vibrating any pile. Contact APE if light is not working.

FORWARD/OFF/REVERSE:
Three position switch. Turn to **forward** to operate vibro. Turn to **off** to stop vibro. Turn to **reverse** when using power unit to run a drill motor. Vibro is not supposed to vibrate in reverse. If it does then switch the two yellow cables labled "drive" and "reverse" located on the other side of the control panel.

Figure 7-A. Remote Control Pendant.

WARNING: Never leave vibro clamped to a pile without the crane line attached. The clamp cylinder could bleed off causing the vibro to drop. Neverhoist a pile in the air without a safety line attached to the pile. Should the clamp close line become damaged and leak, the clamp cylinder could lose pressure and drop the pile.



OPERATION / MAINTENANCE MANUAL

MODEL 400 VIBRATORY HAMMER WITH
MODEL 800 POWER UNIT

7032 So. 196th - Kent, WA. 98032 - (206) 872-0141 / Fax (206) 872-8710

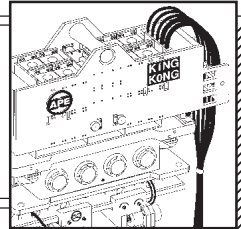

VII. MODEL 800 POWER UNIT (Continued...)

VII-3. Remote Pendant Wiring Diagram.

The following is the pin wiring configuration and the wire colors of the amphenol connectors for the remote control pendant cable.

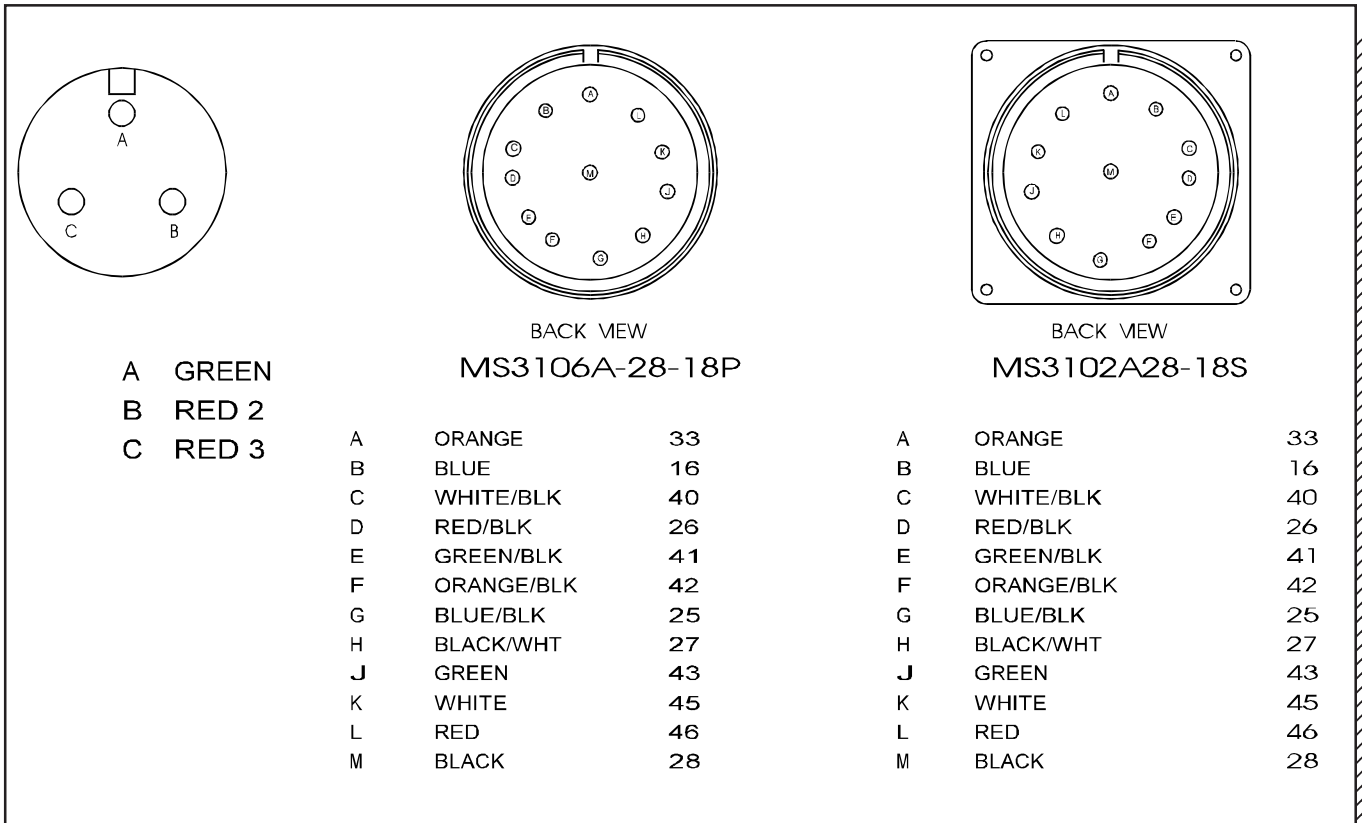

Figure 7-D. Remote Pendant Wiring Diagram.



OPERATION / MAINTENANCE MANUAL

MODEL 400 VIBRATORY HAMMER WITH
MODEL 800 POWER UNIT

7032 So. 196th - Kent, WA. 98032 - (206) 872-0141 / Fax (206) 872-8710

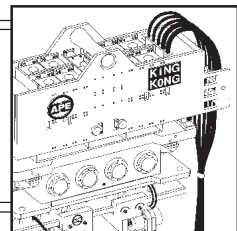

VII. MODEL 800 POWER UNIT (Continued...)

VII-4. Troubleshooting: Power Unit Electrical.

Use the following sections to help determine and solve problems that may arise within the power unit electrical system.

VII-4A. Troubleshooting: Engine Oil Pressure Switch.

The "ENGINE OIL PRESSURE SWITCH" is "open" when the engine is running so if this switch has shut down the engine, then it must be closing. Remove the wire from the switch and see if the engine will now run without the oil pressure switch connected. Make sure you do not have the wire that you just disconnected touching the engine or anything that could ground it. If the engine still shuts down the moment you let go of the "ENGINE SAFETY SHUT DOWN BUTTON SWITCH" then one of the other two safety switches is shutting down the engine. To test the switch, start the engine and use an OHM meter to see if the switch is open by placing one OHM meter lead on the switch terminal and the other OHM lead on the grounded engine. You should not show any resistance. If the engine is not running you should show resistance on the OHM meter because the switch will be closed. Replace switch if necessary.

VII-4B. Troubleshooting: Engine Water Temperature Switch.

The "ENGINE WATER TEMPERATURE SWITCH" is normally "open" and will only close if the water is too hot. If you think the engine has shut down because of a faulty temperature switch then remove the wire from the switch and try to start the engine again. If the engine is not running when you release your finger from the "ENGINE SAFETY SHUT DOWN SWITCH" then you have found your problem, it is the switch. To double check the switch, put one OHM meter lead on the switch and the other on a the grounded engine. OHM meter should show no reading. Replace if necessary.

VII-4C. Troubleshooting: Hydraulic Oil Level Switch.

The "HYDRAULIC OIL LEVEL SWITCH" is normally "open" when there is oil in the tank filled to the proper level. The switch is mechanically attached to a float that is submerged in the hydraulic oil tank. If the oil level drops, so does the float, and the switch will close if the oil level gets too low. It will also close if the oil level is just slightly above the float but the power unit is mounted on the back of a crane that is swinging so fast that the oil level is effected by the washing of the oil in the tank. When the switch closes, it sends a grounded signal that activates the "ENGINE SAFETY SHUT DOWN BUTTON SWITCH" located on the panel which cuts power to the fuel solenoid and shuts the engine down. The fuel solenoid must be energized to allow fuel to get to the fuel pump. If you think the "HYDRAULIC OIL LEVEL SWITCH" may be causing the engine to shut down, disconnect the wire at the float switch located on the hydraulic tank. Try to start the engine. If it runs even after you remove your finger from the "ENGINE SAFETY SHUT DOWN BUTTON SWITCH", then you have located your problem- the float switch is not working. To check, put one lead of the OHM meter on the terminal and the other lead on the ground. The meter should not show a reading. If it does, your oil is too low or the switch is bad. Replace it.



OPERATION / MAINTENANCE MANUAL

MODEL 400 VIBRATORY HAMMER WITH
MODEL 800 POWER UNIT

7032 So. 196th - Kent, WA. 98032 - (206) 872-0141 / Fax (206) 872-8710

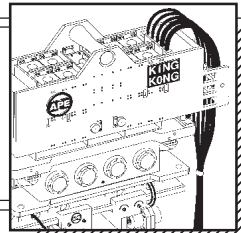

VII. MODEL 800 POWER UNIT (Continued...)

VII-4. Troubleshooting: Power Unit Electrical. (Continued...)

VII-4D. Troubleshooting: Oil Pressure Sending Unit.

An electric "OIL PRESSURE GAUGE" is provided to monitor engine oil pressure. The CAT oil pressure gauge is wired to an oil pressure sender that forces the gauge to read zero pressure when the power is turned on. The CAT sender is a variable resistor that is normally grounded and slowly decreases grounded voltage as pressure is delivered to it. As the voltage decreases, the pressure gauge reading increases. To test the sender, disconnect the wire leading to it and place one OHM meter lead on the sender terminal and the other lead on the engine. It should show maximum resistance. If not, replace it. CAT ONLY.



OPERATION / MAINTENANCE MANUAL

**MODEL 400 VIBRATORY HAMMER WITH
MODEL 800 POWER UNIT**

7032 So. 196th - Kent, WA. 98032 - (206) 872-0141 / Fax (206) 872-8710

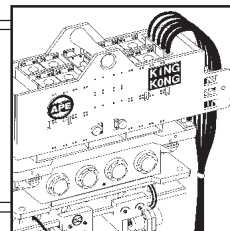

- APPENDIX A -

CAT 3412 Twin Turbo 800 HP Engine

A-1. ENGINE OPERATION INSTRUCTIONS

The following sections are basic instructions for maintenance and operation of the **Model 800 Power Unit Engines**. All maintenance should be performed by qualified personnel who are familiar with the equipment. (Consult the factory for additional information.)

A-1A. PRE-START INSPECTION AND PROCEDURES

1. Make a "walk-around" inspection of the engine and components for the oil, water or fuel leaks and general appearance. Correct minor adjustments before they develop into major repair jobs.
2. Check the crankcase oil level. Maintain the oil level between the ADD and FULL marks on the dipstick. See OIL SPECIFICATIONS for type of oil to use.
3. Check oil level(s) on driven equipment.

WARNING: Check the engine coolant level when the engine is cool. If the engine is warm, steam may spray outward under high pressure and cause personal injury.

4. Check the engine jacket coolant level. Slowly turn the pressure cap until the cap is removed. Maintain coolant level to the base of the fill pipe.
5. Check the fuel supply. Keep fuel tanks full, as partially filled tanks will collect moisture. See the FUEL SPECIFICATIONS for type of fuel.

KEEP THE FUEL SUPPLY CLEAN

6. Open the raw water valve on the engine jacket heat exchanger system (if so equipped). Prime the raw water pump if the raw water system has been drained.
7. Reset shutoff devices. See the topic, ATTACHMENTS, Emergency Shutoff Devices and Alarms. If the engine is equipped with an air safety shutoff control, and was tripped to the shutoff position, reset the latch to the run position.
8. Open the fuel supply valve. If the engine has not run for some time it may be necessary to prime the system. See the topic, PRIMING THE FUEL SYSTEM.
9. Disconnect any battery charger which is not protected against starting motor drain.
10. Disengage the clutch, or open the circuit breaker on a generator set.



OPERATION / MAINTENANCE MANUAL

MODEL 400 VIBRATORY HAMMER WITH
MODEL 800 POWER UNIT

7032 So. 196th - Kent, WA. 98032 - (206) 872-0141 / Fax (206) 872-8710

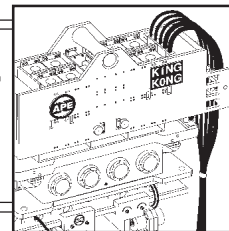

- APPENDIX A -

CAT 3412 Twin Turbo 800 HP Engine

A-1B. STARTING THE ENGINE.

CAUTION: Do not engage the starter when the flywheel is moving.

Electric Starting

1. Move the governor control lever to approximate half engine speed position.
2. Use starting aids if required.
3. Push the START button; or turn the HEAT START switch to the START position, depending upon the control the engine has. Release the control as soon as the engine starts.

For generator sets, place the AUTO-MAN switch in the MAN position to crank the engine. As soon as the engine starts, and the engine speed reaches 600 rpm and oil pressure is approximately 22 psi (1.5 kg /CM²), the starter motor will disconnect from the circuit. (The STOP position is used to stop the diesel engine.)

If the engine fails to start within 10 seconds, move the governor control lever to the fuel off position, then continue to crank for 10 seconds. This will clear the cylinders of unburned fuel.

If the engine fails to start after 30 seconds of cranking, allow the engine to cool for 2 minutes before repeating the starting procedure.

CAUTION: Prolonged cranking at low oil pressure can activate the mechanical safety shut-off. If the reset lever is in the shut-off position, reset the mechanical shut-off control.

CAUTION: NEVER use starting aids when the engine is warm and running.

Air Starting

1. Open and close the bleed valve on the bottom of the air tank to drain condensation and oil carryover.
2. Check the air supply pressure. The air start must have 100 PSI (7 kg/cm²) to operate properly.
3. Keep oil level, in the oiler jar, at least half full. Add oil if necessary.
4. Push the air valve control in to crank the engine. As soon as the engine starts, release the valve.



OPERATION / MAINTENANCE MANUAL

MODEL 400 VIBRATORY HAMMER WITH
MODEL 800 POWER UNIT

7032 So. 196th - Kent, WA. 98032 - (206) 872-0141 / Fax (206) 872-8710

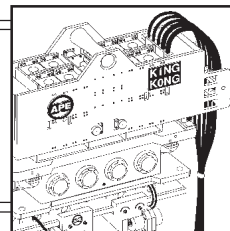

- APPENDIX A - CAT 3412 Twin Turbo 800 HP Engine

A-1. OPERATION INSTRUCTIONS. (Continued...)

A-1C. ENGINE OPERATION.

After the engine starts, and at frequent intervals while the engine is operating, the gauges should be observed. Determine the normal reading for each gauge. Investigate the cause whenever there is a significant change in the reading.

Tachometer

The tachometer indicates engine RPM. The high idle RPM and the full load RPM are stamped on the engine's information plate. The engine can be operated between these two speed limits for long periods of time without shortening engine life. Prolonged operation at high idle with little or no load can cause adverse engine operation.

Engine Oil Pressure

If the gauge reading fluctuates after the load is stable:

1. Remove the load.
2. Reduce engine speed to low idle.
3. Observe the oil level. Maintain the oil level between the ADD and FULL mark on the dipstick. If the reading continues to fluctuate when the oil level is correct, stop engine and call your Caterpillar dealer.

Engine Jacket Water Temperature

The engine should operate within the NORMAL (green) range. If the engine is operating in the (red) range and steam becomes apparent:

1. Reduce the load and engine RPM.
2. Inspect for coolant leaks.
3. Determine if the engine must be shut down immediately; or if the engine can be safely cooled by reducing the load. (See COOLING SPECIFICATION INSTRUCTIONS.)

CAUTION: Do not add cold water to a hot engine: Cracking of engine components may occur. Allow the engine to cool, then add coolant.



OPERATION / MAINTENANCE MANUAL

MODEL 400 VIBRATORY HAMMER WITH
MODEL 800 POWER UNIT

7032 So. 196th - Kent, WA. 98032 - (206) 872-0141 / Fax (206) 872-8710

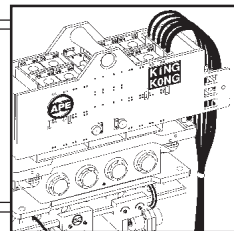

- APPENDIX A - CAT 3412 Twin Turbo 800 HP Engine

A-1C. ENGINE OPERATION (Continued...)

Water Temperature Gauge

If the temperature gauge reading registers in or near the cold range (white) while operating under load:

1. Check the water temperature gauge for accuracy.
2. Check the temperature regulators for proper temperature range. Replace regulators if necessary.

Fuel pressure

If the fuel filter gauge registers in the OUT range, clean the primary fuel filter, if so equipped. Install new secondary or final fuel filter elements if gauge still registers OUT. See the FUEL MAINTENANCE INSTRUCTIONS and FUEL SPECIFICATIONS.

Ammeter:

The ammeter reading is normal when the indicator is at or on the (+) side of zero, when the engine is running at rated speed. If indicator is to the left (-) side of zero, investigate and correct cause.

Air Cleaner Service Indicator

When the gauge indicator locks in the red range, service the air cleaner. With the engine stopped.

Calibrated Gauges

Calibrated gauges are used on some engines to monitor the engine systems. If an abnormal engine condition develops, determine and analyze and correct the cause before a failure and downtime occurs.

If any of the gauges register at or outside the operating limits, investigate and correct any malfunction. See TROUBLESHOOTING for guidance.

**WARNING: Shut the engine down if work on or around the engine is required.
DO NOT OPERATE THE ENGINE WITH THE GAUGES REGISTERING AT OR OUTSIDE
THE LIMITS.**



OPERATION / MAINTENANCE MANUAL

MODEL 400 VIBRATORY HAMMER WITH
MODEL 800 POWER UNIT

7032 So. 196th - Kent, WA. 98032 - (206) 872-0141 / Fax (206) 872-8710

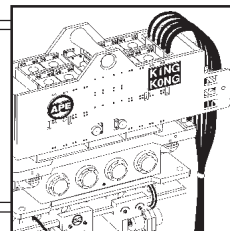

- APPENDIX A - CAT 3412 Twin Turbo 800 HP Engine

A-1C. ENGINE OPERATION (Continued...)

Altitude Operation

The fuel system settings and altitude limits are stamped on the engine information plate. When an engine is moved to a higher altitude, these settings must be changed by your Caterpillar dealer in order to prevent damaging the turbocharger, and to provide maximum engine efficiency. If the engine is moved to a lower altitude than that which is stamped on the engine information plate, the engine can be operated safely; however, it will deliver less than rated horsepower, and the fuel settings should be changed by your Caterpillar dealer to obtain rated horsepower.

Stopping

1. Flywheel clutch operation: Quickly pull the clutch lever to the released position.
2. Reduce engine speed to half speed. Run for 5-10 minutes to cool engine.
3. Reduce engine speed to low idle.
4. Observe the crankcase oil level while the engine is idling. Maintain the oil level between the ADD and FULL marks on the side of the dipstick stamped, CHECK WITH ENGINE RUNNING. See the LUBRICATION AND MAINTENANCE SECTION.
5. Stop the engine.

After Stopping Checks And Procedures

1. Fill the fuel tank. See the LUBRICATION AND MAINTENANCE SECTION: Fuel Tank Maintenance.
2. Drain the raw water system if below freezing temperatures are expected; see: Draining Raw Water System.
3. If below freezing temperatures are expected, allow the engine jacket water expansion tank to cool, then check the coolant for proper antifreeze protection. Add permanent-type antifreeze, if required.
4. Repair any leaks, make minor adjustments, tighten loose bolts, etc.
5. Observe the Service Meter reading. Perform the periodic maintenance as instructed in the LUBRICATION AND MAINTENANCE CHART.



OPERATION / MAINTENANCE MANUAL

MODEL 400 VIBRATORY HAMMER WITH
MODEL 800 POWER UNIT

7032 So. 196th - Kent, WA. 98032 - (206) 872-0141 / Fax (206) 872-8710

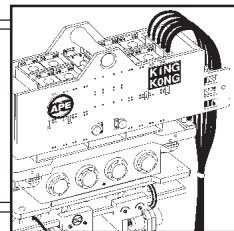

- APPENDIX A - CAT 3412 Twin Turbo 800 HP Engine

Starting The Engine

1. Perform all prestart checks outlined previously.
2. Place the CONTROL switch in the MANUAL position to crank the engine.
3. When the engine starts and engine rpm reaches 600 rpm and the oil pressure registers 22 psi (1.5 kg/cm²) the starting motor will automatically disconnect from the start circuit.
4. Start the load.
5. Regulate the engine speed with the RAISE LOWER switch to the required instrument panel gauge readings.

Stopping The Engine

1. Remove the load.
2. Reduce engine speed to low idle: Push down and hold the RAISE-LOWER switch until the engine low idle speed is reached.
3. While the engine is idling, check the engine oil level. Oil level must be maintained between the ADD and FULL marks on the side of the dipstick marked "CHECK WITH ENGINE RUNNING".
4. Stop the engine.

(Solenoid Shutoff)

- a. Move the control switch to the STOP or OFF positions. (Do not confuse this with the "RAISE-LOWER" switch.)

(PSG Governor:)

- b. Move the shutoff lever forward, or hold the lever up, depending upon installation. Hold the lever in this position until the engine stops.

5. Fill the fuel tank. See the LUBRICATION AND MAINTENANCE section.
6. Drain the raw water system if below freezing temperatures are expected.

Observe the Service Meter reading. Perform the periodic maintenance as instructed in the LUBRICATION AND MAINTENANCE CHART.



OPERATION / MAINTENANCE MANUAL

MODEL 400 VIBRATORY HAMMER WITH
MODEL 800 POWER UNIT

7032 So. 196th - Kent, WA. 98032 - (206) 872-0141 / Fax (206) 872-8710

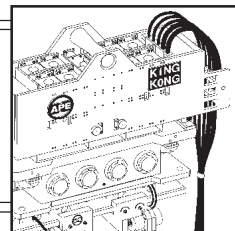

- APPENDIX A -

CAT 3412 Twin Turbo 800 HP Engine

A-1D. Determining Cause Of Shutdown

CAUTION: If the engine has been shutdown by a safety device, don't start the engine and place it into service without having the cause of the shutdown investigated and corrected

Low Oil Pressure Checks

If the low oil pressure shutoff control has stopped the engine, make the following checks:

1. Check the water temperature gauge. Determine if the engine was overheated. Check for external water leaks.

WARNING: Beware of steam or scalding water. Do not attempt to loosen the radiator cap until the temperature gauge indicates the coolant has sufficiently cooled. Then, loosen the cap slowly.

2. Check the oil level. Oil level must be between the ADD and FULL marks on the side of the dipstick stamped CHECK WITH ENGINE STOPPED.
3. If the oil level is below the ADD mark, check for oil spray and/or oil accumulations. If any are found, have the necessary repairs made. Before starting, add oil to the FULL mark.
4. Reset the shutoff control.
5. Remove the load and start the engine at its slowest speed. Be prepared to shut the engine down manually.
6. Be alert for unusual sounds or noises. If the engine knocks, stop the engine immediately and call your engine dealer.
7. If the engine blows excessive black exhaust or has excessive crankcase blow-by, the engine may need reconditioning. Stop the engine and call your engine dealer.
8. If the engine runs satisfactorily, observe the oil pressure gauge. If satisfactory pressure is not indicated, shut the engine down; call your engine dealer.
9. If proper oil pressure is registered, check to see if the reset knob has moved to the run position. If the knob does not move, stop the engine. Check the shutoff control, the oil line, and the oil pressure gauge. Have necessary repairs made.
10. If the oil pressure gauge registers normal oil pressure, if the knob on the shutoff control moves to the run position, and if the engine operation is otherwise satisfactory, determine if the high water temperature shutoff may have shut down the engine.



OPERATION / MAINTENANCE MANUAL

MODEL 400 VIBRATORY HAMMER WITH
MODEL 800 POWER UNIT

7032 So. 196th - Kent, WA. 98032 - (206) 872-0141 / Fax (206) 872-8710

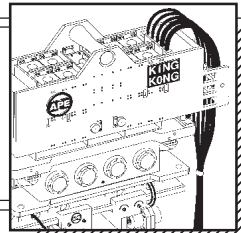

- APPENDIX A -

CAT 3412 Twin Turbo 800 HP Engine

A-1D. Determining Cause Of Shutdown (Continued...)

High Water Temperature Checks-Engine Running

1. Determine if the load was too great for the engine - Reduce the load and allow the engine to cool while running.
2. If pressure steam or water leaks are visible, remove the load and stop the engine. Have necessary repairs made.
3. Check for collapsing or deteriorated water hoses. Have repairs made.
4. Check for noisy water pump operation. Have necessary repairs made.
5. Refill the cooling system with a solution of water and permanent-type antifreeze if below freezing temperatures are expected; or with a solution of approved water and Corrosion Inhibitor. Follow the instructions on the container.

WARNING: DO NOT remove the pressure cap on an overheated engine. The coolant is under pressure and relieving the pressure will cause the coolant to flash into steam.

NOTE: If there is adequate coolant in the cooling system, gradual cooling is preferred by running the engine at half speed. This eliminates hot spots in the engine, and possible failure.

High Water Temperature Checks-Engine Stopped and Cold

1. Check coolant level. Determine if the coolant has proper antifreeze protection. A 50-50 solution of permanent-type antifreeze and approved water will give protection below -200F (-290C).
2. Check to be sure the raw water valve has been opened.
3. Check engine room vents and/or louvers. Be sure the engine is receiving sufficient air.
4. Be sure temperature regulators are operating at proper temperature range.
5. Inspect all water hoses carefully for collapsing, external and internal failures. Replace hoses as required.
6. Have the cooling system cleaned.

CAUTION: If severe or prolonged overheating has occurred, contact your engine dealer to have your engine checked for possible damage.



OPERATION / MAINTENANCE MANUAL

MODEL 400 VIBRATORY HAMMER WITH
MODEL 800 POWER UNIT

7032 So. 196th - Kent, WA. 98032 - (206) 872-0141 / Fax (206) 872-8710

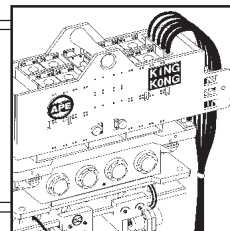

- APPENDIX A -

CAT 3412 Twin Turbo 800 HP Engine

A-2. MAINTENANCE RECOMMENDATIONS

CAUTION: Never add coolant to an overheated engine; allow the engine to cool first.

Cooling

Check specific gravity of antifreeze solution frequently in cold weather to assure adequate protection. Coolant should be drained and replaced "Every 2000 Service Meter Units." With additions of Cooling System Inhibitor or the use of Coolant Conditioner Elements as recommended, the drain period can be extended to "Every 4000 Service Meter Units."

All water is corrosive at engine operating temperature. The cooling system should be protected with inhibitor at all times regardless of concentration of antifreeze. This can be done by maintaining a 3% concentration of liquid Cooling System Inhibitor or by using Coolant Conditioner Elements.

Never use both the liquid cooling system inhibitor and coolant elements at the same time.

Do not use Cooling System Inhibitor or Coolant Conditioner Elements with Dowtherm 209 Full-Fill Coolant.

Whenever draining and refilling cooling system, always recheck the coolant level when the engine reaches normal operating temperature.

Filling at over 5 U.S. gallons (19 liters) per minute can cause air pockets in the cooling system.

Premix antifreeze solution to provide protection to the lowest expected ambient temperature. Pure undiluted antifreeze will freeze at -100F (-23,C).

Operate with a thermostat in the cooling system all year-round. Cooling system problems can arise without a thermostat.

Electrical

CAUTION: When using jumper cables to start the engine, be sure to connect in parallel: **POSITIVE (+) to POSITIVE (+) and NEGATIVE (-) to NEGATIVE (-).**

Scheduled Oil Sampling

Use scheduled Oil sampling to monitor the engine's condition and maintenance requirements. Each oil sample should be taken when the oil is hot, and well mixed, to insure a sample which is representative of the oil in the compartment.

Consult your engine dealer for complete information, and assistance in establishing a Scheduled Oil Sampling program for your equipment.



OPERATION / MAINTENANCE MANUAL

**MODEL 400 VIBRATORY HAMMER WITH
MODEL 800 POWER UNIT**

7032 So. 196th - Kent, WA. 98032 - (206) 872-0141 / Fax (206) 872-8710

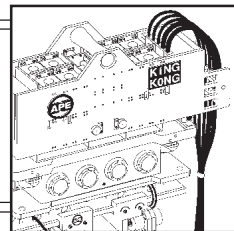

- APPENDIX A -

CAT 3412 Twin Turbo 800 HP Engine

A-2. MAINTENANCE RECOMMENDATIONS (Continued...)

Fuel

CAUTION: Fill fuel tank at the end of each day of operation to drive out moisture-laden air and to prevent condensation. Do not fill the tank to the brim. The fuel expands when it gets warm and may overflow.

Water and sediment should be drained from the fuel tank at the start of each shift or after the fuel tank has been filled and allowed to stand for 5 to 10 minutes.

Drain fuel tank of moisture and sediment as required by prevailing conditions.

After changing fuel filters, always bleed fuel system to remove air bubbles from system.

Air intake

Service air cleaners when RED band in indicator locks in visible position.

A-2A. LUBRICATION SPECIFICATIONS

Crankcase Lubricating Oils

Use oils which meet Engine Service Classification (MIL-L-2104D) or CD/TO-2. These are additive-type oils that have been approved for use in Diesel Engines.

Consult the "EMA Lubricating Oils Data Book," Form SEBU5939, for a listing of CD oil brands.

The proper SAE grade of oil to select is determined by the ambient temperature at which the engine is started and the maximum ambient temperature in which the engine will be operating.

To determine if the oil in the crankcase will flow in cold weather, remove the oil dipstick before starting. If the oil will flow off, the oil is fluid enough to circulate properly.

Lubricating Grease

Use Multipurpose-type Grease (MPGM) which contains 3-5% molybdenum disulfide conforming to MIL-M-7866, and a suitable corrosion inhibitor. NLGI No.2 Grade is suitable for most temperatures. Use NLGI No. 0 or No. 1 Grade for extremely low temperatures.



OPERATION / MAINTENANCE MANUAL

MODEL 400 VIBRATORY HAMMER WITH
MODEL 800 POWER UNIT

7032 So. 196th - Kent, WA. 98032 - (206) 872-0141 / Fax (206) 872-8710

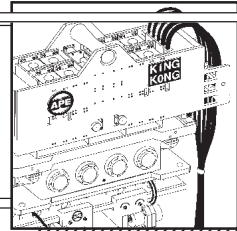

- APPENDIX A - CAT 3412 Twin Turbo 800 HP Engine

A-2. MAINTENANCE RECOMMENDATIONS (Continued...)

A-2B. FUEL SPECIFICATIONS

No. 2 fuel oil and No. 2D diesel fuel are recommended for use in Diesel Engines. In extreme cold temperatures use No. 1 fuel oil or No.1 D diesel fuel.

In selecting a fuel, note that distillate fuels are especially desirable because the fuel is heated to a vaporous state and condensed, thus eliminating all sediment and residue.

A-2C. COOLANT SPECIFICATIONS

Water used in the jacket water cooling system should be clean, and as free as possible from scale forming minerals or corrosive chemicals. Artificially softened water should not be used. Treating the water with Coolant Inhibitor, or equivalent will help prevent the formation of rust and pitting. It will also retard, and in some cases completely eliminate, mineral deposits in the engine.

The most efficient and satisfactory corrosion protection for the cooling system is to maintain proper level of coolant inhibitor and antifreeze solution. The use of auxiliary water filters is not recommended.

During freezing weather use the proper permanent type antifreeze and water solution to prevent freezing.

Before placing the engine in operation, make sure a 3% concentration of Corrosion Inhibitor has been added to the cooling system. This 3% concentration must be maintained in cooling systems which are filled with water and systems protected with ethylene glycol antifreeze mixture, regardless of antifreeze concentration.

WARNING: Inhibitors contain alkali. Avoid contact with eyes. To prevent personal injury, avoid prolonged or repeated contact with skin.

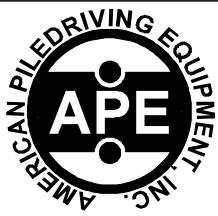

OPERATION / MAINTENANCE MANUAL

MODEL 400 VIBRATORY HAMMER WITH
MODEL 800 POWER UNIT

7032 So. 196th - Kent, WA. 98032 - (206) 872-0141 / Fax (206) 872-8710

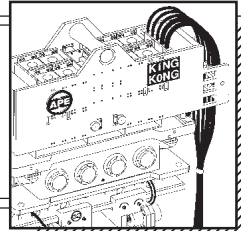

- APPENDIX A -

CAT 3412 Twin Turbo 800 HP Engine

A-2. MAINTENANCE RECOMMENDATIONS (Continued...)

A-2D. LUBRICATION AND MAINTENANCE

The LUBRICATION AND MAINTENANCE CHART lists all serviceable items commonly ordered on this engine. The maintenance tune intervals are expressed in "Operating Hours".

Daily	Weekly	250 Hours or 6 months	1500 Hours or 1 Year	6000 Hours or 2 Years	6000 Hours or 3 Years
<ul style="list-style-type: none"> • Check operator's report • Check and bring to correct level - Engine Oil - Coolant • Visually inspect fan. • Visually inspect engine for damage, leaks, loose or frayed belts and correct or record for future action. • Drain fuel-water separator. 	<p>Repeat Daily Check</p> <ul style="list-style-type: none"> • Check air intake system for wear points or damage to piping, loose clamps, and leaks. • Check air cleaner restriction. • Check and clean air cleaner element. • Drain moisture from air tanks. 	<p>Repeat Daily and Weekly Check</p> <ul style="list-style-type: none"> • Change Lubricating Oil. • Change Lubricating Oil Filters. • Change Fuel Filter. • Change Coolant Filter. • Clean Crankcase Breather. • Check engine coolant concentration level. Add make-up if required. • Replace final Fuel Filter/Clean primary Fuel Filter. Drain water from fuel tank. • Inspect/Replace Alternator, Fan and Accessory Drive Belts. • Inspect/Replace Hoses and Clamps. • Lubricate Fan Drive Bearings. • Clean/Check Battery electrolyte level. 	<p>Repeat Previous Intervals</p> <ul style="list-style-type: none"> • Adjust valves and injectors. • Steam clean engine. • Check torque on turbocharger mounting nuts. • Check torque on engine mounting bolts. • Replace hoses as required. • Check/Adjust engine valve lash. • Check/Adjust low idle speed. • Test/Exchange fuel injection nozzles. • Inspect coolant pump. Clean cooling system. (Internal) • Inspect/Rebuild Alternator. 	<p>Repeat Previous Intervals</p> <ul style="list-style-type: none"> • Clean cooling system and change coolant and antifreeze. • Inspect temperature regulator. • Inspect/Rebuild turbocharger. • Inspect/Rebuild starter. • Check and adjust clutch. 	<p>Repeat Previous Intervals Which Are Due</p> <ul style="list-style-type: none"> • Clean and calibrate the following: (Rebuild or exchange if required.) - Injectors. - Fuel pump. - Air compressor. - Fan clutch. - Water pump. - Fan hub. - Fan idler pulley assembly. - Vibration damper.
<p>Follow the manufacturer's recommended maintenance procedures for the starter, alternator, generator, batteries, electrical components, engine brake, exhaust brake, air compressor, freon compressor, and fan clutch. At each scheduled maintenance interval, perform all previous maintenance checks which are due for scheduled maintenance.</p>					



OPERATION / MAINTENANCE MANUAL

MODEL 400 VIBRATORY HAMMER WITH
MODEL 800 POWER UNIT

7032 So. 196th - Kent, WA. 98032 - (206) 872-0141 / Fax (206) 872-8710

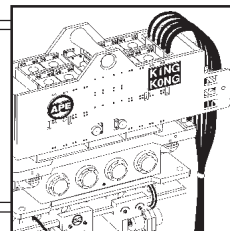

- APPENDIX A -

CAT 3412 Twin Turbo 800 HP Engine

A-2E. ELECTRICAL SYSTEM

The following topics describe care and maintenance of the electrical system components. These components functioning together produce the energy needed for operating the electrical equipment on the engine and each is dependent upon the others for satisfactory operation. In the event of failure or improper operation, it is essential to check the entire electrical system as a defect in one component can cause damage to another. Many electrical system problems can be traced to loose or corroded connections. Keep connections tight and make sure the wiring insulation is in satisfactory condition. Most of the electrical system testing can be performed while the components are on the engine. It should be remembered, if a malfunction is found on test, the component must be removed for further testing, repair or replacement.

Battery

Every 250 hours check the electrolyte level of each cell and the general condition of the battery. Maintain the electrolyte level to the base of each vent well. The make-up water must be one of the following (in order of preference):

1. Distilled water.
2. Odorless, tasteless drinking water-
3. Iron free water.

WARNING: Never add acid or electrolyte.

Cleaning Battery

Mix a weak solution of baking soda and water. Apply the solution with a soft bristle brush. Be careful not to get cleaning solution into the battery. Thoroughly rinse the battery and battery tray with clean water. Apply grease to battery cable clamps and terminals and to all threads.

Installing Battery

1. Be sure the battery tray is clean and free of foreign objects.
2. Be sure terminal posts and cable clamps are clean.
3. Place the battery in the tray. Tighten the hold down clamps evenly until the battery is snug. Do not over tighten.
4. Connect the "hot" terminal first. Be sure the top of the cable terminal is pushed down even with the top of the terminal post. Tighten the clamp firmly.

WARNING: Always connect the "hot" terminal first to minimize arcing. Otherwise injury or damage could result.

5. Connect the "grounded" terminal last. Be sure the top of the cable terminal is pushed down even with the top of the terminal post. Tighten the clamp firmly.
6. Apply a thin coating of grease over the cable clamps, terminals and hold down fasteners.



OPERATION / MAINTENANCE MANUAL

MODEL 400 VIBRATORY HAMMER WITH
MODEL 800 POWER UNIT

7032 So. 196th - Kent, WA. 98032 - (206) 872-0141 / Fax (206) 872-8710

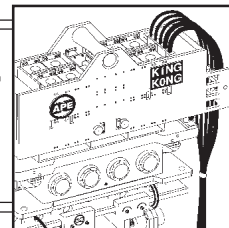

- APPENDIX A -

CAT 3412 Twin Turbo 800 HP Engine

A-2E. ELECTRICAL SYSTEM (Continued...)

Charging the Battery

WARNING: Never smoke in the area where batteries are being charged. Hydrogen gas is given off at each vent cap during charging. Hydrogen mixed with air is highly explosive.

1. Connect positive charger clamp to positive battery terminal.
2. Connect negative charger clamp to negative battery terminal.
3. Connect charger power cord to proper outlet.
4. Allow battery to charge slowly.

CAUTION: If battery is charged too rapidly, the battery will be damaged.

5. After the battery is charged, disconnect charger power cord from outlet; remove charger clamp from negative battery terminal; remove charger clamp from positive battery terminal.

A-3. Engine Troubleshooting.

-TROUBLESHOOTING INDEX-

ITEM	PROBLEM	ITEM	PROBLEM
1.	Engine Fails to Start	15.	Valve Lash Close-up
2.	Misfiring	16.	Premature Engine Wear
3.	Erratic Engine Speed	17.	Coolant in Engine Lubricating Oil
4.	Low Power	18.	Excessive Black or Gray Smoke
5.	Excessive Vibration	19.	Excessive White or Blue Smoke
6.	Heavy Combustion Knock	20.	Low Engine Oil Pressure
7.	Valve Train Clicking Knock	21.	High Lubricating Oil Consumption
8.	Oil in Coolant	22.	Abnormal Engine Coolant Temperature
9.	Mechanical Knock	23.	Starting Motor Fails to Crank
10.	Excessive Fuel Consumption	24.	Alternator Fails to Charge
11.	Loud Valve Train Noise	25.	Alternator Charging Rate Low or Unsteady
12.	Excessive Valve Lash	26.	Alternator Charging Rate High
13.	Valve Spring Retainer Free	27.	Alternator Noisy
14.	Slobber	28.	Stalls at Low Speed



OPERATION / MAINTENANCE MANUAL

MODEL 400 VIBRATORY HAMMER WITH
MODEL 800 POWER UNIT

7032 So. 196th - Kent, WA. 98032 - (206) 872-0141 / Fax (206) 872-8710

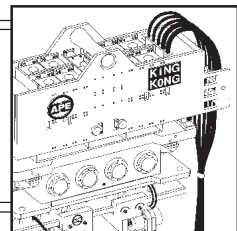

- APPENDIX A -

CAT 3412 Twin Turbo 800 HP Engine

A-3. Engine Troubleshooting. (Continued...)

Possible Causes	Remedy
1. ENGINE FAILS TO START	
No Fuel to Engine	Check for empty fuel tank, plugged fuel tank connections, obstructed or kinked fuel suction lines, fuel transfer pump failure, or plugged fuel filters.
Shutoff Solenoid Sticking*	Solenoid must be energized to shut off engine. Actuate the control that operates the shutoff solenoid and listen for a clicking sound. If clicking sound is not evident and engine will not start, remove the solenoid. Again try to start the engine. If the engine starts, the solenoid is bad. Replace the solenoid.
Fuel Transfer Pump	At cranking speed, the fuel transfer pump should supply fuel to the engine at 3 PSI (20 kPa). If fuel pressure is less than 3 PSI (20 kPa), replace the fuel filter. Check for air in fuel system, sticking, binding or defective fuel bypass valve. If pressure is still low, replace the fuel transfer pump.
Engine Improperly Timed	See your authorized dealer.
Glow Plug Failure	Check glow plugs.
Automatic and Safety Shutoff Controls	Check shutoff controls to ensure they are set properly. See Starting Procedures.
*Optional Equipment	
2. MISFIRING	
Defective Fuel Injection Nozzle or Fuel Pump	Run the engine at the speed where the defect is most pronounced. Momentarily loosen the fuel line nut on the injection pump to "cut out" that cylinder. Check each cylinder in this manner. If one is found where loosening makes no difference in irregular operation, the pump and nozzle for only that cylinder need be treated.
Improper Valve Lash	Set to specified clearance.
Incorrect Fuel Injection Timing	See your authorized dealer.
Low Fuel Supply Pressure	Check fuel supply line for leaks or kinks, air in fuel system, sticking, binding, or defective fuel bypass valve. Replace fuel filter. Check fuel pressure. Fuel transfer pump should supply fuel at 20 to 30 PSI (1.4 to 2.1 kg/CM ²) to the engine when the engine is fully loaded.
Broken or Leaking High Pressure Fuel Line	Replace the line.
Air in Fuel System	Find source of air entry and correct. Bleed system.
Bent or Broken Push Rod	Replace push rod.

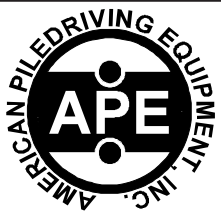

OPERATION / MAINTENANCE MANUAL

MODEL 400 VIBRATORY HAMMER WITH
MODEL 800 POWER UNIT

7032 So. 196th - Kent, WA. 98032 - (206) 872-0141 / Fax (206) 872-8710

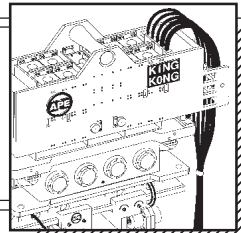

- APPENDIX A -

CAT 3412 Twin Turbo 800 HP Engine

A-3. Engine Troubleshooting. (Continued...)

Possible Causes	Remedy
3. ERRATIC ENGINE SPEED	
Governor Control Linkage	Adjust external linkage to obtain sufficient travel. Replace if damaged, bent, or linkage is too short.
Governor Failure	Look for damaged or broken springs, linkage, or other components. Determine if the rack can be moved manually. If any distress is noted in any of these components, replace as necessary.*
4. LOW POWER	
Fuel Nozzle Failure	Run the engine at the speed where the defect is most pronounced. Momentarily loosen the fuel line nut on the injection pump to "cut out" that cylinder. Check each cylinder in this manner. If one is found where loosening makes no difference in irregular operation, the pump and nozzle for only that cylinder need be tested.
Poor Quality Fuel	Drain, clean and bleed fuel system. Replace fuel filter. Fill fuel tank with proper grade of fuel.
Turbocharger Carboned or Otherwise Dragging	Inspect and repair or replace turbo charger as necessary.*
Leaks in Air Induction System	Check inlet manifold pressure. Check air cleaner for restriction.
Incorrect Fuel Injection Timing	See your authorized dealer.
Excessive Valve Lash	Set to specified clearance.
Low Fuel Supply Pressure	Check fuel supply line for leaks or kinks, air in fuel system, sticking, binding or defective fuel bypass valve. Replace fuel filter. Check fuel pressure. Fuel transfer pump should supply fuel to 20 to 30 PSI (1.4 to 2.1 kg/CM ²) to the engine when the engine is fully loaded.
5. EXCESSIVE VIBRATION	
Loose, Worn or Defective Engine Mounts as necessary.	Tighten all mounting bolts securely. Replace components as necessary.
Loose Pulley and Damper	
Loose or Worn Coupling on Driven Equipment	Inspect, align and tighten coupling to driven equipment.
Defective Damper or Pulley	Replace damper or pulley.
Misfiring	See ITEM 2.



OPERATION / MAINTENANCE MANUAL

MODEL 400 VIBRATORY HAMMER WITH
MODEL 800 POWER UNIT

7032 So. 196th - Kent, WA. 98032 - (206) 872-0141 / Fax (206) 872-8710

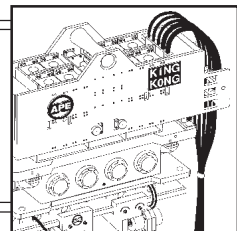

- APPENDIX A -

CAT 3412 Twin Turbo 800 HP Engine

A-3. Engine Troubleshooting. (Continued...)

Possible Causes	Remedy
6. HEAVY COMBUSTION KNOCK	
Air in Fuel System	Bleed air from system.
Defective Fuel Injection Pump Plunger and Barrel Assembly	Replace.*
Defective Fuel Injection Nozzle	Replace.
Incorrect Fuel Injection Timing	See your authorized dealer.*
7. VALVE TRAIN CLICKING NOISE	
Excessive Valve Lash	Set to specified clearance.
Broken Valve Spring(s)	Replace valve spring(s) and all other damaged components.*
Insufficient Lubrication	Check lubrication in valve compartment. Should be very wet at all speeds. Oil passages should be cleaned, especially those leading to the cylinder head.
8. OIL IN COOLANT	
Failed Oil Cooler Core	Replace oil cooler core.
Failed Head or Spacer Plate Gaskets	Replace head and spacer plate gaskets.
Cracked or Defective Cylinder Block	Replace cylinder block.*
Cracked or Defective Head	Replace cylinder head.
9. MECHANICAL KNOCK	
Engine Connecting Rod Bearing Failure	Replace the bearing. Check the connecting rod and crankshaft. Replace if necessary.*
Main Bearing Failure	Replace bearings.*
Damaged Timing Gear Train	Replace components as necessary.*
Broken Crankshaft	Replace crankshaft.*
Fuel Dilution of Crankcase Oil	Correct fuel leakage into crankcase oil.

*Authorized dealers are equipped with the necessary tools and personnel familiar with disassembly procedures to perform these services.



OPERATION / MAINTENANCE MANUAL

MODEL 400 VIBRATORY HAMMER WITH
MODEL 800 POWER UNIT

7032 So. 196th - Kent, WA. 98032 - (206) 872-0141 / Fax (206) 872-8710

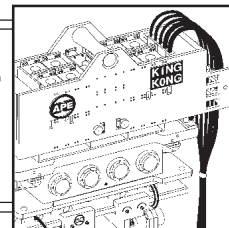

- APPENDIX A -

CAT 3412 Twin Turbo 800 HP Engine

A-3. Engine Troubleshooting. (Continued...)

Possible Causes	Remedy
10. EXCESSIVE FUEL CONSUMPTION	
Fuel System Leaks	Large changes in fuel consumption may result. Internal leaks will probably be accompanied by low engine oil pressure and increased oil level in the engine oil sump. Replace leaking components.
Fuel and Combustion Knock	Small but measurable increases in fuel consumption maybe the result of defective fuel nozzles, misfiring or factors contributing to loss of power. See ITEM 2 and ITEM 5.
Incorrect Fuel Injection Timing	See your authorized dealer.
11. LOUD VALVE TRAIN NOISE	
Bent or Broken Valves	Replace damaged parts.*
Broken Camshaft	Replace all damaged parts. Clean engine thoroughly.
Broken or Severely Worn Valve Lifters	Replace camshaft and valve lifters. Check for sticking valves and bent valve stems. Clean engine thoroughly. Set valve lash to specified clearance.
12. EXCESSIVE VALVE LASH	
Severely Worn Cam Lobes	Check valve lash. Replace camshaft and followers. Clean engine thoroughly. Set valve lash to specified clearance.
Broken or Severely Worn Valve Lifters	Replace valve lifters. Check camshaft for wear. Check for sticking valves and bent valve stems. Clean engine thoroughly. Set valve lash to specified clearance.
Valve Tip Wear	Set valve lash to specified clearance. If wear is excessive, replace valve.
Moderate Valve Lifter Face Wear	Set valve lash to specified clearance. If wear is excessive, replace valve lifter.
Push Rod Wear	Set valve lash to specified clearance. If wear is excessive, replace push rod.
Rocker Arm Anvil Wear	Set valve lash to specified clearance. If wear is excessive, replace rocker arm.
Insufficient Lubrication	Check lubrication in valve should be very wet at high idle speeds, but only damp at low idle. Oil passages should be cleaned, especially those leading to the cylinder head.



OPERATION / MAINTENANCE MANUAL

MODEL 400 VIBRATORY HAMMER WITH
MODEL 800 POWER UNIT

7032 So. 196th - Kent, WA. 98032 - (206) 872-0141 / Fax (206) 872-8710

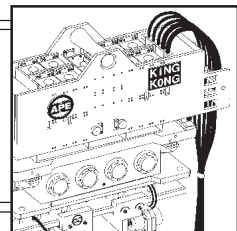

- APPENDIX A -

CAT 3412 Twin Turbo 800 HP Engine

A-3. Engine Troubleshooting. (Continued...)

Possible Causes	Remedy
13. VALVE SPRING RETAINER FREE	
Broken Keepers	Extensive engine damage may result from dropped valve. Replace all damaged parts.*
Broken Valve Spring	Replace valve spring.*
Broken Valve	Replace valve and any other damaged parts.*
14. SLOBBER	
Excessive Valve Guide Wear	Recondition cylinder head assembly.*
Excessive Lubricating Oil in Valve Compartment in place.	Check rocker arm shaft and plugs to assure that they are
Worn Piston Rings and/or Liners	Inspect and replace components as necessary.*
15. VALVE LASH CLOSE-UP	
Valve Face and/or Seat Wear	Adjust valves to specified clearance. Recondition cylinder head.
16. PREMATURE ENGINE WEAR	
Intake Piping Failure (Air Cleaner)	Inspect all gaskets and piping for leaks. Repair all leaks.
Excessive Fuel Dilution of Lubricating Oil	Replace leaking components. This will probably be accompanied by high fuel consumption and low engine oil pressure. Tighten fuel injection line fittings under valve cover.
Dirt in Lubricating Oil	Locate and correct source of dirt entry, Change lubricating oil. Change oil filter.
17. COOLANT IN ENGINE LUBRICATING OIL	
Oil Cooler Failure	Replace oil cooler core.
Cylinder Head Gasket Failure	Replace gasket. Maintain proper torque on cylinder head bolts.
Cracked or Defective Cylinder Head	Replace cylinder head.*
Cracked or Defective Cylinder Block	Replace cylinder block.*

*Authorized dealers are equipped with the necessary tools and personnel familiar with disassembly and assembly procedures to perform these serviced.



OPERATION / MAINTENANCE MANUAL

MODEL 400 VIBRATORY HAMMER WITH
MODEL 800 POWER UNIT

7032 So. 196th - Kent, WA. 98032 - (206) 872-0141 / Fax (206) 872-8710

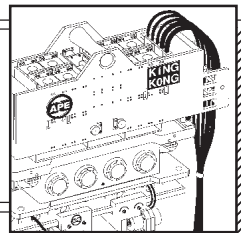

- APPENDIX A -

CAT 3412 Twin Turbo 800 HP Engine

A-3. Engine Troubleshooting. (Continued...)

Possible Causes	Remedy
17. COOLANT IN ENGINE LUBRICATING OIL (Cont'd)	
Cylinder Liner Seal Leaking	Replace seals.*
Cracked or Defective Cylinder Liners	Replace cylinder liners.†
18. EXCESSIVE BLACK OR GRAY SMOKE	
Insufficient Combustion Air	Check air cleaner for restriction. Check inlet manifold pressure. Inspect turbocharger for proper operation.
Fuel Nozzle Plugged or Leaking	Replace nozzle.
Incorrect Fuel Injection Timing	See your authorized dealer.
Fuel Ratio Control Improperly Adjusted	Adjust fuel ratio control.*
19. EXCESSIVE WHITE OR BLUE SMOKE	
Valve Guides Worn	Recondition cylinder head assembly.*
Piston Rings Worn, Stuck or Broken	Replace.*
High Crankcase Oil Level	Avoid overfilling. Determine cause and drain excess oil.
Misfiring	See ITEM 2.
Fuel Injection Pump Timing Wrong	See your authorized dealer.
Air in Fuel System	Bleed fuel system.
20. LOW ENGINE OIL PRESSURE	
Engine Oil Diluted with Fuel Oil	Check lip-type seal on fuel transfer pump drive shaft. Drain crankcase and refill with clean lubricant.
Excessive Crankshaft Bearing Clearance	Replace bearings and/or crankshaft.* Check oil filter operation.
Excessive Timing Gear Bearing Clearances	Inspect bearings and replace components as necessary.
Excessive Rocker Arm Bore or Rocker Arm Shaft Wear	Check lubrication. Replace components as necessary.
Defective Oil Pump	Repair or replace.*
Defective Suction Bell	Replace.



OPERATION / MAINTENANCE MANUAL

MODEL 400 VIBRATORY HAMMER WITH
MODEL 800 POWER UNIT

7032 So. 196th - Kent, WA. 98032 - (206) 872-0141 / Fax (206) 872-8710

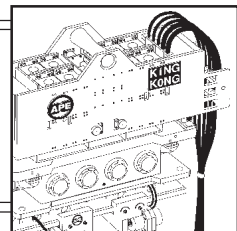

- APPENDIX A -

CAT 3412 Twin Turbo 800 HP Engine

A-3. Engine Troubleshooting. (Continued...)

Possible Causes

Remedy

20. LOW ENGINE OIL PRESSURE (Cont'd)

Clogged Oil Filter or Cooler

Repair or replace as necessary.

Oil Pump Relief Valve Stuck

Clean valve and housing. Replace if necessary.

21. HIGH LUBRICATING OIL CONSUMPTION

Oil Leaks

Replace gaskets or seals and tighten all connections.

Excessive Oil to Intake

See ITEM 15. Valve Guides.

Excessive Valve Guide Wear

See ITEM 15.

Crankcase Oil Level Too High

Avoid overfilling. Determine cause and drain excess oil.

High Oil Temperature

Check oil cooler bypass valve. Replace if defective. Clean oil cooler core.

Worn Piston Rings and/or Liner

Replace components as necessary.*

22. ABNORMAL ENGINE COOLANT TEMPERATURE

Combustion Gases in Coolant

Determine point at which gases enter the system. Repair or replace components as necessary.

Defective Water Temperature Regulator or Temperature Gauge

Check temperature regulator for proper opening temperature and correct installation. Check temperature gauge. Replace if necessary.

Coolant Level Low

Determine cause-replace leaking gaskets and hoses. Tighten connections. Add coolant.

Air Flow Through Radiator Restricted

Remove all debris from outer surface of radiator.

Defective Water Pump

Check water pump impeller. Repair water pump as necessary.

Radiator Small for Engine Application

Install correct size radiator.

Fan Improperly Positioned in Shroud or Not Shrouded

Position fan correctly.*

*Authorized dealers are equipped with the necessary tools and personnel familiar with disassembly and assembly procedures to perform these serviced.

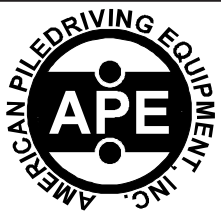

OPERATION / MAINTENANCE MANUAL

MODEL 400 VIBRATORY HAMMER WITH
MODEL 800 POWER UNIT

7032 So. 196th - Kent, WA. 98032 - (206) 872-0141 / Fax (206) 872-8710

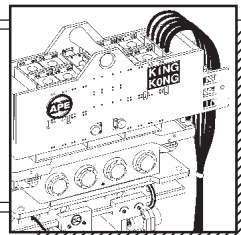

- APPENDIX A -

CAT 3412 Twin Turbo 800 HP Engine

A-3. Engine Troubleshooting. (Continued...)

Possible Causes

Remedy

22. ABNORMAL ENGINE COOLANT TEMPERATURE

Incorrect Fuel Injection Timing

See your authorized dealer.

Incorrect Water Piping Connections
from Engine to Radiator

Check shunt line (if equipped) and
vent line for correct installation.

23. STARTING MOTOR FAILS TO CRANK

Low Output from Battery

Check battery and charge or replace.

Defective Wiring or Switch

Repair or replace.

Defective Solenoid

Replace.

Defective Starting Motor

Repair.

24. ALTERNATOR FAILS TO CHARGE

Drive Belt Loose

Adjust belt.

Open or High Resistance in
Charging or Ground Return
Circuits or Battery Connections

Inspect all cables and connectors.
Clean, re tighten or replace defective
parts.

Excessively Worn, Open or
Defective Brushes

Replace brush assembly.*

Open Rotor Field Coil

Replace rotor assembly.*

25. ALTERNATOR CHARGING RATE LOW OR UNSTEADY

Drive Belt Loose

Adjust belt.

Intermittent or High Resistance in
Charging or Ground Return Circuits
or Battery Connections

Inspect all cables and connectors.
Clean, re tighten or replace defective
parts.

Excessively Worn, Sticky, or
Defective Brushes

Replace brush assembly.*

Faulty Regulator

Replace regulator.*

Shorted or Open Rectifier Diodes

Replace defective rectifier diode
assembly in alternator.*

Grounded or Shorted Rotor

Replace rotor assembly.*



OPERATION / MAINTENANCE MANUAL

MODEL 400 VIBRATORY HAMMER WITH
MODEL 800 POWER UNIT

7032 So. 196th - Kent, WA. 98032 - (206) 872-0141 / Fax (206) 872-8710

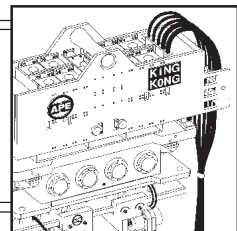

- APPENDIX A -

CAT 3412 Twin Turbo 800 HP Engine

A-3. Engine Troubleshooting. (Continued...)

Possible Causes	Remedy
26. ALTERNATOR CHARGING RATE HIGH	
Loose Connections	Tighten connections to alternator and regulator.
Defective Regulator	Replace regulator.
27. ALTERNATOR NOISY	
Defective Drive Belt	Replace belt.
Misaligned Belt or Pulley	Align drive pulley, alternator pulley and belt.
Loose Pulley	Tighten pulley nut. If keyway is worn, install a new pulley.
Worn Bearings	Replace bearings.
Shorted Rectifiers in Alternator	Replace diode assembly.*
Armature or Rotor Shaft Bent	Replace component.*
*Authorized dealers are equipped with the necessary tools and personnel familiar with disassembly and assembly procedures to perform these serviced.	
28. STALLS AT LOW SPEED	
Idle Speed Too Low	See your authorized dealer
Low Fuel Supply Pressure	Check fuel supply line for leaks or kinks, air in fuel system, sticking, binding, or defective fuel bypass valve. Replace fuel filter. Check fuel pressure. Fuel transfer pump should supply fuel at 20 to 30 PSI to the engine when the engine is fully loaded.
Defective Fuel Nozzle	Replace nozzle
Defective or Damaged Fuel Injection Pumps	Replace damaged or defective parts.
High Parasitic Loads	Check for excessive loading due to auxiliary attachments