

SHEET PILE INSERTS																	
lbs / kg & in / mm	Wt#	A	B	C	D	E	F	G	H	I	J	K	L	M	N	O	P
DCS-1	1,700	16	17	6	5	3.75	31.5	25.5	8.5	16.5	22	10	4	2.9	6.8		
	771	406	432	152	127	95	800	648	219	419	559	254	102	76	172		
DCS-5	3,080	18	19.75	6	5	3.5	42	32	8.5	16.7	25.5	12.25				7.75	37.5
	1,397	457	502	203	127	89	1,067	813	216	425	648	312				197	952
DCS-7	4,050	18	20.25	8	5	3.5	48	32	8.5	16.7	33.5	12.35					37.5
	1,837	457	514	203	127	89	1,220	813	216	425	850	314					952

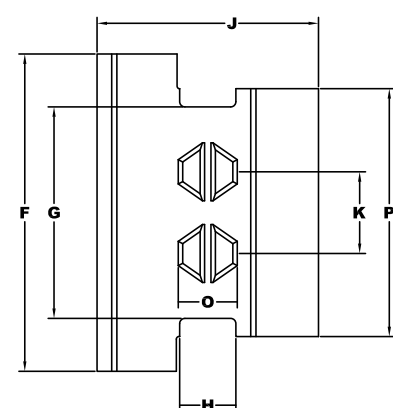
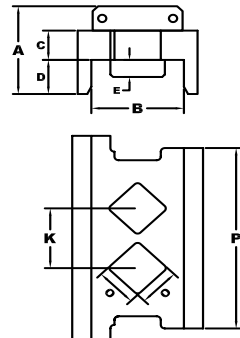
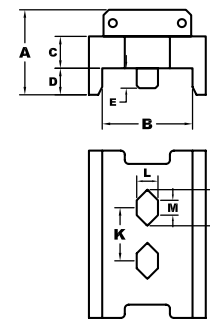
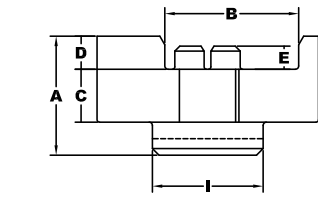
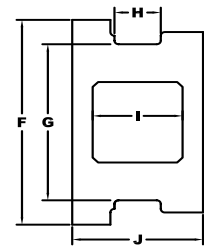
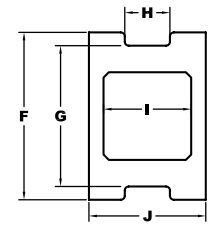

SHEET PILE INSERT DCS-1

SHEET PILE INSERT DCS-5

SHEET PILE INSERT DCS-7



PIPE INSERTS									
lbs / kg & in / mm	Wt#	A	B	C	D	E	F	G	H
16" (406 mm)	730	17	17.1	3	7.87	9.85	11.9	13.85	
	331	432	434	16	200	250	302	352	
24" (610 mm)	1,770	17	20	3	15	17	18.75	22.5	26
	802	431	507	16	381	431	476	577	660
30" (762 mm)	2,340	17	18.5	2.5	11	18	25	31.9	
	1,061	431	470	64	279	457	635	813	

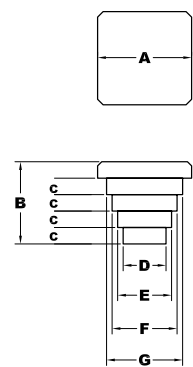

16" PIPE INSERT

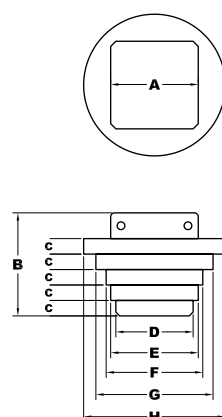

24" PIPE INSERT

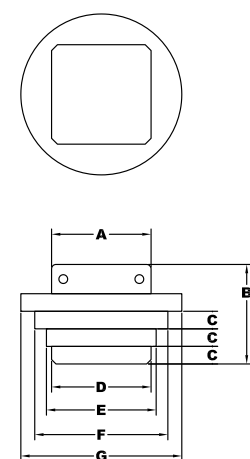

30" PIPE INSERT



STRIKER PLATES				
lbs / kg & in / mm	Wt#	A	B	C
17.75" (450 mm)	440	6	14	17.75
	199	152	356	451
22.5" (572 mm)	650	6	18	22.5
	295	152	457	572
25" (635 mm)	1,036	8	19	25.0
	470	203	485	635
30" (762 mm)	2,400	12	29	30
	635	305	737	762

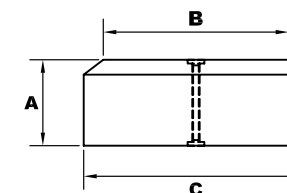

STRIKER PLATE

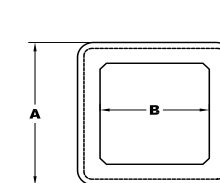

10"- 18" BOX INSERT

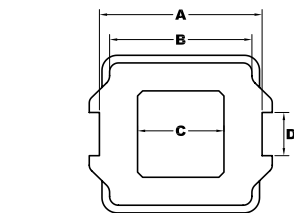

20" BOX INSERT



H-BEAM INSERTS													
lbs / kg & in / mm	Wt#	A	B	C	D	E	F	G	H	I	J	K	L
12" (305 mm) Round	1,060	17	20	5	3	12	17	17.7	26.5				
	481	432	508	127	76	305	432	449	675				
14" (356 mm) Round	1,220	25	20	5	3	12	21	21.65	26.6				
	553	635	508	127	76	305	533	550	676				
12" & 14" (305 & 356 mm) Waffle	850	17	11	5	3	3	20	15	20	12.65	3.75	6.75	1.25
	386	432	279	127	76	76	508	381	508	321	95	171	32
16" & 18" (406 & 457 mm) Waffle	2,140	17	17	5	6	6	26	19	26	19	2.5	13	2.5
	971	432	432	127	152	152	660	482	660	482	64	330	64

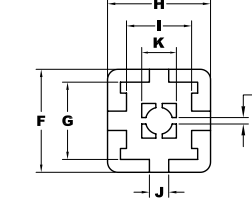
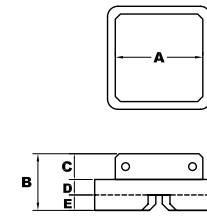

H-BEAM INSERT - WAFFLE

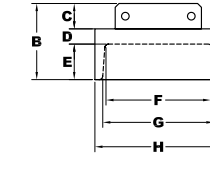
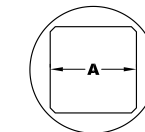

H-BEAM INSERT - ROUND

BOX INSERTS									
lbs / kg & in / mm	Wt#	A	B	C	D	E	F	G	H
10" (254 mm)	1,480	20	17	27	6	16	11.5	14.5	
	671	508	432	685	152	406	293	369	
12" (305 mm)	1,610	20	17	27	6	16	13.5	16.5	
	730	508	432	685	152	406	343	419	
14" (356 mm)	1,560	20	17	27	6	16	15	20	
	708	508	432	686	152	406	381	508	
16" (406 mm)	1,810	22	17	27	6	16	17	20	
	821	359	432	686	152	406	432	508	
18" (457 mm)	2,360	24	17	29	8	16	19	22	
	1,070	610	432	736	203	406	482	559	
20" (508 mm)	2,840	26	24	17	8.5	29	8	16	21.5
	1,288	660	610	432	216	736	203	406	546

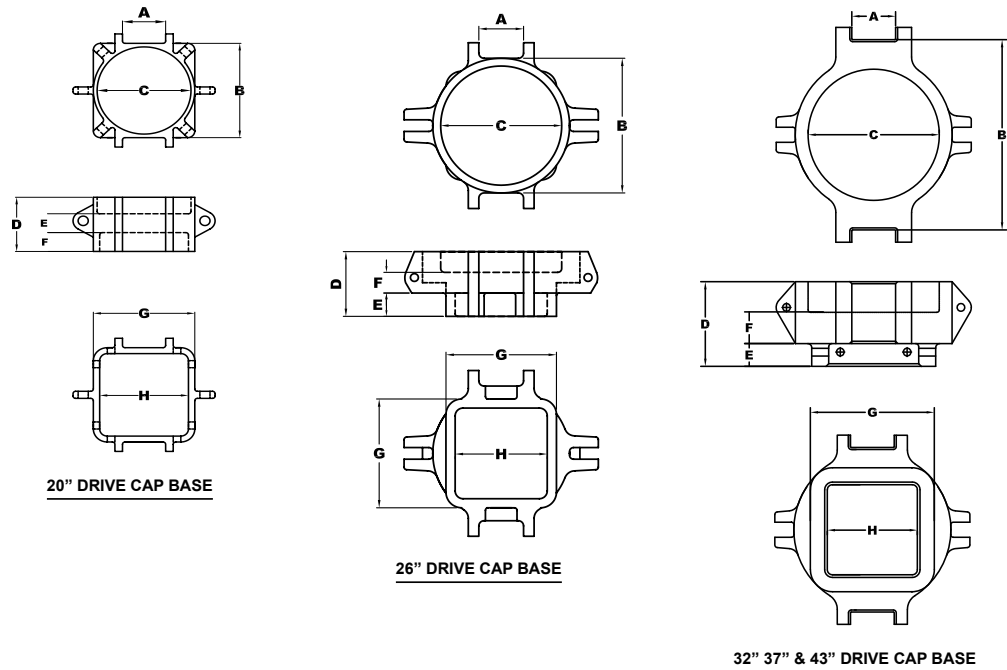

DRIVE CAP BASES										
lbs / kg & in / mm	Wt#	A	B	C	D	E	F	G	H	
20" - 4" (508 - 102 mm)	750 340	8.5 216	20 508	18.25 464	11.5 292	4 102	4 102	20 508	17.5 445	
26" - 6" (660 - 152 mm)	1,270 576	8.5 216	26 660	23 584	14.5 367	4.5 114	4 101	21 533	17.5 445	
26" - 9" (660 - 229 mm)	1,350 612	8.5 216	26 660	23 584	17.5 443	4.5 114	4 101	21 533	17.5 445	
32" - 6" (813 - 152 mm)	2,270 1,030	8.5 216	32 813	25.5 648	16.5 419	4.5 114	6 153	24 612	17.5 445	
32" - 9" (813 - 229 mm)	2,420 1,097	8.5 216	32 813	25.5 648	19.5 495	4.5 114	6 153	24 612	17.5 445	
37" - 6" (940 - 152 mm)	2,790 1,266	8.5 216	37 940	25.5 648	18.5 470	4.5 114	8 203	24 612	17.5 445	
37" - 9" (940 - 229 mm)	3,020 1,370	8.5 216	37 940	25.5 648	19.5 495	4.5 114	6 153	24 612	17.5 445	
43" - 6" (1,092 - 152 mm)	3,400 1,542	8.5 216	43 1092	25.5 648	18.5 470	4.5 114	8 203	24 612	17.5 445	
43" - 9" (1,092 - 229 mm)	4,070 1,846	8.5 216	43 1092	30.5 775	21.5 545	4.5 114	8 203	24 612	17.5 445	

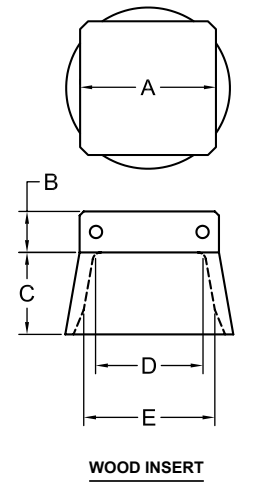

WOOD INSERTS						
lbs / kg & in / mm	Wt#	A	B	C	D	E
17" (432 mm)	893 446	20 508	5 127	11.25 286	15.5 394	17 432
19" (483 mm)	1,175 533	19 484	5 127	18 457	16 406	19 482

TWO PIECE BOX HELMETS														
lbs / kg & in / mm	Wt#	A	B	C	D	E	F	G	H	I	J	K	L	M
24" (610 mm)	8,770 3,978	37 940	32 813	25.5 648	8.5 216	2 51	23 584	9 229	8 203	24.75 629	32 813	37 940	25.5 648	36 914
30" (762 mm)	10,850 4,921	43 1092	37 940	30.5 775	8.5 216	2 51	23 584	9 229	8 203	30.75 781	37 940	43 1092	31.5 800	36 914
36" (914 mm)	14,700 6,667	54 1372	43 1092	30.5 775	8.5 216	2 51	23 584	9 229	8 203	36.75 933	43 1092	54 1372	37.5 953	36 914

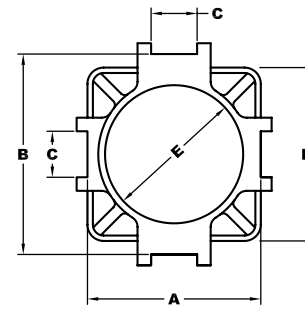

ONE PIECE BOX HELMETS										
lbs / kg & in / mm	Wt#	A	B	C	D	E	F	G	H	I
24" (610 mm)	5,818 2,639	32 813	37 940	8.5 216	32 813	25.5 648	35 889	12 305	19 483	25.5 645
30" (762 mm)	6,195 2,810	37 940	43 1092	8.5 216	36 914	25.5 648	42 1,067	12 305	24 610	31.5 800

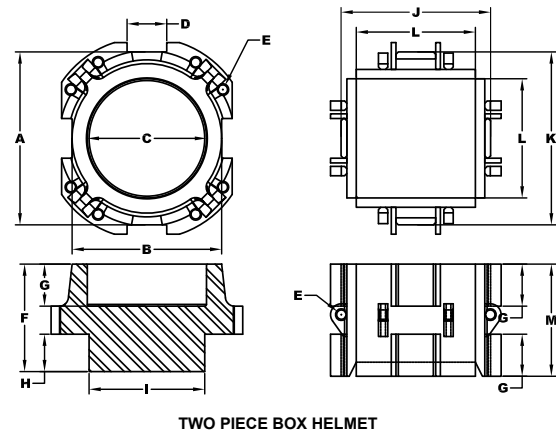
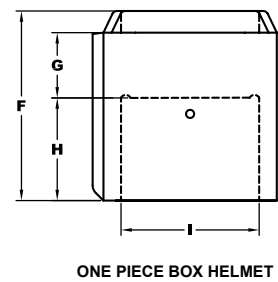

PIPE HELMETS																
PIPE HELMETS	Wt#	A	B	C	D	E	F	G	H	I	J	K	L	M	N	O
32/37" - 25.5" (813/940 - 648 mm)	3,400 1,542	17 432	37 940	8.5 216	25.5 648	24 610	12.5 318	6 152	3 76	2.9 73	2.9 73	2.75 70	17.5 445	19.6 499	26.1 663	32 813
37/43" - 25.5" (940/1092 - 648 mm)	6,660 3,021	43 1,092	37 940	8.5 216	25.5 648	28.5 723	16.5 419	6 152	3 76	3 76	3 76	3 76	18.75 476	22 559	27.5 699	33.5 851
37/43" - 30.5" (940/1092 - 775 mm)	6,560 2,976	43 1,092	37 940	8.5 216	30.5 775	28.5 724	16.5 419	6 152	3 76	3 76	3 76	3 76	18.75 476	22 559	27.5 699	33.5 851
54" - 25.5" (1,372 - 648 mm)	8,910 4,041	54 1,372		8.5 216	25.5 648	25 635	16 406	8 203	3 76	3 76	3 76	3 76	22 558	31 788	40 1,016	
54" - 30.5" (1,372 - 775 mm)	8,810 3,996	54 1,371		8.5 216	30.5 775	25 635	16 406	8 203	3 76	3 76	3 76	3 76	22 558	31 788	40 1,016	

