

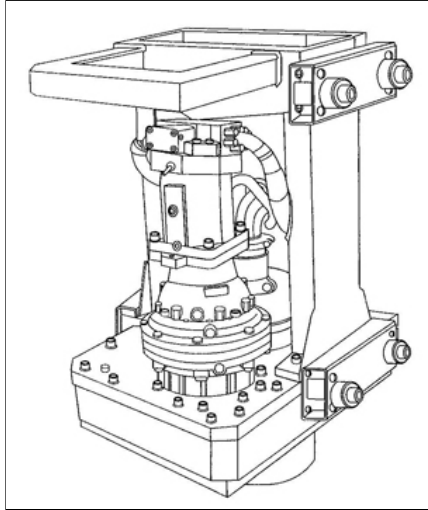

# J&M Model 3060 Top Drive Auger

The Worlds Largest Provider of  
Foundation Construction Equipment



Specifications		Standard	Metric
Low Speed High Torque	Torque	ft-lbs per 1000 psi	kgm per 69 bar
	Max Pressure	psi	bar
	Rotation Speed	0 rpm	
	Max Flow	0 gpm @ 0 gal / rev	0 lpm @ 0 lit / rev
	Max Horse Power	0 hp	0 kW
High Speed Low Torque	Torque	6,667 ft-lbs per 1000 psi	922 kgm per 69 bar
	Max Pressure	4,500 psi	310 bar
	Rotation Speed	60 rpm	
	Max Flow	168 gpm @ 2.24 gal / rev	636 lpm @ 8.48 lit / rev
	Max Horse Power	343 hp	255.78 kW
Crowd Force		35,000 lbs	15,876 kg
Suspendid Weight		3,000 lbs	1,361 kg
Length		38 in	97 cm
Width (Lead Section)		26 in	66 cm
Width (Overall)		in	cm
Height		52 in	132 cm
ID of Output Shaft		4 in	10 cm
ID of Rotary Joint		3 in	8 cm
API Adapters		API 3 inch, API 4 inch	
Lead Adapters		8 x 26, 8 x 32	

**WWW.APEVIBRO.COM**  
(800) 248-8498  
webmaster@apevibro.com



Specifications may vary due to site conditions, specific hammer conditions or product set up. Specifications may change without notice.  
Consult the factory for details on any specific product (800) 248-8498.

