

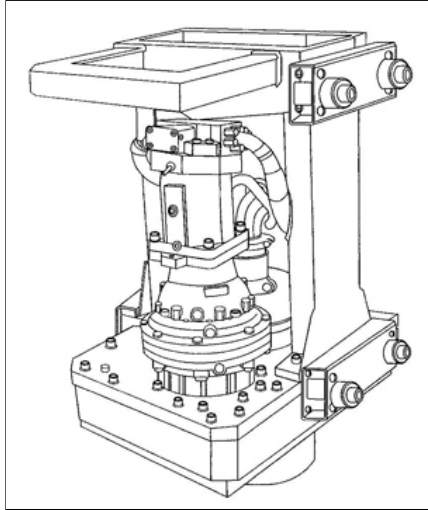

J&M Model 35AT Top Drive Auger

The Worlds Largest Provider of
Foundation Construction Equipment



Specifications		Standard	Metric
Low Speed High Torque	Torque	6,364 ft-lbs per 1000 psi	880 kgm per 69 bar
	Max Pressure	5,500 psi	379 bar
	Rotation Speed	50 rpm	
	Max Flow	90 gpm @ 1.8 gal / rev	341 lpm @ 6.81 lit / rev
	Max Horse Power	288 hp	214.76 kW
High Speed Low Torque	Torque	3,855 ft-lbs per 1000 psi	533 kgm per 69 bar
	Max Pressure	5,500 psi	379 bar
	Rotation Speed	75 rpm	
	Max Flow	90 gpm @ 1.2 gal / rev	341 lpm @ 4.54 lit / rev
	Max Horse Power	288 hp	214.76 kW
Crowd Force		35,000 lbs	15,876 kg
Suspendid Weight		35,000 lbs	15,876 kg
Length		38 in	97 cm
Width (Lead Section)		26 in	66 cm
Width (Overall)		in	cm
Height		52 in	132 cm
ID of Output Shaft		in	cm
ID of Rotary Joint		in	cm
API Adapters		API 3 inch, API 4 inch	
Lead Adapters		8 x 26, 8 x 32	

WWW.APEVIBRO.COM
(800) 248-8498
webmaster@apevibro.com



Specifications may vary due to site conditions, specific hammer conditions or product set up. Specifications may change without notice.
Consult the factory for details on any specific product (800) 248-8498.

