

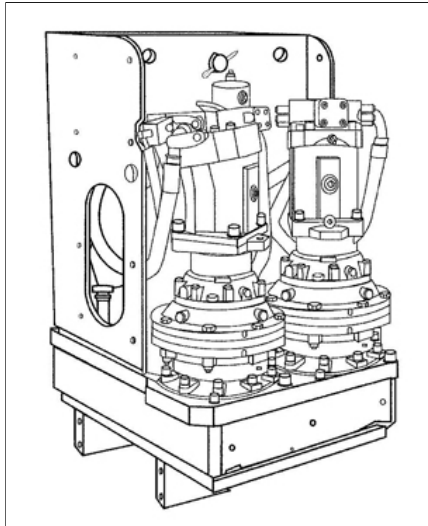

# J&M Model 5050 Top Drive Auger

The Worlds Largest Provider of  
Foundation Construction Equipment



| Specifications           |                 | Standard                   | Metric                    |
|--------------------------|-----------------|----------------------------|---------------------------|
| Low Speed<br>High Torque | Torque          | 11,111 ft-lbs per 1000 psi | 1,536 kgm per 69 bar      |
|                          | Max Pressure    | 4,500 psi                  | 310 bar                   |
|                          | Rotation Speed  | 30 rpm                     |                           |
|                          | Max Flow        | 85 gpm @ 3.5 gal / rev     | 322 lpm @ 13.25 lit / rev |
|                          | Max Horse Power | 273 hp                     | 203.58 kW                 |
| High Speed<br>Low Torque | Torque          | 5,556 ft-lbs per 1000 psi  | 768 kgm per 69 bar        |
|                          | Max Pressure    | 4,500 psi                  | 310 bar                   |
|                          | Rotation Speed  | 75 rpm                     |                           |
|                          | Max Flow        | 85 gpm @ 1.2 gal / rev     | 322 lpm @ 4.54 lit / rev  |
|                          | Max Horse Power | 223 hp                     | 166.29 kW                 |
| Crowd Force              |                 | 80,000 lbs                 | 36,287 kg                 |
| Suspendid Weight         |                 | 5,000 lbs                  | 2,268 kg                  |
| Length                   |                 | 38 in                      | 97 cm                     |
| Width (Lead Section)     |                 | 31 in                      | 77 cm                     |
| Width (Overall)          |                 | in                         | cm                        |
| Height                   |                 | 52 in                      | 132 cm                    |
| ID of Output Shaft       |                 | 3 in                       | 8 cm                      |
| ID of Rotary Joint       |                 | 3 in                       | 8 cm                      |
| API Adapters             |                 | API 3 inch, API 4 inch     |                           |
| Lead Adapters            |                 | 8 x 26, 8 x 32             |                           |

**WWW.APEVIBRO.COM**  
(800) 248-8498  
webmaster@apevibro.com



Specifications may vary due to site conditions, specific hammer conditions or product set up. Specifications may change without notice.  
Consult the factory for details on any specific product (800) 248-8498.

